

New

New applications
High ease of use



HAWA-Concepta 25/30/40/50 and HAWA-Folding Concepta 25

Turn – Fold – Slide in



Now with even more benefits:

HAWA-Concepta and HAWA-Folding Concepta

Two hardware concepts to revolutionize your room designs.

Create space and optimize rooms: virtually no other system is more capable than HAWA-Concepta and HAWA-Folding Concepta. They open up an especially versatile range of options through their well-designed and economical pivot, fold and slide-in technology. All the more so as user friendliness has increased further still, operating noise is lower than ever and the HAWA-Folding Concepta program is significantly larger than before. 3-door systems, for example, are now possible without middle walls. And the new black anodized profiles set new esthetic highlights. Be inspired!

See moving images at www.hawa.ch > HAWA-Productfinder



About Hawa AG: Always a guarantor of top quality

Ever since it was founded more than 50 years ago, Hawa AG has stood for outstanding workmanship, precise manufacturing and high quality. Of course, we have and always will bank on Switzerland as a production location in every regard. For our business philosophy remains founded on typical Swiss values such as safety, precision and excellent quality of service.

The concept

Furniture doors that pivot, fold and slide in to disappear into astonishingly small parking spaces: this is how to create multi-functional room solutions for the kitchen, home office, washer/dryer combinations, walk-in cabinets and many more applications in next to no time. Especially as the two systems, namely HAWA-Concepta and HAWA-Folding Concepta can be flexibly combined.



For doors that pivot and slide in sideways
HAWA-Concepta 25/30/40/50

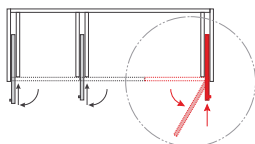

For doors that fold and slide in sideways
HAWA-Folding Concepta 25

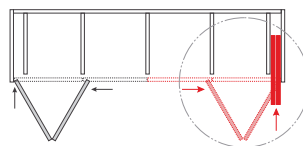

Combination 3-doors
HAWA-Concepta 25/30/40/50 and HAWA-Folding Concepta 25

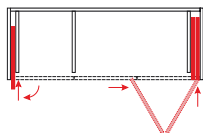

Additional combination options
HAWA-Concepta 25/30/40/50 and HAWA-Folding Concepta 25

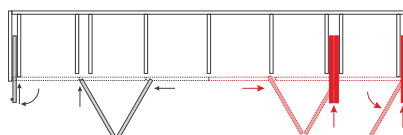

Flexible hardware for pivot/slide-in doors made of wood

HAWA-Concepta 25/30/40/50

The HAWA-Concepta supports variable space utilization in two ways: The HAWA-Concepta 25/30 version moves wooden doors up to 30 kg (66 lbs.) on quiet, rattle-proof guide rollers while the HAWA-Concepta 40/50 equipped with the smooth-running HAWA trolley slides doors weighing up to 50 kg (110 lbs.) into space-saving recesses. Either way, its ease of installation and impressive adaptability will open up completely new prospects for your cabinets, furniture fronts and walk-in storage solutions.

About the product

This hardware system offers a huge range of options yet needs only a small amount of space. This is because the doors parked to the side only take up a minimum amount of space inside the cabinet. The soft closing mechanism makes the system all the more user friendly. A range of fastening variants accommodate creative design ideas. And there's no way the HAWA-Concepta could possibly throw you off track: Installation requires no processing other than drilling holes for positioning and for the concealed hinges, as all components are screwed to the intermediate panel and always accessible from the front.



Generous, open wardrobe with unobstructed access thanks to slide-in doors.

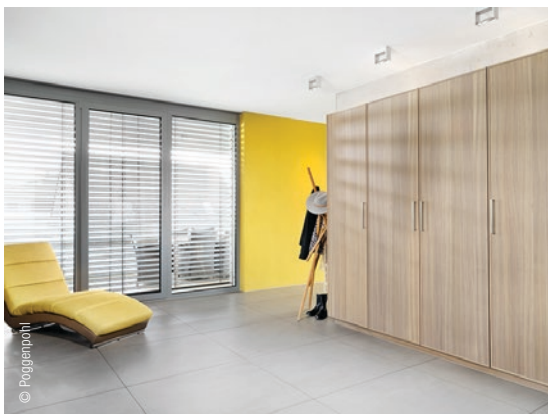

Neat closed front, elegantly integrated in the room.

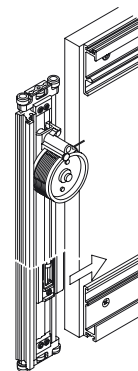
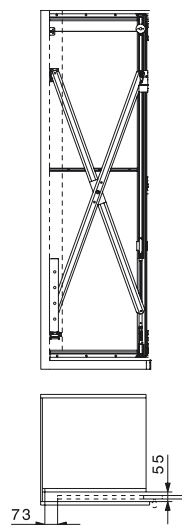

HAWA-Concepta 25/30.

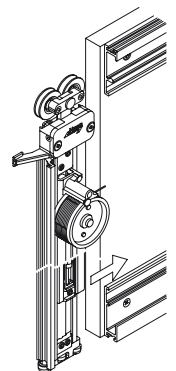

HAWA-Concepta 40/50.

At a glance

- Free access when the doors are slid fully into the pockets. No obstruction through protruding doors.
- Huge freedom of design, room-high, flush-fitting, walkable.
- Rattle-free guides and a soft door closing mechanism ensure smooth and quiet movement.
- Flexibly combined with HAWA-Folding Concepta 25.
- Easily tailored for different door dimensions.
- Identical sets for left hand and right hand doors.
- Minimum assembly time as all components are screwed onto the middle wall.

| Technical specifications HAWA-Concepta 25/30 | |
|---|---|
| Door weight | up to 25, 30 kg (55/66 lbs.) |
| Door width 25 | 300–750 mm (11 ¹³ / ₁₆ " – 2'5 ¹⁷ / ₃₂ " |
| Door width 30 | 300–900 mm (11 ¹³ / ₁₆ " – 2'11 ⁷ / ₁₆ " |
| Door thickness wood | 19–50 mm (³ / ₄ " – 1 ³¹ / ₃₂ " |
| Door height 25 | 1250–1850 mm (4'1 ⁷ / ₃₂ " – 6'0 ²⁷ / ₃₂ " |
| Door height 30 | 1851–2300 mm (6'0 ⁷ / ₈ " – 7'6 ⁹ / ₁₆ " |

| HAWA-Concepta 40/50 | |
|---------------------|---|
| Door weight | up to 40, 50 kg (88/110 lbs.) |
| Door width | 300–900 mm (11 ¹³ / ₁₆ " – 2'11 ⁷ / ₁₆ " |
| Door thickness | 19–50 mm (³ / ₄ " – 1 ³¹ / ₃₂ " |
| Door height 40 | 1851–2500 mm (6'0 ⁷ / ₈ " – 8'2 ⁷ / ₁₆ " |
| Door height 50 | 2301–2850 mm (7'6 ¹⁹ / ₃₂ " – 9'4 ⁷ / ₃₂ " |

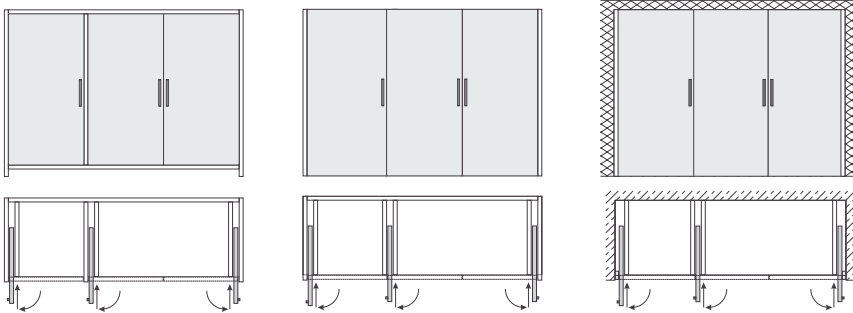

Inlaying doors.

Doors closing against base and top section.

Doors in wall recess.

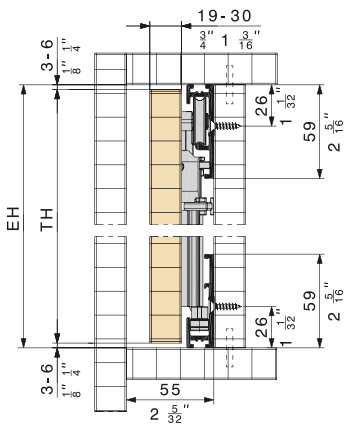

HAWA-Concepta 25/30.

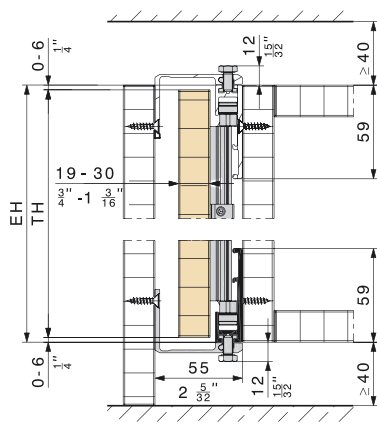

HAWA-Concepta 25/30 with Connector 55 mm (2³/₁₆”).

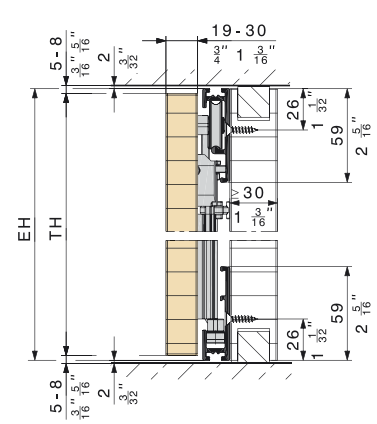

HAWA-Concepta 40/50.

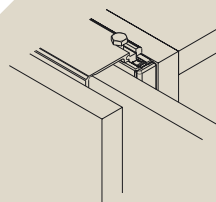

Connector 55 mm (2³/₁₆”):
Recess for a pivot/slide-in door.

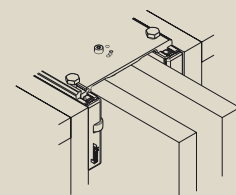

Connector 110 mm (4¹¹/₃₂”):
Recess for two pivot/slide-in doors.

Innovative hardware for wooden bi-folding sliding doors
that slide in from the side

HAWA-Folding Concepta 25

The future-oriented HAWA-Folding Concepta 25 puts on a great show as an impressive quick-change artist. It makes complete cabinet fronts of up to 2800 mm (9'2 1/4») in width – even without a center section – disappear flush with the outer face with a simple twist. The future of creative application designs is literally wide open: from an office recess in the spare bedroom to a utility room in the bathroom or a kitchen in the living room, the freedom of design is virtually boundless.

About the product

The HAWA-Folding Concepta 25 folds two doors and slides them into the side. This makes the system all the more spatially economic: the slide-in loss is a mere 73 mm (2 7/8»), the recess width only 110 mm (4 11/32»), and you even gain more freedom of movement in the room as the doors are parked away flush inside the cabinet body or recess when the front is open. You can count on these advantages in every situation: from the simplest cabinet designs with optional base profile and overlaying cabinet doors to room-high solutions without a furniture base to walk-in cabinets with continuous floors and cabinet fronts stretching from work surface to ceiling. Especially pleasing is that the front within a cabinet or kitchen front is always flush – and that also applies to combinations with HAWA-Concepta 25/30/40/50 or a pivot door. The HAWA-Folding Concepta 25 is wonderfully discreet both acoustically and visually thanks to rattle-proof guides and the new black anodized profiles.



From home to office and back. It couldn't be easier.

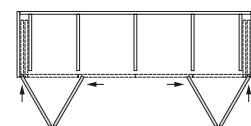
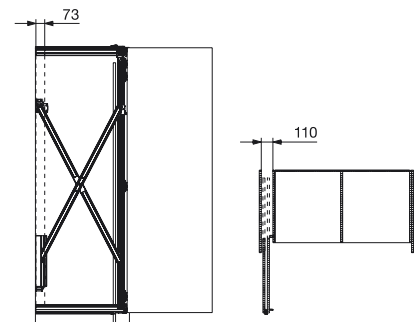

Double system.

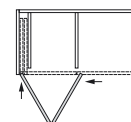

Left-hand installation.

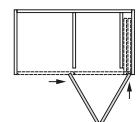

Right-hand installation.

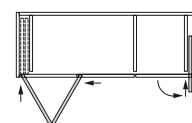

Left-hand installation.

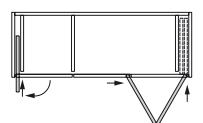

Right-hand installation.



HAWA-Folding Concepta 25 installed in a wall recess.

At a glance

- The entire cabinet front folds and slides in with a single hand movement.
- Reserved elegance inside and outside thanks to black anodized profiles.
- The combination with HAWA-Concepta enables wardrobes and cabinets with 2, 3 and 4 doors. Without middle walls.
- Easily tailored for different door dimensions.
- Great freedom of design: flush-fitting, room-high, walkable.
- Low slide-in loss of 73 mm ($2\frac{7}{8}$ ") in the cabinet depth.
- Rattle-proof guides for especially smooth and harmonious movement.

Technical Specifications HAWA-Folding Concepta 25

| | |
|----------------|---|
| Door weight | 25 kg (55 lbs.) (50 kg (110 lbs.) per door pair) |
| Door width | 300–700 mm ($11\frac{13}{16}$ "– $2'3\frac{9}{16}$ ") |
| Door thickness | 19–26 mm ($\frac{3}{4}$ "– $1\frac{1}{32}$ ") |
| Door height | 1250–2600 mm ($4'1\frac{7}{32}$ "– $8'6\frac{3}{8}$ ") |

Overlying cabinet front with base profile.

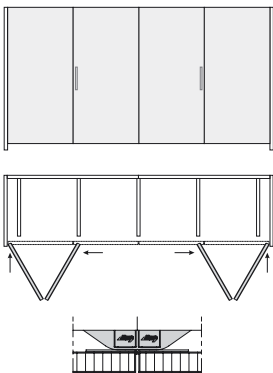

Recess cover without a cabinet base.

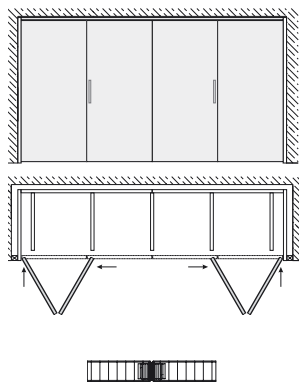

Semi height variant from the worktop.

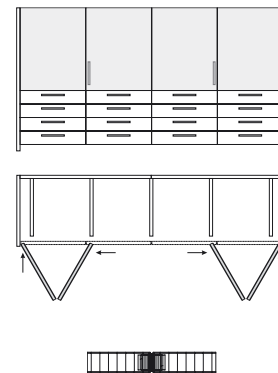

Door centring with leading ramp.

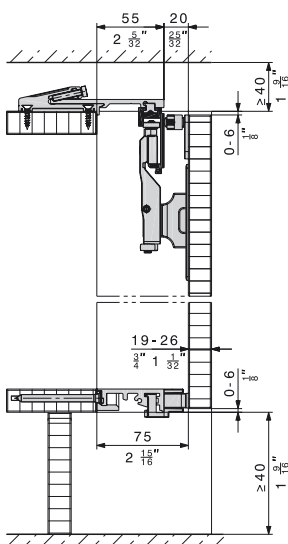

Door centring with magnetic centring elements.

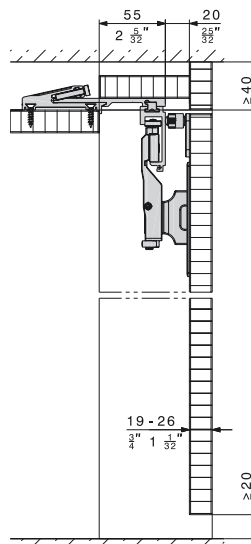

Door centring with magnetic centring elements.

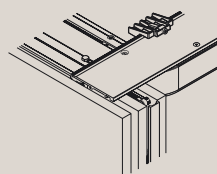
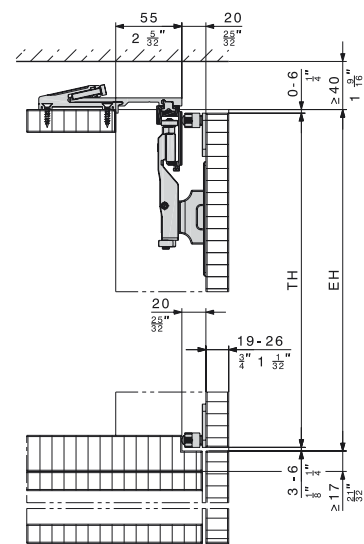

Component of the HAWA-Folding Concepta 25 set: well-thought-out connection profiles for cabinet body and sides ease the installation of overlying cabinet doors.

Available from specialist dealers

Further information:

Hawa Sliding Solutions AG
8932 Mettmenstetten
Switzerland
Tel. +41 44 787 17 17
Fax +41 44 787 17 18
www.hawa.com

