

New



Automated hardware system for flush-front folding sliding shutters

HAWA-Frontego 30/matic



Patent pending

Convenient folding sliding shutters are very flexible

HAWA-Frontego 30/matic

Architects and building owners can unfold their creativity with HAWA-Frontego 30/matic. After all, this fully automatic hardware system for flush-front folding sliding shutters weighing up to 30 kg (66 lbs.) per panel opens up new possibilities for large-surface facade designs – for commercial buildings and hotels as well as private homes and apartment blocks. All the more so as the system's convenience is strikingly apparent even before it is taken into operation. The HAWA-Frontego 30/matic for 2, 4 and 6-panel systems can be fitted to the ceiling, wall or lintel from the inside and from the outside; customised designs, pre-assembly and retro-fitting are all possible. Whilst these advantages are clearly visible, the technology behind them is not: the drive unit and control system are completely integrated to save even more space.

About the product

So gentle and yet so tough: that is how flexible the HAWA-Frontego 30/matic is in everyday use. Users will be impressed by its impeccable manners. An innovative drive unit with a brushless electric motor and high-quality gear system enable gentle acceleration and deceleration, and smooth running properties coupled with low energy consumption. But on the outside it is as tough as can be: unfaltering and undeterred, it braves wind and weather, acid rain, salt spray and other corrosion factors. And it fulfils the requirements of DIN EN standards so well that it can be recommended without hesitation for use in areas close to the coast and swimming pools, as well as in areas with high levels of air pollution.



Setting flexible accents of design: the striking look of HAWA-Frontego 30/matic.

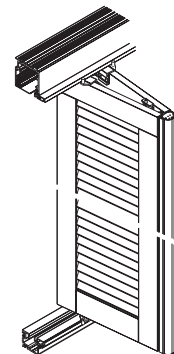

Whipping up a storm of enthusiasm: wind resistance

Even strong winds cannot ruffle the HAWA-Frontego 30/matic: the hardware is always steadfast thanks to a slightly open folding packet and integrated wind supports.



Speciality of the house: the right solution for every construction situation

Buildings are nearly as individual as the people who design them. A good thing that the HAWA-Frontego 30/matic can adapt perfectly to different architectural circumstances. Here are some of the main installation methods:

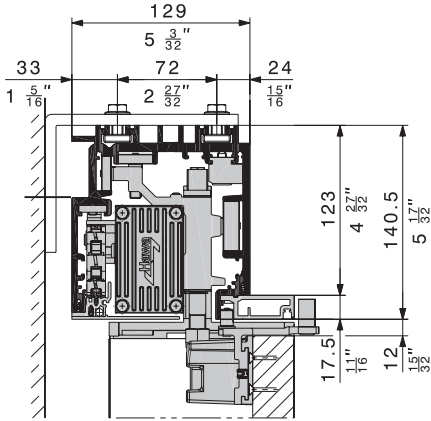

Top track:
Wall mounting with brackets and hammer head bolts provided by others.

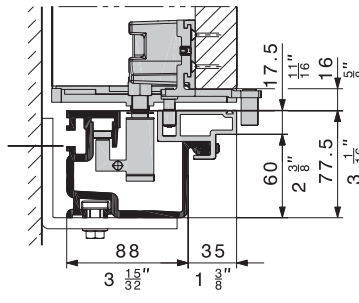

Guide rail:
Wall mounting with brackets and hammer head bolts provided by others.

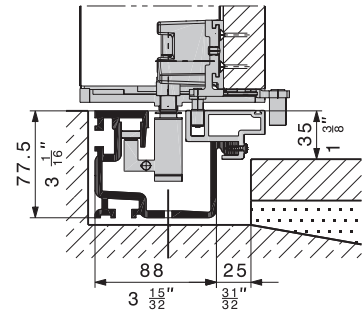

Guide rail:
Floor mounting with anchors, fixed floor plate.

A suitable design for every application

Flexibility included: although the number of shutters per system is limited to six panels, or three pairs, the option to design left or right hand installations allows for any combination of symmetrical and asymmetrical systems. Whereby every subsystem can be designed with a different folding sliding shutter width.

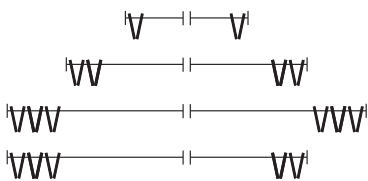

The folding packet stands to one side, slightly open at 90° to the sliding axis. Folding packet guideline width:
2-panel: 180 mm, 4-panel: 410 mm, 6-panel: 640 mm.

Made to measure: thanks to screen profiles, double hinges and strap hinges

Customise the hardware to suit your needs: use screen profiles to optimise privacy and shading. Together with the double hinge, the two-sided screen profile affords the greatest possible crush protection for walk-in systems. Strap hinges and light screen profiles are an attractive economic alternative for non-walk-in systems.

Walk-in system

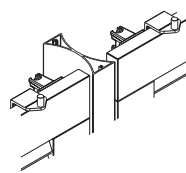

Protective trim on both sides.

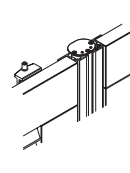

Double hinge.

Non-walk-in system

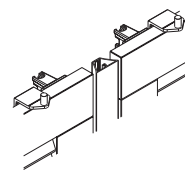

Light screen profile.

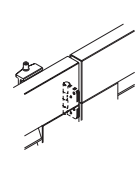

Strap hinge.

At a glance

- High resistance to wind loads (certified for Class 6, tested for Class 8), durability (20,000 cycles, tested for Class 3).
- Protection and safety measures on the basis of DIN EN 12453.
- Suitable for coastal areas thanks to high corrosion resistance; materials and coatings tested during a 1,000-hour salt spray test as per DIN EN 9227.
- Folding sliding shutters form a flush front when closed.
- Designs: 2, 4 or 6-panels, left or right hand, symmetrical and asymmetrical designs freely combinable.
- Screened areas of up to 12 m² for 6-panel installations with a shutter height of 3200 mm/shutter width of 600 mm.
- Folding sliding shutters can be locked top and bottom in any position.
- Developed in accordance with DIN EN 13659.

Technical specifications

Max. shutter weight	30 kg (66 lbs.)
Shutter width	300–600 mm (11 ¹³ / ₁₆ "–1'11 ⁵ / ₈ "
Shutter height	700–3200 mm (2'3 ⁹ / ₁₆ "–10'6"
Shutter thickness	28–32 mm (1 ¹ / ₈ "–1 ⁹ / ₃₂ "
Designs	2/4/6 panels

Technical details drive unit

Power supply	100 VAC to 240 VAC 50/60 Hz
Protection rating	IP54
Average speed	55 mm/s
Operating temp.	–20°C to 60°C
Power cons. in standby mode	< 5 W
Drive unit CE tested	



Addressing and controlling the system

The systems are addressed same as rolling shutter systems and operated via commercially available sunblind switches. Push-buttons are available on request for walk-in systems.

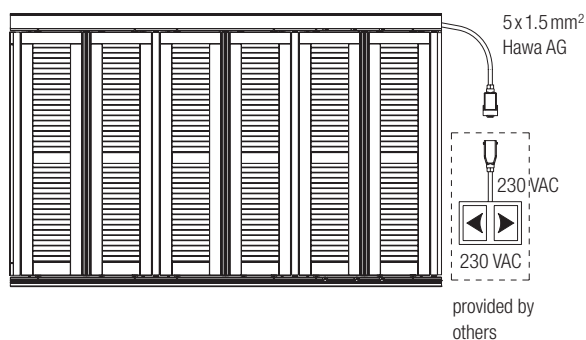

Putting safety and security up front

No worry lines with the HAWA-Frontego 30/matic: the system stops and reverses automatically when it encounters an obstacle. The robust design is also an effective burglar deterrent, especially as the shutters are locked top and bottom in any position. And closed automatically means bolted for the HAWA-Frontego 30/matic.

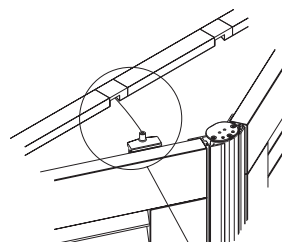



Fascinating interaction between light and surface.
And folding sliding shutters that are locked in every
position: HAWA-Frontego 30/matic.



All is flush: an impressively consistent front.

Available from authorised installers

Further information:

Hawa AG
8932 Mettmenstetten
Switzerland
Tel. +41 44 767 91 91
Fax +41 44 767 91 78
www.hawa.ch

