

# BAU

BUILDING BATIMENT



**EKU PORTA**  
Holz | Wood | Bois

## Schiebetechnik für Holztüren

Sliding technique for wooden doors

Technique de coulisse pour  
portes en bois

**EKU**   
Swiss Sliding Solutions



60/100 HM



60/100 HM



60/100 HMD



60/100 HMD



















60/100 HMT









EKU-PORTA 60/100 HMD

EKU-PORTA 60/100 HMT



**EKU PORTA®**

|   |   |  |              |
|---|---|--|--------------|
|    | <b>EKU-PORTA 45<br/>H</b>   |   | <b>6/7</b>   |
|    | <b>EKU-PORTA 60/100<br/>H</b>   |   | <b>8/9</b>   |
|    | <b>EKU-PORTA 60/100<br/>HC</b>  |   | <b>10/11</b> |
|    | <b>EKU-PORTA 60/100<br/>H/HC Synchro</b>  |  | <b>12/13</b> |
|    | <b>EKU-PORTA 60/100<br/>HM</b>  |   | <b>14/15</b> |
|    | <b>EKU-PORTA 60/100<br/>HMD</b>   |   | <b>16/17</b> |
|   | <b>EKU-PORTA 60/100<br/>HMT</b>   |  | <b>18/19</b> |
|  | <b>EKU-PORTA 100</b><br>4-Punkt-Führung/4 point guidance<br>Guidage à 4 points  |  | <b>25</b>    |
|  | <b>EKU-PORTA 60/100</b><br>Stapelung/Stacking system/<br>Rangement en parallèle |  | <b>26/27</b> |
|  | <b>EKU-PORTA 300<br/>H</b>  |  | <b>28/29</b> |
|  | <b>EKU-PORTA 600<br/>H</b>  |  | <b>30/31</b> |

|   |   |           |
|---|---|-----------|
| <b>Sonderzubehör EKU-PORTA 45/60/100</b>      |    | <b>22</b> |
| Special accessories<br>Accessoires spéciaux   |   |           |
| <b>Einzelteile EKU-PORTA 45</b>               |    | <b>23</b> |
| Components<br>Pièces détachées                |   |           |
| <b>Einzelteile EKU-PORTA 60/100</b>           |    | <b>24</b> |
| Components<br>Pièces détachées                |   |           |
| <b>Sonderzubehör EKU-PORTA 300</b>            |    | <b>32</b> |
| Special accessories<br>Accessoires spéciaux   |   |           |
| <b>Einzelteile EKU-PORTA 300</b>              |    | <b>32</b> |
| Components<br>Pièces détachées                |   |           |
| <b>Einzelteile EKU-PORTA 600</b>              |    | <b>33</b> |
| Components<br>Pièces détachées                |   |           |
| <b>EKU-Qualität</b>                           |    | <b>34</b> |
| EKU-Quality<br>EKU-Qualité                    |   |           |
| <b>Türgewichte</b>                            |   | <b>35</b> |
| Door weights<br>Poids de portes               |   |           |
| <b>Technische Daten</b>                       |  | <b>35</b> |
| Technical data<br>Caractéristiques techniques |   |           |

**EKU DÄMPFUNG**  
Soft close | Amortissement

|  |  |   |              |
|--|--|---|--------------|
|  | <b>EKU-DÄMPFUNG</b><br>EKU-Soft close<br>EKU-Amortissement |  | <b>20/21</b> |
|--|--|---|--------------|

|   |   |
|---|---|
| <p>System<br/>Système</p>                       | <p>Tragkraft pro Türe<br/>Carrying capacity<br/>per door<br/>Capacité de charge par porte</p> |
| <p><b>EKU PORTA®</b><br/>Holz   Wood   Bois</p> | <p><b>100 HMD</b></p> <p>Modell<br/>Model<br/>Modèle</p>                                      |





45/60/100 H



60/100 HC



60/100 HC



EKU-PORTA 60/100 H

EKU-PORTA 60/100 HC



60/100 HC



60/100 HC

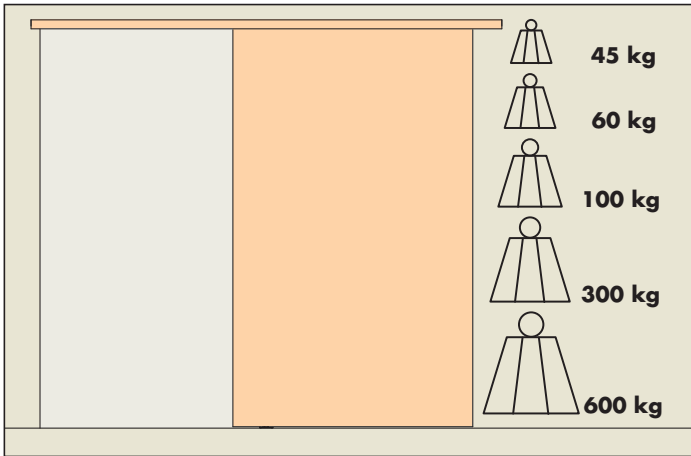

**5 Gewichtsklassen – 1 Beschlagssystem**

5 weight classes – 1 hardware system

5 catégories de poids – 1 système de ferrures

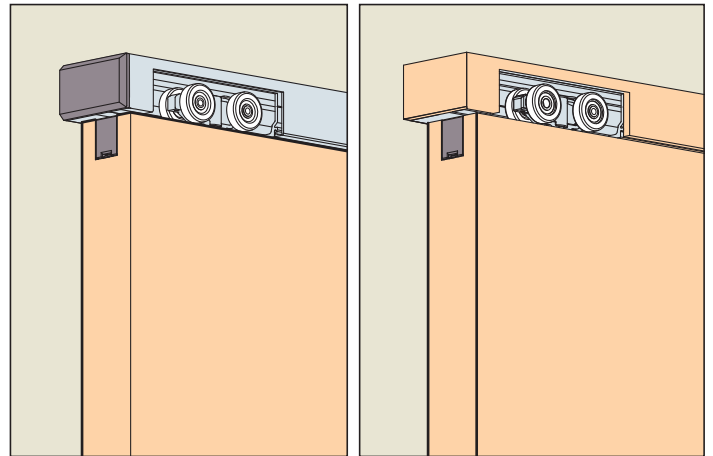

**Design-Laufschiene 31 mm hoch für Wandmontage mit Alu- oder Holz-Blende**

Design running track 31 mm high for wall mounting with aluminium or wooden panel

Rail de roulement design 31 mm haut pour montage mural avec cache bois ou alu

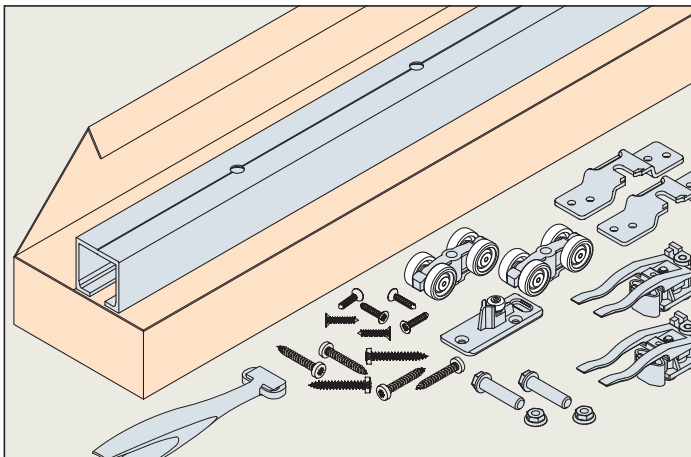

**Bestellung einfach und wirtschaftlich als Set**

Can be ordered as a set – Simple and economical

Commande en kit simple et économique

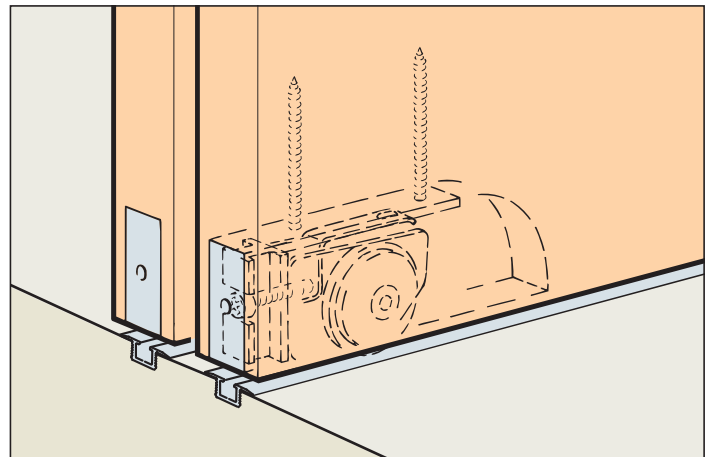

**Attraktives Zubehör – Synchro, Stapelung und 4-Punkt Führung**

Attractive accessories – Synchro, stacking system and 4-point guidance

Accessoire attractif – Synchro, parçage des portes en parallèle et guidage 4 points

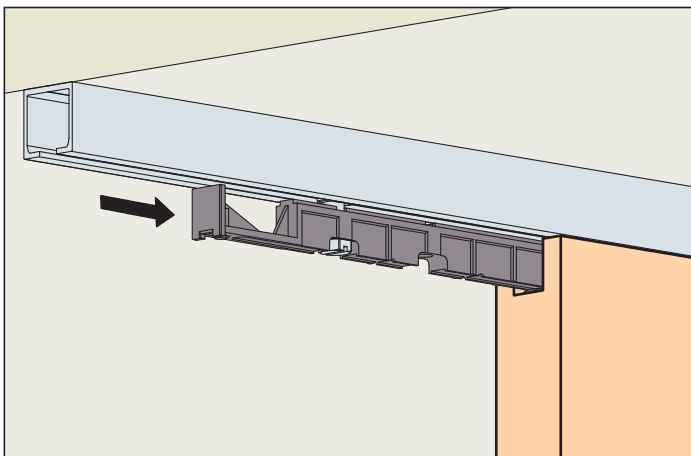

**Einfache und schnelle Türmontage ohne Werkzeug**

Door installation is quick and easy, without tools

Montage de porte simple et rapide sans outillage

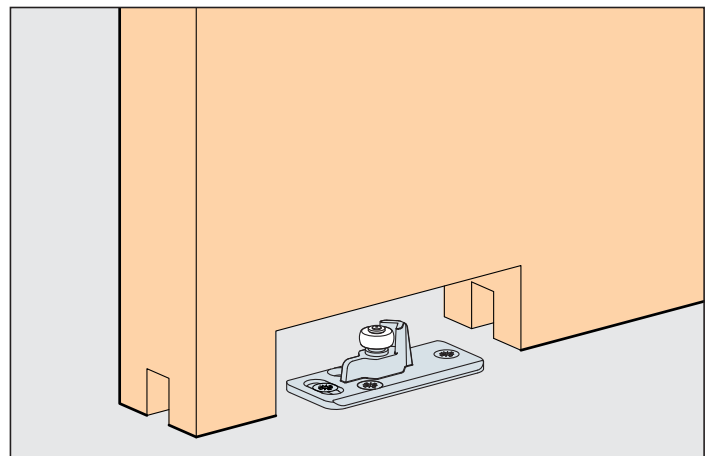

**Leichter und leiser Lauf – Laufwerke mit Präzisionskugellager – Bodenführung mit Rolle**

Gentle, quiet operation – Running gear with precision ball bearings – floor guide with roller

Course légère et silencieuse – Chariots avec roulement à billes de précision – Guidage au sol avec galet

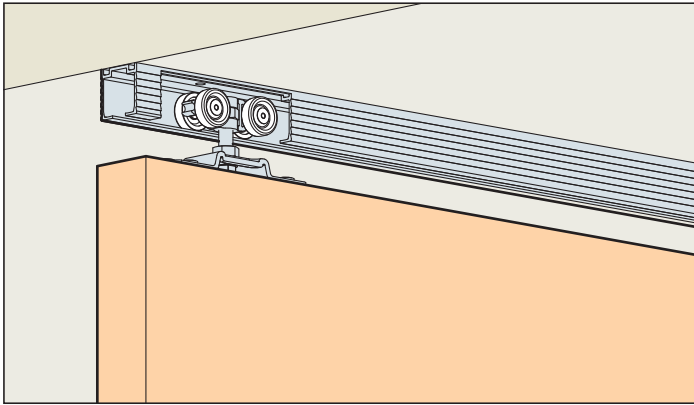

**System: Laufschiene für Decken- oder Wandmontage, für 1 Holztüre bis 45 kg.**

System: Running track for ceiling or wall mounting, for 1 wooden door up to 45 kg.

Système: Rail de roulement pour montage au plafond ou mural, pour 1 porte en bois jusqu'à 45 kg.

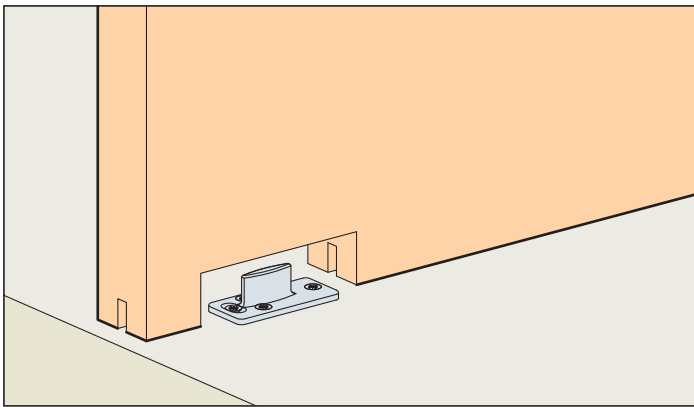



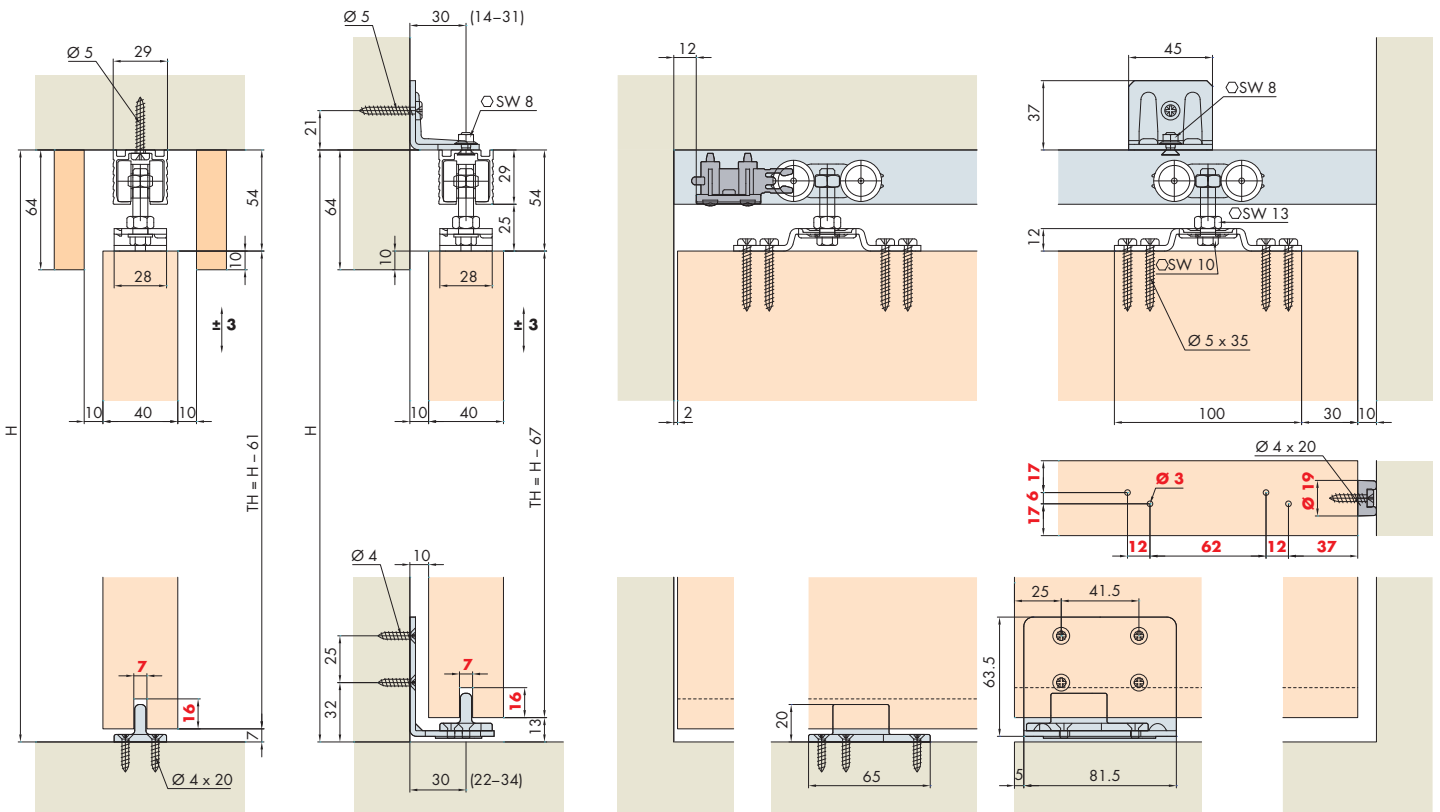

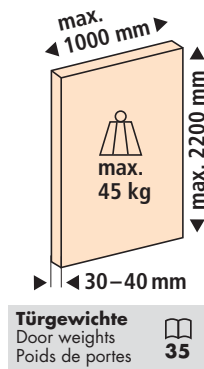

**Einbaubeispiele / Mounting examples / Exemples de montage**





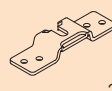

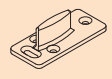

**Türbearbeitung = rote Zahlen / Door treatment = red numbers / Traitement de portes = numéros en rouge**

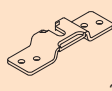

**Garnituren / Sets / Garnitures**

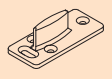
| 1 Türe / Door / Porte   |   | No. 057.3045.071   |    |
|---|---|--|----|
|  |    |  | 2x |
| 2x  | 2x  | 2x   |    |
|  |   |  |    |
| 1x  | 1x  |  |    |
|  |  |  |    |
| 1x  |   |  |    |

| 1 Türe / Door / Porte   |   | No. 057.3144.071  |    |
|---|---|---|----|
|  |  |  | 2x |
| 2x  | 2x  | 2x  |    |
|  |  |   |    |
| 1x  | 1x  |   |    |
|  |  |   |    |
| 1x  |   |   |    |

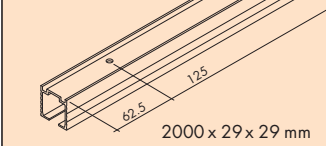
**Zubehör / Accessories / Accessoires**

**Einfachlaufschiene, Alu, gelocht**

Running track, aluminium, pre-drilled  
 Rail de roulement, en alu, perforé

Gr./Size

Art. No.

|         |              |
|---------|--------------|
| 1700 mm | 057.3037.170 |
| 2000 mm | 057.3037.200 |
| 2500 mm | 057.3037.250 |
| 6000 mm | 057.3037.600 |

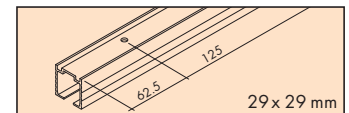

**Winkel-Set für Wandmontage, Stahl verzinkt (alle 500 mm)**

Angle-bracket set for wall mounting, zinc-plated steel (every 500 mm)  
 Lot d'équerres de fixation murale, en acier zingué (tous les 500 mm)

10x

057.3005.172

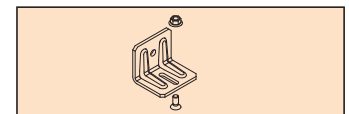

**Sonderzubehör / Special accessories / Accessoires spéciaux:** 22

**Einzelteile / Components / Pièces détachées:** 23

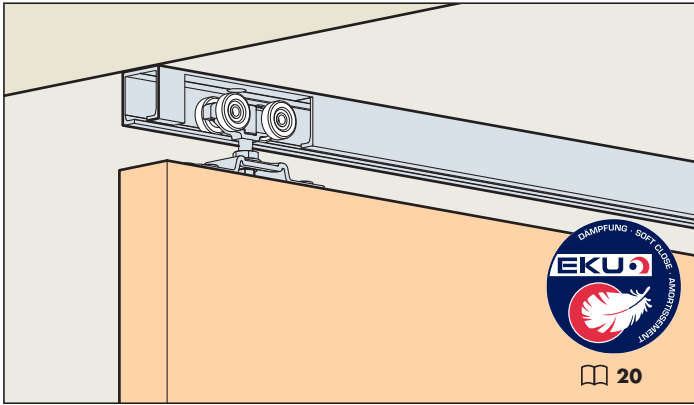

**System: Laufschiene für Decken- oder Wandmontage, für 1 Holztüre bis 60/100 kg.**

System: Running track for ceiling or wall mounting, for 1 wooden door up to 60/100 kg.

Système: Rail de roulement pour montage au plafond ou mural, pour 1 porte en bois jusqu'à 60/100 kg.

**Einbauvariante**

Mounting options

Variantes de montage

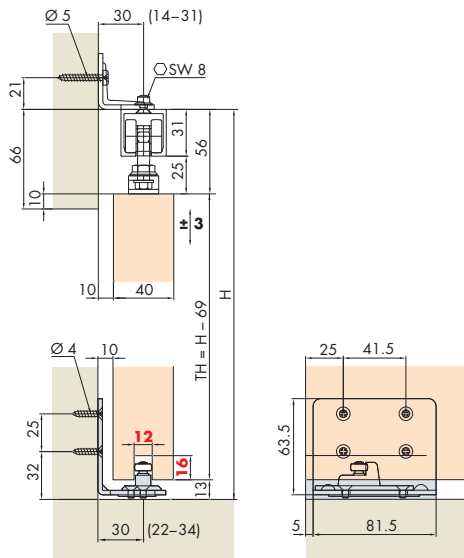
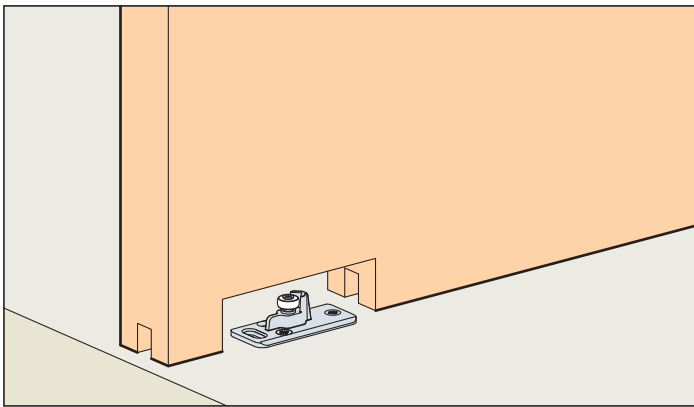

**Einbaubeispiele / Mounting examples / Exemples de montage**

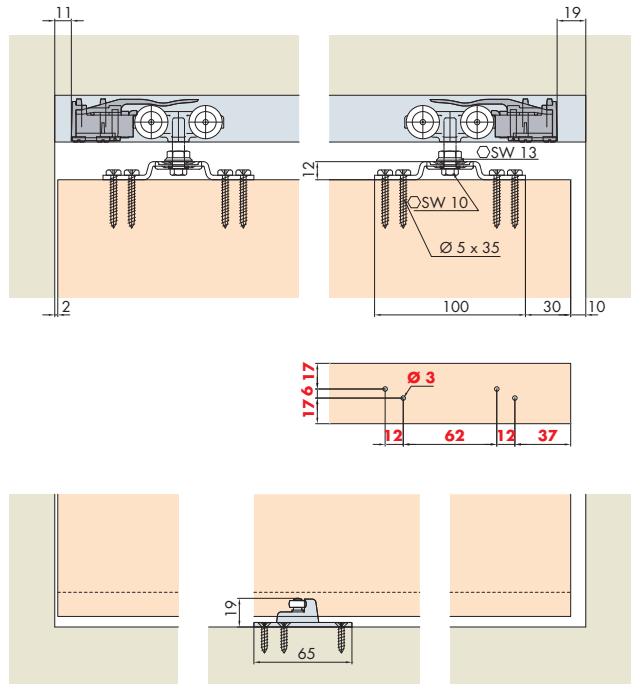
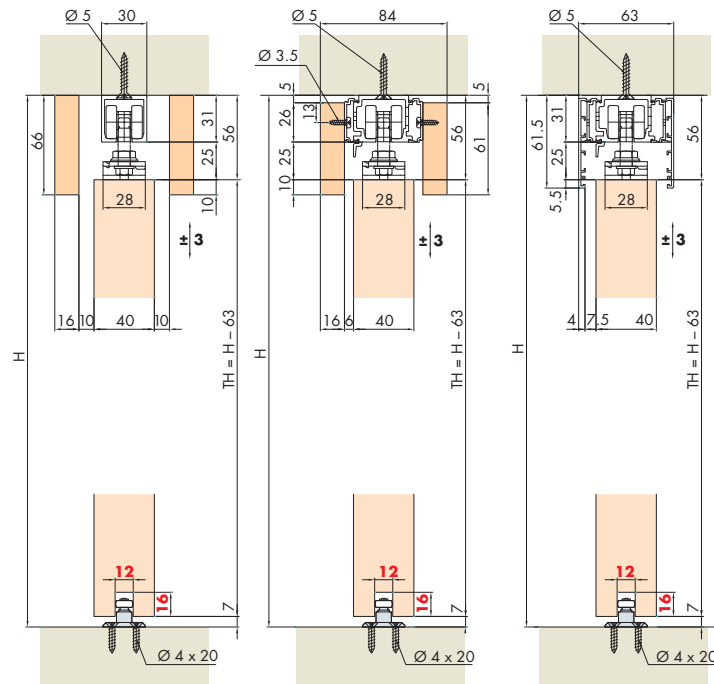



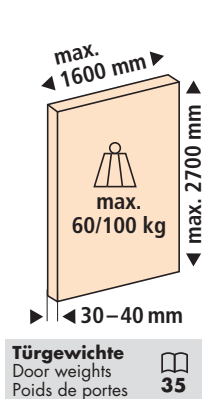

Garnituren / Sets / Garnitures

| EKU-PORTA 60/100  |   |
|-------------------|---|
| 1 Türe Door Porte | 60 No. 057.3138.071<br>100 No. 057.3139.071 |
| 2x                | 2x  |
| 1x                | 2x  |
| 2x                |   |

| EKU-PORTA 60/100                               |                  |
|--|------------------|
| 1 Türe Door Porte                              | No. 057.3140.071 |
| 2x   | 2x               |
| 1x   | 2x               |
| 2x   |                  |
| <p>Alu Aluminium<br/>Alu<br/>2000x30x31 mm</p> |                  |

| EKU-PORTA 100  |                  |
|--|------------------|
| 1 Türe Door Porte  | No. 057.3141.071 |
| 2x   | 2x               |
| 1x   | 2x               |
| 2x   | 1x               |
| <p>Alu eloxiert<br/>Aluminium anodized<br/>Alu anodisé<br/>2000x30x31 mm</p> |                  |

Zubehör / Accessories / Accessoires

**Einfachlaufschiene, Alu, gelocht**

Running track, aluminium, pre-drilled  
Rail de roulement, en alu, perforé

| Gr./Size | Art. No.     |
|----------|--------------|
| 1500 mm  | 057.3016.150 |
| 1700 mm  | 057.3016.170 |
| 2000 mm  | 057.3016.200 |
| 2500 mm  | 057.3016.250 |
| 6000 mm  | 057.3016.600 |

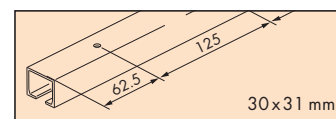

**Einfachlaufschiene, Alu eloxiert, gelocht**

Running track, aluminium anodized, pre-drilled  
Rail de roulement, en alu anodisé, perforé

|         |               |
|---------|---------------|
| 2000 mm | 057.3016.201  |
| 2500 mm | 057.3016.251  |
| 2500 mm | 057.3016.256* |
| 6000 mm | 057.3016.601  |

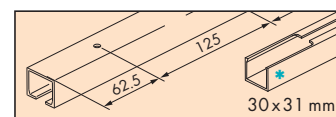

**Winkel-Set für Wandmontage, Stahl verzinkt (alle 500 mm)**

Angle-bracket set for wall mounting, zinc-plated steel (every 500 mm)  
Lot d'équerres de fixation murale, en acier zingué (tous les 500 mm)

|     |              |
|-----|--------------|
| 10x | 057.3005.172 |
|-----|--------------|

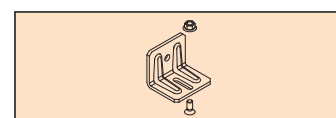

**Combi-Laufschiene, Alu, gelocht**

Combi running track, aluminium, pre-drilled  
Rail de roulement Combi, en alu, perforé

|         |              |
|---------|--------------|
| 1700 mm | 057.3048.170 |
| 2000 mm | 057.3048.200 |
| 2500 mm | 057.3048.250 |
| 3500 mm | 057.3048.350 |
| 6000 mm | 057.3048.600 |

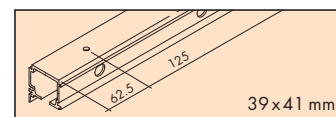

**Clip-Blende, Alu eloxiert, für Wandmontage**

Clip panel, aluminium anodized, for wall mounting  
Cache à clipser, en alu anodisé, montage mural

|         |              |
|---------|--------------|
| 2500 mm | 042.3004.250 |
| 3500 mm | 042.3004.350 |
| 6000 mm | 042.3004.600 |

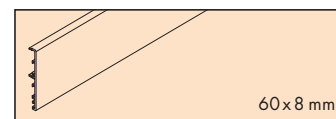

**Clip-Teil für Holz- und Alublende, Alu, gelocht (alle 500 mm)**

Clip component for wooden and aluminium panel, aluminium pre-drilled (every 500 mm)  
Clip pour cache en bois ou en alu, en alu, perforé (tous les 500 mm)

|              |
|--------------|
| 057.3117.001 |
|--------------|

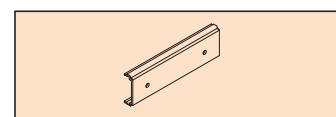

\*Montageöffnung und Abdeckkappe / Assembly opening and cover cap / L'ouverture de montage et cache: 21

Sonderzubehör / Special accessories / Accessoires spéciaux: 22

Einzelteile / Components / Pièces détachées: 24

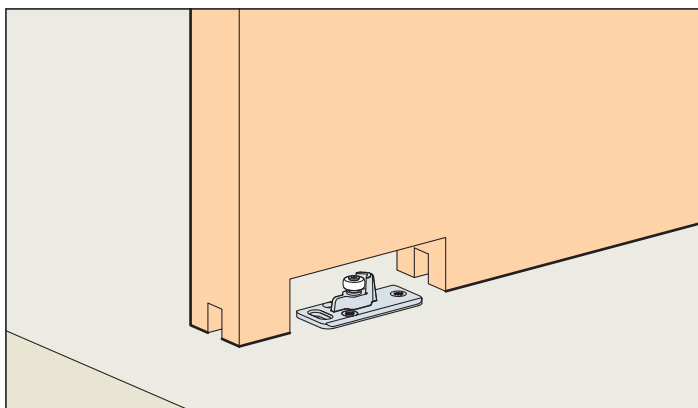
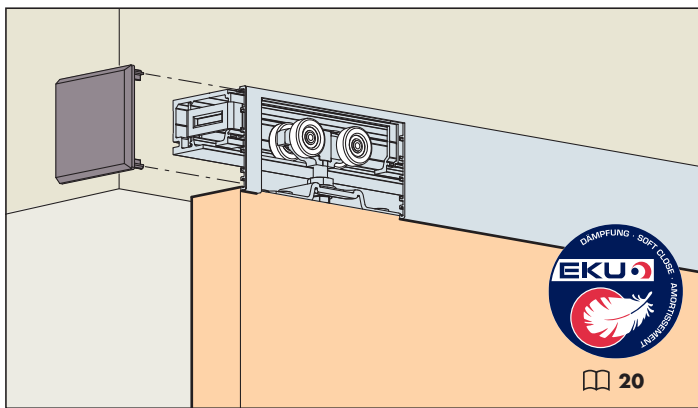

**System: Laufschiene für Wandmontage,  
für 1 Holztüre bis 60/100 kg.**

System: Running tracks for wall mounting,  
for 1 wooden door up to 60/100 kg.

Système: Rail de roulement pour montage mural,  
pour 1 porte en bois jusqu'à 60/100 kg.

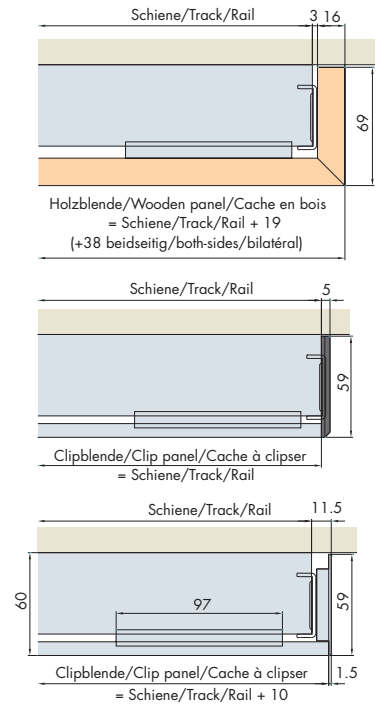

**Einbaubeispiele / Mounting examples / Exemples de montage**

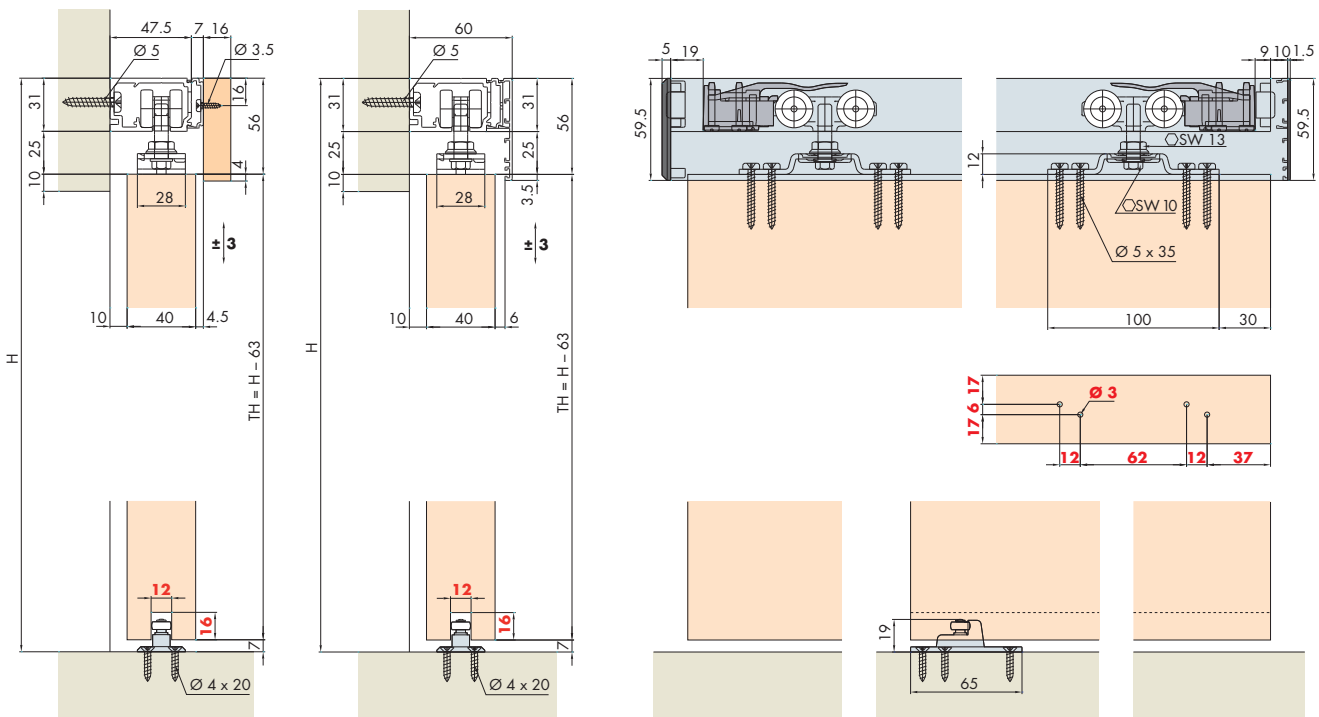

**Türbearbeitung = rote Zahlen / Door treatment = red numbers / Traitement de portes = numéros en rouge**

**Garnituren / Sets / Garnitures**

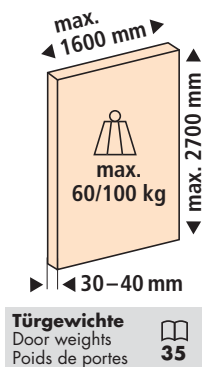

| EKU-PORTA 60/100  |   |
|-------------------|---|
| 1 Türe Door Porte | 60 No. 057.3138.071<br>100 No. 057.3139.071 |
| 2x                | 2x  |
| 1x                | 2x  |
| 2x                | 5x  |

| EKU-PORTA 60      |                  |
|-------------------|------------------|
| 1 Türe Door Porte | No. 057.3142.071 |
| 2x                | 2x               |
| 1x                | 2x               |
| 2x                | 5x               |
| 2000x47.5 x 31 mm |                  |

| EKU-PORTA 100     |                  |
|-------------------|------------------|
| 1 Türe Door Porte | No. 057.3143.071 |
| 2x                | 2x               |
| 2x                | 1x               |
| 1x                | 2x               |
| 1x                | 5x               |
| 2000x47.5 x 31 mm |                  |
| 2000x8 x 59.5 mm  |                  |

**Einbauvariante**  
Mounting options  
Variantes de montage

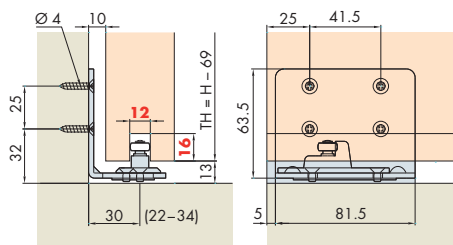

**Zubehör / Accessories / Accessoires**

**Einfachlaufschiene, Alu eloxiert, gelocht**

Running track, aluminium anodized, pre-drilled  
Rail de roulement, en alu anodisé, perforé

| Gr./Size | Art. No.     |
|----------|--------------|
| 2500 mm  | 057.3112.250 |
| 3500 mm  | 057.3112.350 |
| 6000 mm  | 057.3112.600 |

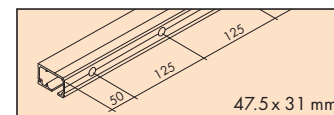

**Clip-Blende, Alu eloxiert, für Wandmontage**

Clip panel, aluminium anodized, for wall mounting  
Cache à clipser, en alu anodisé, montage mural

|         |              |
|---------|--------------|
| 2500 mm | 042.3004.250 |
| 3500 mm | 042.3004.350 |
| 6000 mm | 042.3004.600 |

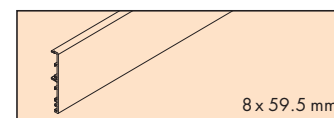

**Clip-Teil für Holz- und Alublende, Alu, gelocht (alle 500 mm)**

Clip component for wooden and aluminium panel, aluminium pre-drilled (every 500 mm)  
Clip pour cache en bois ou en alu, en alu, perforé (tous les 500 mm)

057.3117.001

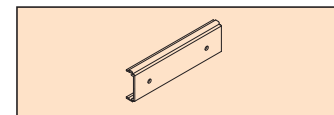

**Sicherungskammern für Holzblende**

Limiters for wooden panel  
Limiteur pour cache en bois

057.3126.071

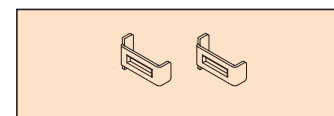

**Blendenendstück-Set, Alu eloxiert, inkl. Sicherungsklammer, für Alublende**

Panel end component set, aluminium anodized, incl. limiter, for aluminium panel  
Jeu d'extrémités de cache, en alu anodisé, avec limiteur, pour cache en alu

042.3028.076

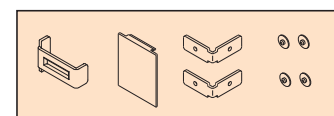

**Endkappen-Set, Kunststoff anthrazit, inkl. Sicherungskammern, für Alublende**

End cap set, plastic anthracite, incl. limiters, for aluminium panel  
Jeu d'embouts, plastique anthracite, avec limiteur, pour cache en alu

057.3132.072

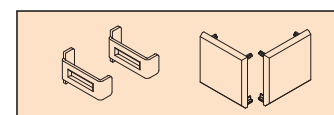

**Sonderzubehör / Special accessories / Accessoires spéciaux: ☐ 22**

**Einzelteile / Components / Pièces détachées: ☐ 24**

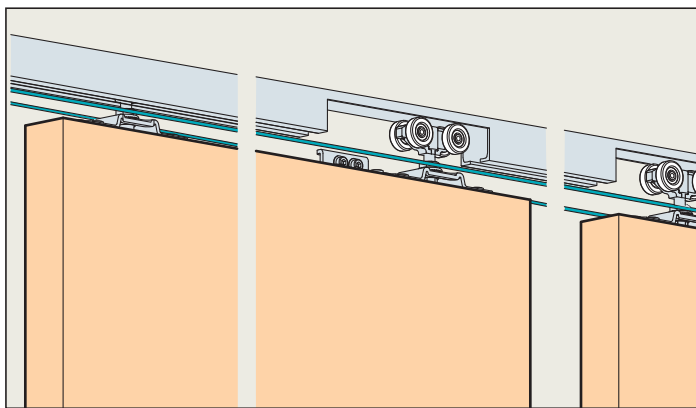

**Systemzusatz: Synchro für 2 synchronlaufende Holztüren mit Kevlarseil, zu EKU-PORTA 60/100 H/HC**

System addition: Synchro for 2 synchronized running wooden doors with kevlar rope, for EKU-PORTA 60/100 H/HC

Supplément de système: Synchro pour 2 portes en bois synchronisé avec câble kevlar, pour EKU-PORTA 60/100 H/HC

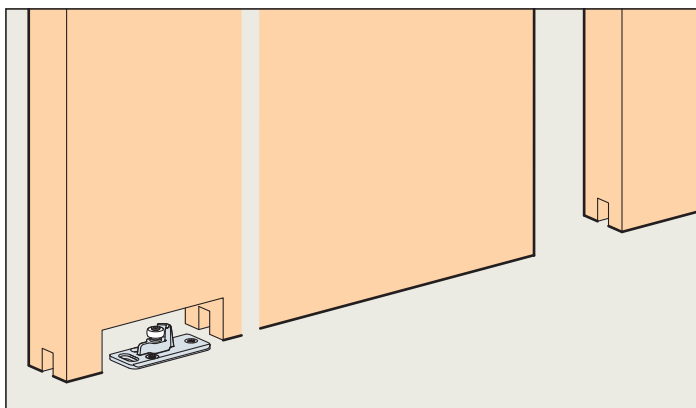

**Einbaubeispiele / Mounting examples / Exemples de montage**

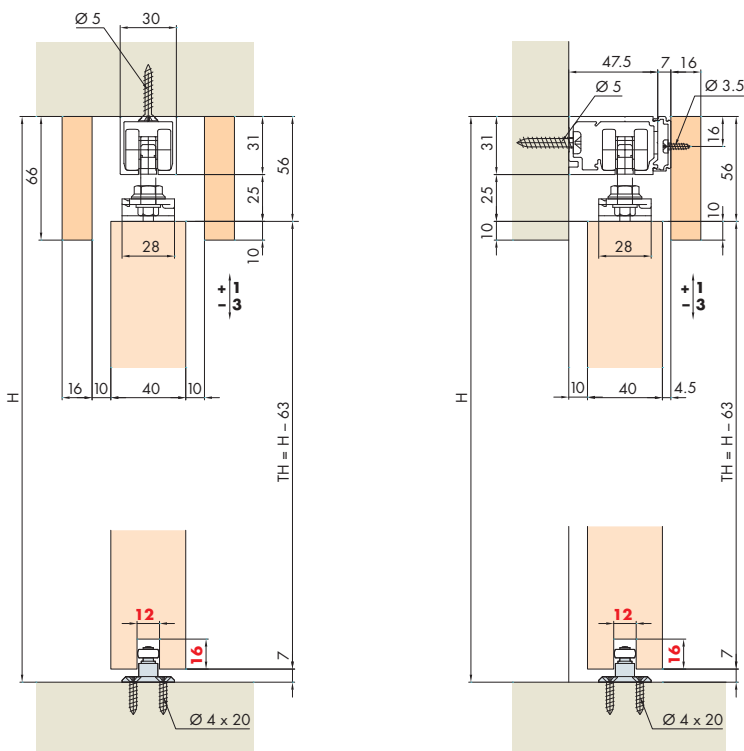

**Türbearbeitung = rote Zahlen / Door treatment = red numbers / Traitement de portes = numéros en rouge**

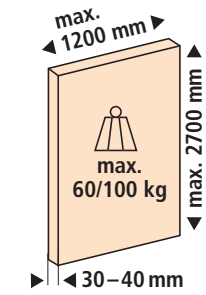

**Türgewichte**  
Door weights  
Poids de portes **35**

## Garnituren / Sets / Garnitures

| EKU-PORTA 60/100               |  |
|--------------------------------|--|
| <b>1</b> Türe<br>Door<br>Porte | <b>60 No. 057.3138.071</b><br><b>100 No. 057.3139.071</b>                              |
| 2x                             | 2x   |
| 1x                             | 2x   |
|                                | <b>Bitte 2 Garnituren bestellen</b><br>Please order 2 sets<br>A commander 2 garnitures |

| EKU-PORTA Synchro                 |                         |
|-----------------------------------|-------------------------|
| <b>2</b> Türen<br>Doors<br>Portes | <b>No. 042.3027.072</b> |
| 2x                                | 2x                      |
| 2x                                | 2x                      |
| 1x                                |                         |

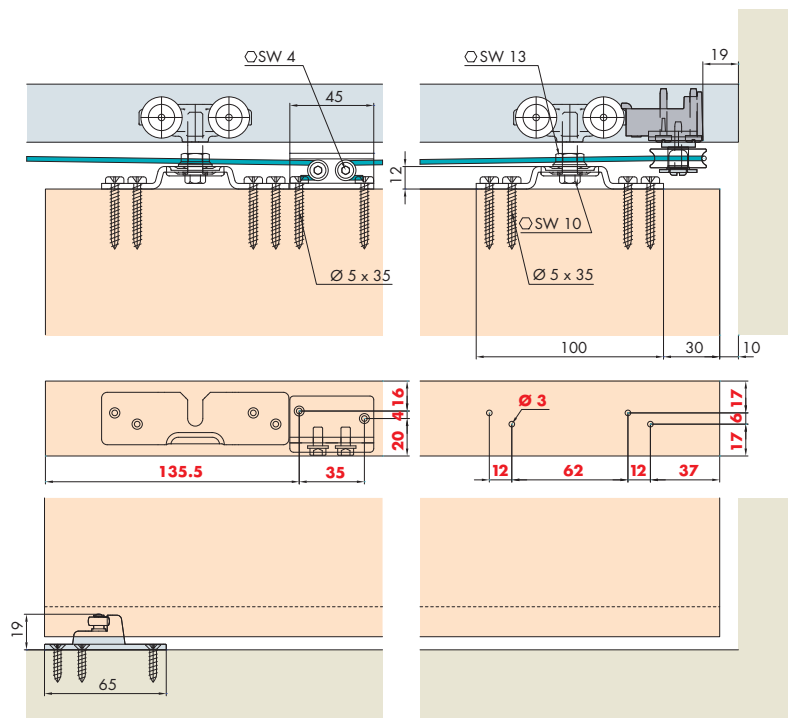
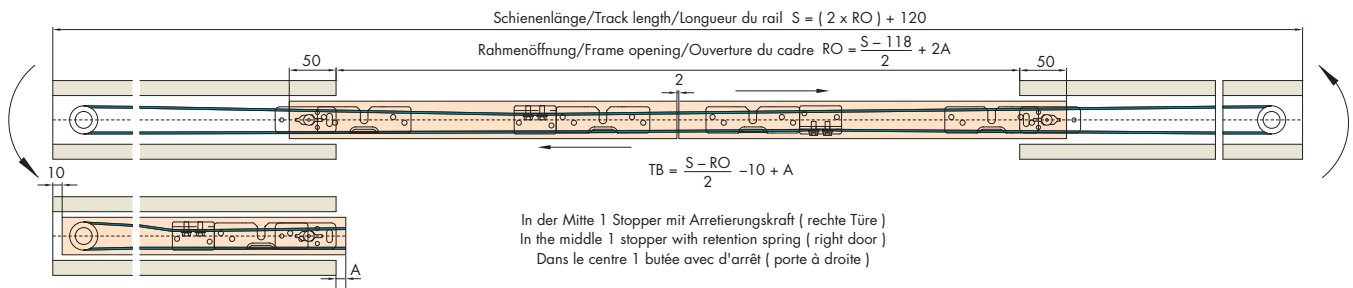



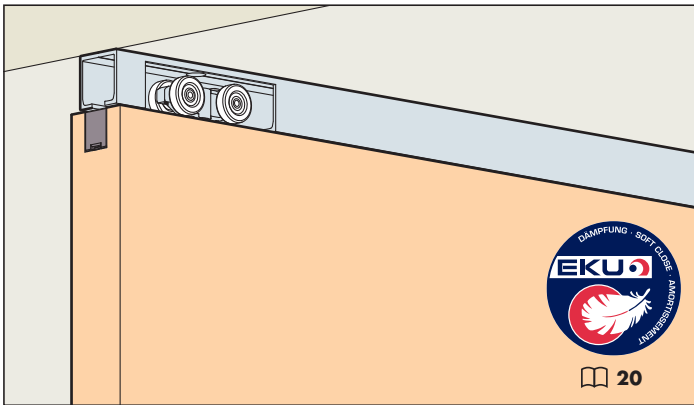

**System: Laufschiene für Deckenmontage, Einbauhöhe 31 mm, einsetzbar aufgesetzt oder deckenbündig, für 1 Holztüre bis 60/100 kg.**

System: Running track for ceiling mounting, installation height 31 mm, surface mounted or flush with the ceiling, for 1 wooden door up to 60/100 kg.

Système: Rail de roulement pour montage au plafond, hauteur d'installation 31 mm, montage en applique ou affleurant avec le plafond, pour 1 porte en bois jusqu'à 60/100 kg.

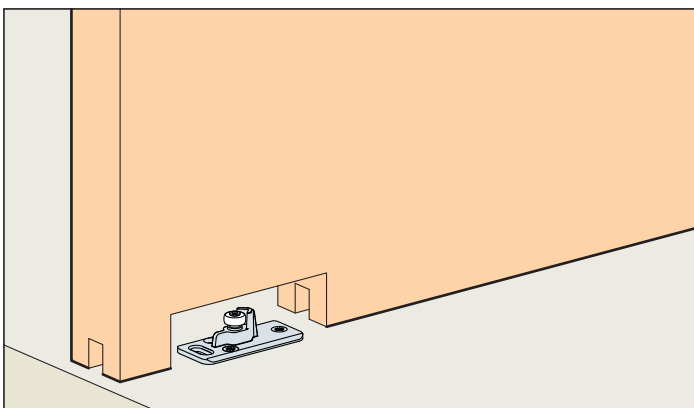

**Einbaubeispiele / Mounting examples / Exemples de montage**

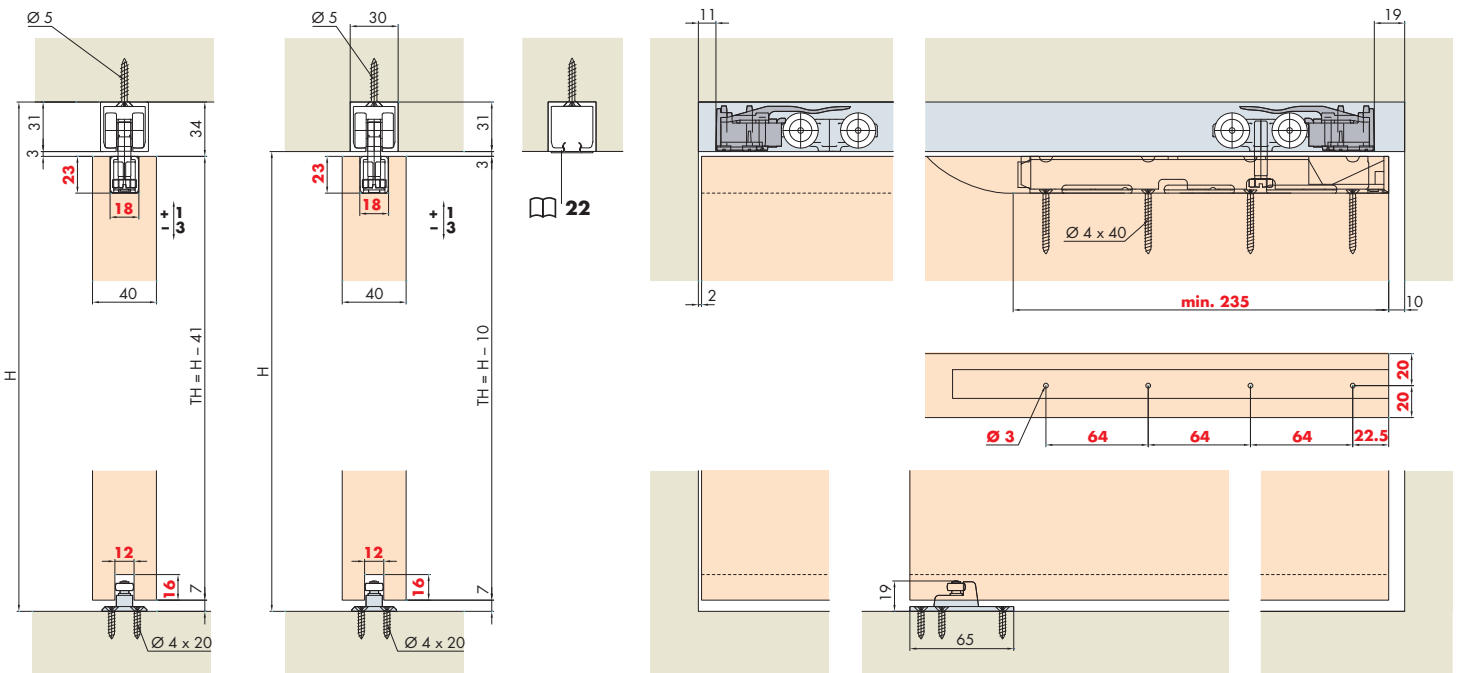

**Garnituren / Sets / Garnitures**

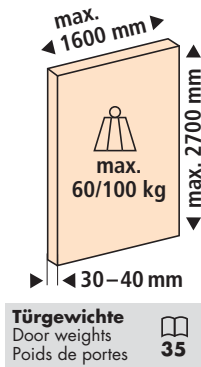

| EKU-PORTA 60/100  |   |
|-------------------|---|
| 1 Türe Door Porte | 60 No. 057.3133.072<br>100 No. 057.3133.071 |
| 2x                | 2x  |
| 2x                | 2x  |
| 1x                |   |

| EKU-PORTA 60/100                               |                  |
|--|------------------|
| 1 Türe Door Porte                              | No. 057.3134.071 |
| 2x   | 2x               |
| 2x   | 2x               |
| 1x   |                  |
| <p>Alu Aluminium<br/>Alu<br/>2000x30x31 mm</p> |                  |

| EKU-PORTA 100  |                  |
|--|------------------|
| 1 Türe Door Porte  | No. 057.3135.071 |
| 2x   | 2x               |
| 2x   | 2x               |
| 1x   |                  |
| <p>Alu eloxiert<br/>Aluminium anodized<br/>Alu anodisé<br/>2000x30x31 mm</p> |                  |

**Zubehör / Accessories / Accessoires**

**Einfachlaufschiene, Alu, gelocht**

Running track, aluminium, pre-drilled  
Rail de roulement, en alu, perforé

Gr./Size Art. No.

|         |              |
|---------|--------------|
| 1500 mm | 057.3016.150 |
| 1700 mm | 057.3016.170 |
| 2000 mm | 057.3016.200 |
| 2500 mm | 057.3016.250 |
| 6000 mm | 057.3016.600 |

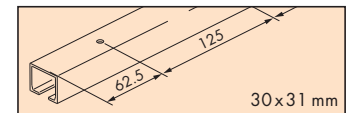

**Einfachlaufschiene, Alu eloxiert, gelocht**

Running track, aluminium anodized, pre-drilled  
Rail de roulement, en alu anodisé, perforé

|         |               |
|---------|---------------|
| 2000 mm | 057.3016.201  |
| 2500 mm | 057.3016.251  |
| 2500 mm | 057.3016.256* |
| 6000 mm | 057.3016.601  |

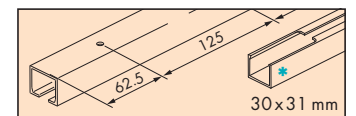

\*Montageöffnung und Abdeckkappe / Assembly opening and cover cap / L'ouverture de montage et cache: 21

Sonderzubehör / Special accessories / Accessoires spéciaux: 22

Einzelteile / Components / Pièces détachées: 24

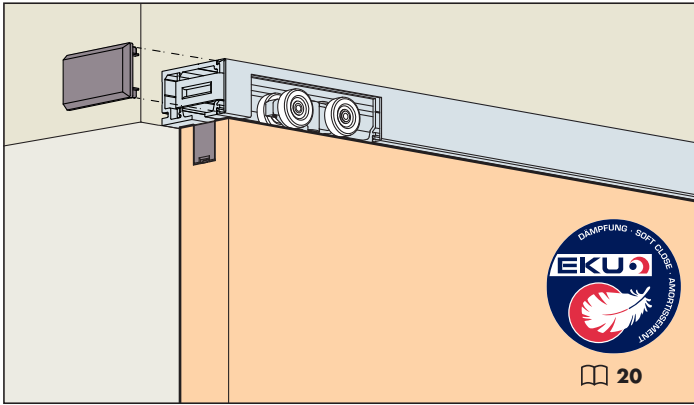

**System: Designlaufschiene für Wandmontage, Einbauhöhe 31mm, für 1 Holztüre bis 60/100 kg.**

System: Design running track for wall mounting, installation height 31 mm, for 1 wooden door up to 60/100 kg.

Système: Rail de roulement design pour montage mural, hauteur d'installation 31 mm, pour 1 porte en bois jusqu'à 60/100 kg.

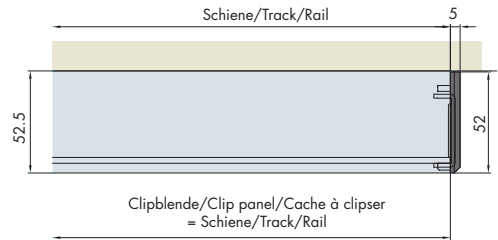
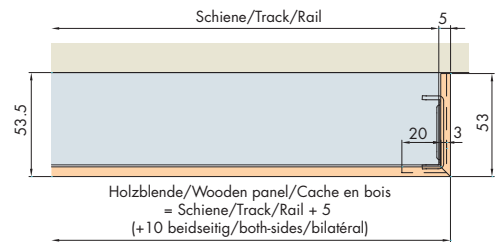
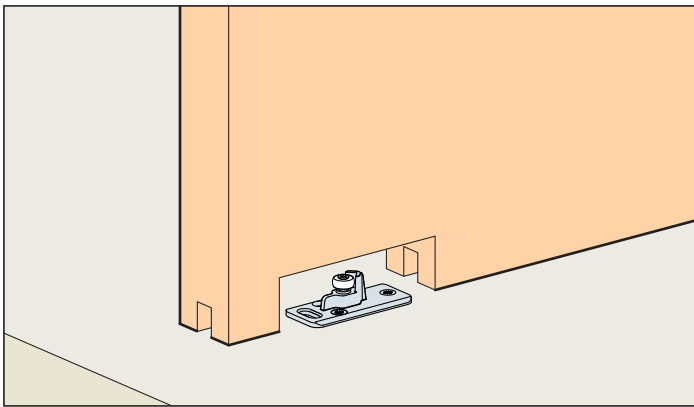

**Einbaubeispiele / Mounting examples / Exemples de montage**

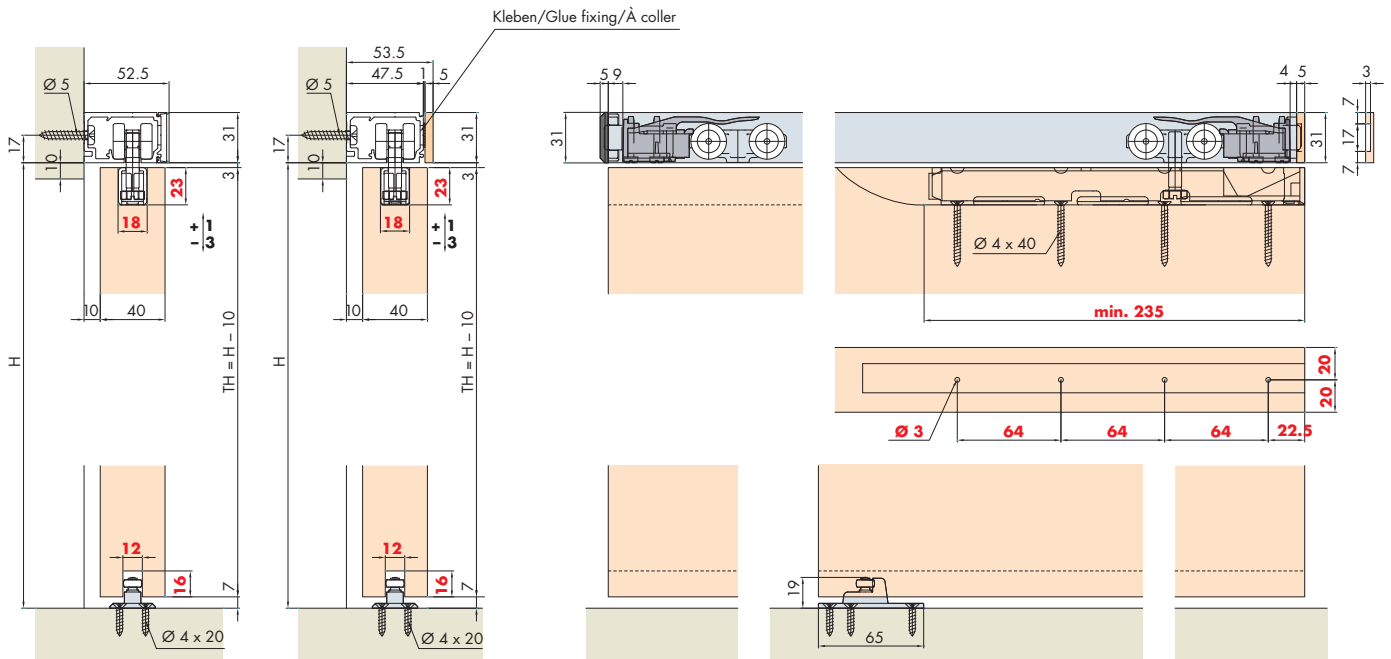

**Garnituren / Sets / Garnitures**

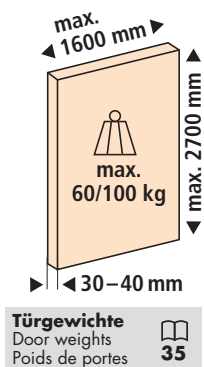

| EKU-PORTA 60/100  |   |
|-------------------|---|
| 1 Türe Door Porte | 60 No. 057.3133.072<br>100 No. 057.3133.071 |
| 2x                | 2x  |
| 2x                | 2x  |
| 1x                | 1x  |

| EKU-PORTA 60      |                  |
|-------------------|------------------|
| 1 Türe Door Porte | No. 057.3136.071 |
| 2x                | 2x               |
| 2x                | 2x               |
| 2x                | 1x               |
| 2x                | 2x               |
| 2x                | 2x               |
| 2x                | 2x               |
| 2000x47.5x31 mm   |                  |

| EKU-PORTA 100     |                  |
|-------------------|------------------|
| 1 Türe Door Porte | No. 057.3137.071 |
| 2x                | 2x               |
| 2x                | 2x               |
| 2x                | 1x               |
| 2x                | 2x               |
| 2x                | 1x               |
| 2x                | 1x               |
| 2x                | 1x               |
| 2000x47.5x31 mm   |                  |
| 2000x7.5x31 mm    |                  |
| 1x                |                  |

**Einbauvariante**  
Mounting options  
Variantes de montage

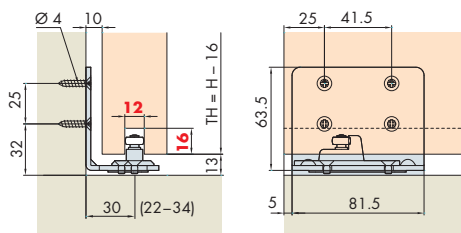

**Zubehör / Accessories / Accessoires**

**Einfachlaufschiene, Alu eloxiert, gelocht**  
Running track, aluminium anodized, pre-drilled  
Rail de roulement, en alu anodisé, perforé

| Gr./Size | Art. No.     |
|----------|--------------|
| 2500 mm  | 057.3112.250 |
| 3500 mm  | 057.3112.350 |
| 6000 mm  | 057.3112.600 |

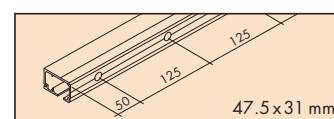

**Clip-Blende, Alu eloxiert, für Wandmontage**  
Clip panel, aluminium anodized, for wall mounting  
Cache à clipser, en alu anodisé, montage mural

| Gr./Size | Art. No.     |
|----------|--------------|
| 2500 mm  | 057.3113.250 |
| 3500 mm  | 057.3113.350 |
| 6000 mm  | 057.3113.600 |

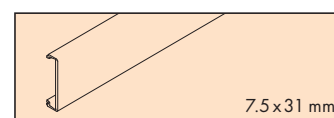

**Endkappen-Set, Kunststoff anthrazit, inkl. Sicherungsklammern, für Alublende** 057.3131.072  
End cap set, plastic anthracite, incl. limiter, for aluminium panel  
Jeu d'embouts, plastique anthracite, avec limiteur, pour cache en alu

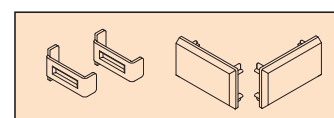

**Sicherungsklammern für Holzblende** 057.3126.071  
Limiter for wooden panel  
Limiteur pour cache en bois

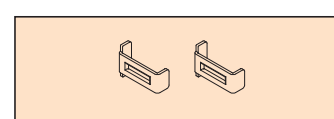

**Sonderzubehör / Special accessories / Accessoires spéciaux:** ☐ 22  
**Einzelteile / Components / Pièces détachées:** ☐ 24

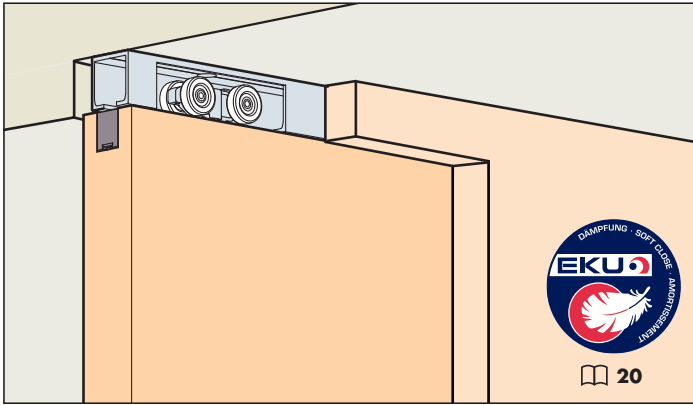

**System: Laufschiene für Deckenmontage, Einbau in der Tasche, für 1 Holztüre bis 60/100 kg.**

System: Running track for ceiling mounting, door mounted in a pocket, for 1 wooden door up to 60/100 kg.

Système: Rail de roulement pour montage au plafond, porte escamotable, pour 1 porte en bois jusqu'à 60/100 kg.

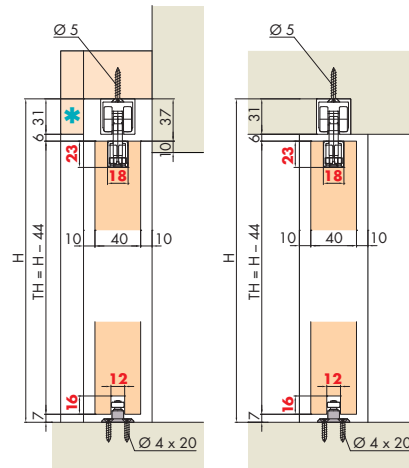
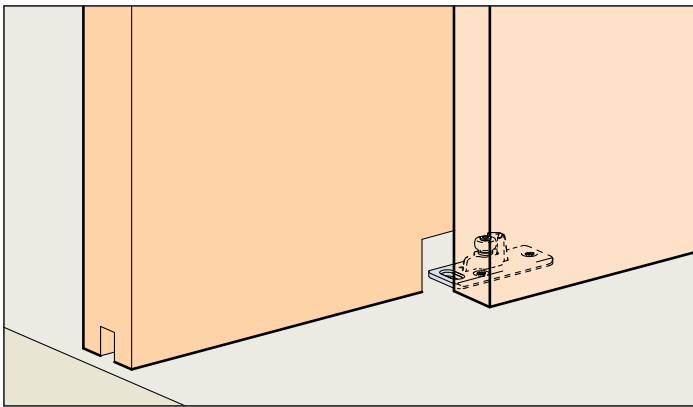

\* Für das Ein- und Ausschwenken darf eine Blende bis max. an die Unterkante der Schiene reichen.

At least one of the panels must end at the lower edge of the running track in order to be able to swivel the door inwards and outwards.  
Pour que le pivotement puisse s'effectuer, un cache pourra au maximum atteindre le bord inférieur du rail.

**Einbaubeispiele / Mounting examples / Exemples de montage**

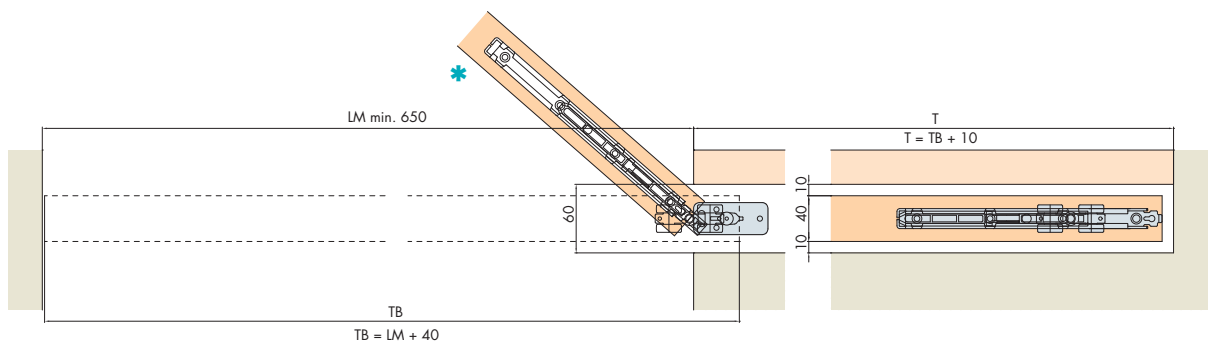
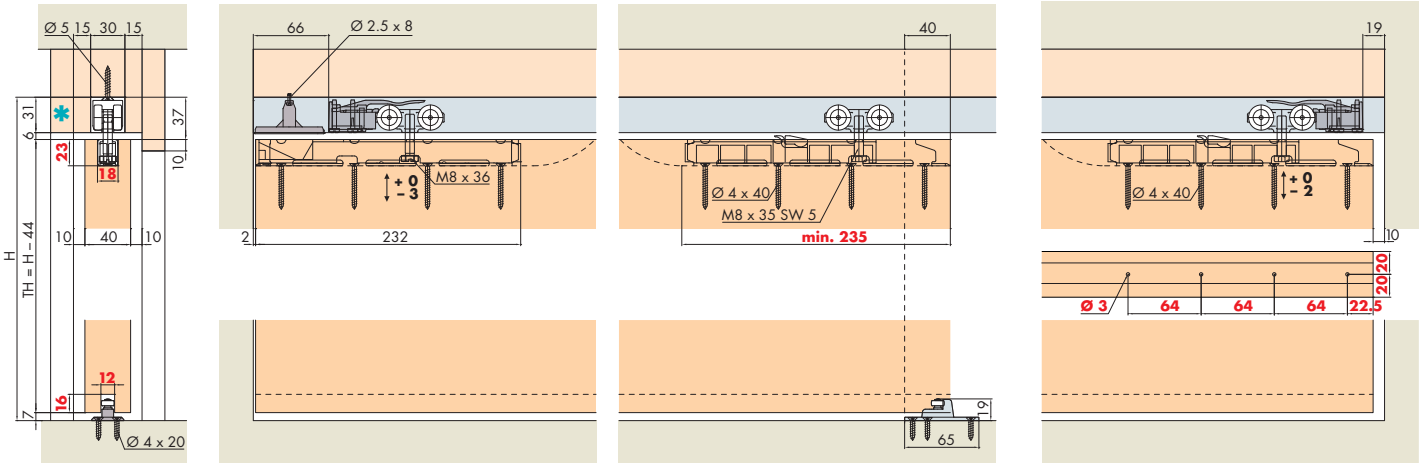

Türbearbeitung = rote Zahlen / Door treatment = red numbers / Traitement de portes = numéros en rouge





**Türgewichte**  
Door weights  
Poids de portes **35**

**Garnituren / Sets / Garnitures**

| EKU-PORTA 60/100               |   |
|--------------------------------|---|
| <b>1</b> Türe<br>Door<br>Porte | <b>60 No. 057.3133.074</b><br><b>100 No. 057.3133.073</b> |
| 1 x                            | 2 x   |
| 2 x                            | 2 x   |
| 1 x                            | 1 x   |
| 1 x                            | 1 x   |
| 1 x                            | 1 x   |
| 1 x                            | 1 x   |

**Zubehör / Accessories / Accessoires**

**Einfachlaufschiene, Alu, gelocht**

Running track, aluminium, pre-drilled  
Rail de roulement, en alu, perforé

Gr./Size

Art. No.

|         |              |
|---------|--------------|
| 1500 mm | 057.3016.150 |
| 1700 mm | 057.3016.170 |
| 2000 mm | 057.3016.200 |
| 2500 mm | 057.3016.250 |
| 6000 mm | 057.3016.600 |

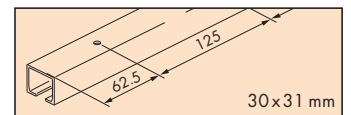

**Einfachlaufschiene, Alu eloxiert, gelocht**

Running track, aluminium anodized, pre-drilled  
Rail de roulement, en alu anodisé, perforé

|         |               |
|---------|---------------|
| 2000 mm | 057.3016.201  |
| 2500 mm | 057.3016.251  |
| 2500 mm | 057.3016.256* |
| 6000 mm | 057.3016.601  |

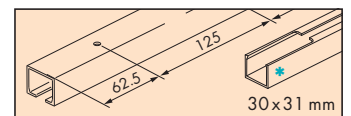

**Demontageschlüssel**

Removal key  
Clé de démontage

042.3119.101

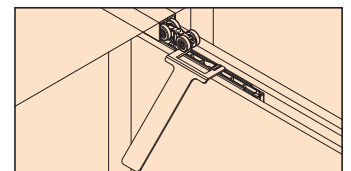

\*Montageöffnung und Abdeckkappe / Assembly opening and cover cap / L'ouverture de montage et cache: 21

Sonderzubehör / Special accessories / Accessoires spéciaux: 22

Einzelteile / Components / Pièces détachées: 24

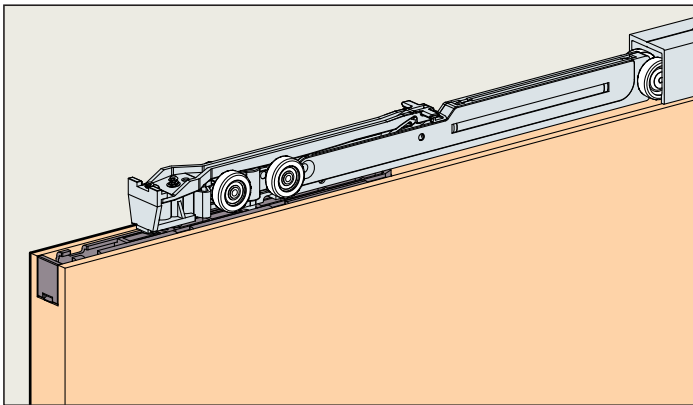

**System: Einzugsdämpfung, bis zu 60 oder 100kg, für leisen und sanften Schiebekomfort, bei obenlaufenden Holztüren für EKU-PORTA 60/100 Holz Systeme.**  
**Design: Einzugsdämpfung in Laufschiene integriert.**

System: Soft and self closing system, up to 60 or 100kg, for quiet and gentle sliding comfort with top-running wooden doors for EKU-PORTA 60/100 Wood systems.  
 Design: Soft and self closing system integrated in the running track.

Système : Amortissement pour retour automatique par traction jusqu'à 60 ou 100kg, pour un confort de coulissement doux et silencieux, pour portes en bois à roulement en haut pour systèmes EKU-PORTA 60/100 Bois.

Design : Amortissement pour retour automatique par traction intégré au rail de roulement.

**Einbaubeispiele / Mounting examples / Exemples de montage**

**Laufschiene mit Montageöffnung und Abdeckkappe / Running track with assembly opening and cover cap /**  
 Rail de roulement avec ouverture de montage et cache

**Laufschiene, deckenbündige Montage mit Montageöffnung und Abdeckkappe – erlaubt nachträgliche Montage der Einzugsdämpfung durch Montageöffnung.**  
 Running track, for installing flush with ceiling, assembly opening and cover cap – allows the soft and self closing system to be retrofitted through the assembly opening.  
 Rail de roulement, montage affleurant avec le plafond, ouverture de montage et cache – permet un montage ultérieur de l'amortissement pour retour automatique par traction.

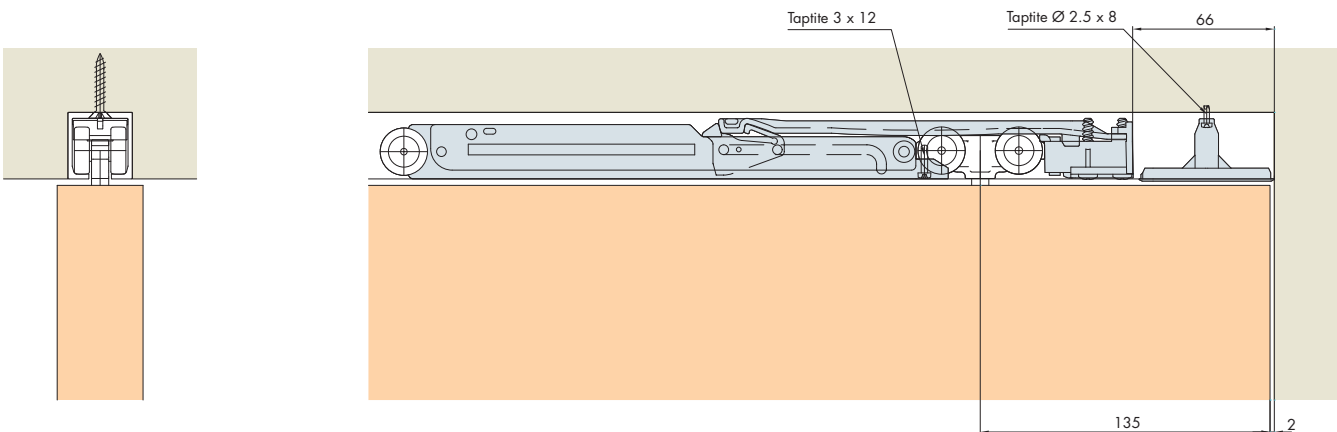

**Laufschiene ohne Montageöffnung und Abdeckkappe / Running track without assembly opening and cover cap /**  
 Rail de roulement sans ouverture de montage et cache

**Laufschiene, Wandmontage ohne Montageöffnung – Montage der Einzugsdämpfung sollte seitlich erfolgen.**  
 Running track, for wall mounting without assembly opening – soft and self closing system should be installed at the side.  
 Rail de roulement, montage mural sans ouverture de montage – le montage de l'amortissement pour retour automatique par traction doit s'effectuer sur le côté.

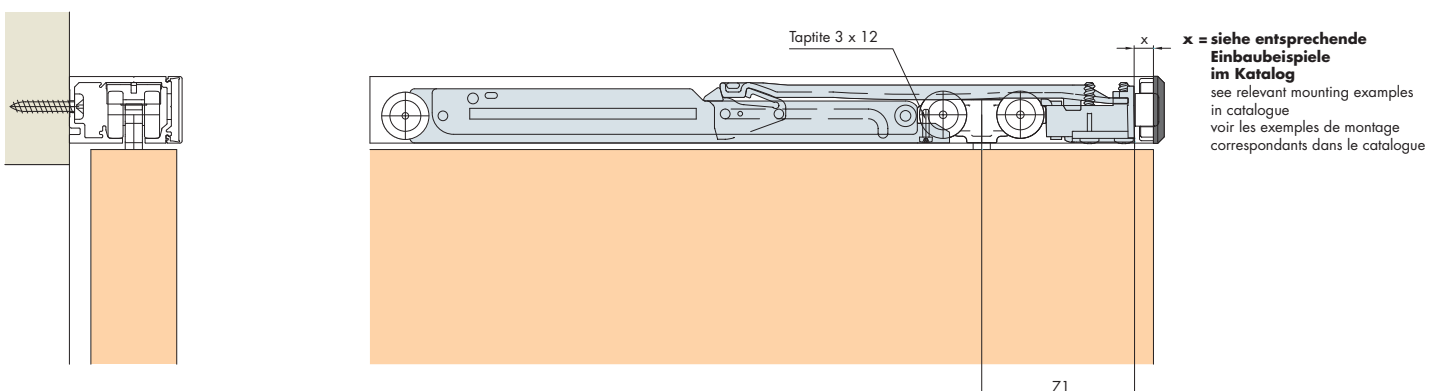

**Montageöffnung / Assembly opening / Apertura di montaggio**

Die Montageöffnung stellt sicher, dass die Lauftechnik und Einzugsdämpfung nachträglich eingebaut werden können, ohne dass die Laufschiene demontiert werden muss. Die Schiebetüre ist schnell montiert oder demontiert. Zudem erleichtert die Montageöffnung die Reinigung der Laufschiene, für einen ruhigen Lauf der Rollen. Für folgende Einbausituationen wird eine Montageöffnung empfohlen:

- bei deckenbündigem Einbau der Laufschiene
- wenn seitlicher Zugang für das Einfahren der Einzugsdämpfung nicht gewährleistet ist (min. 62mm)

The assembly opening ensures that the running system and the soft and self closing system can be retrofitted without the running track having to be removed. The sliding door can be installed or removed quickly. Moreover, the assembly opening makes it easier to clean the running track for smooth running of the rollers.

The assembly opening is recommended for the following installation situations:

- with running track installed flush with the ceiling
- if side access for retracting the soft and self closing system is not available (min. 62mm)

L'ouverture de montage garantit la possibilité d'un montage ultérieur de la technique de roulement et de l'amortissement pour retour automatique par traction sans qu'il soit nécessaire de démonter le rail de roulement. La porte coulissante peut ainsi être rapidement montée et démontée. Par ailleurs, l'ouverture de montage facilite le nettoyage du rail de roulement pour une course silencieuse des galets.

L'ouverture de montage est recommandée pour les situations de montage suivantes:

- montage du rail de roulement affleurant au plafond
- lorsqu'un accès latéral pour la mise en place de l'amortissement pour retour automatique par traction n'est pas assuré (min. 62mm)

**Zubehör / Accessories / Accessoires**

**Fräslöhre für Montageöffnung**

Routing jig for assembly opening

Gabarit de fraisage pour ouverture de montage

**Nutfräser HM (Hartmetall)**

Groove cutter HM (hard metal)

Fraise à rainurer HM (métal dur)

**Garnituren / Sets / Garnitures**

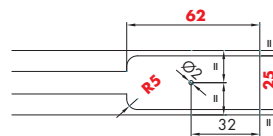
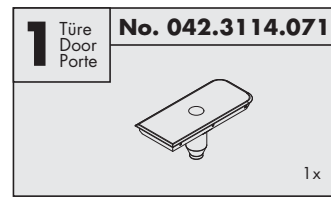

**10-60kg No. 042.3102.072**  
**61-100kg No. 042.3102.071**

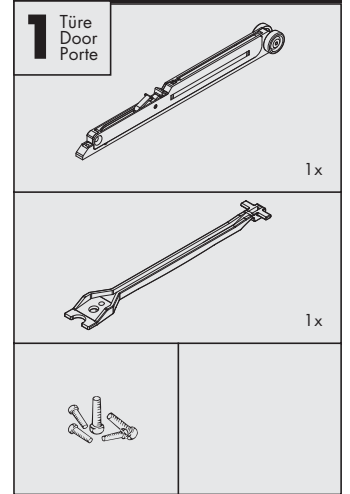

|  |   |   |
|--|---|---|
| Dämpfen in Schliessrichtung<br>Soft closing function in closing direction<br>Amortissement dans le sens de fermeture<br>➔  | ▲ 10-60kg<br>042.3102.072<br>▲ 61-100kg<br>042.3102.071 | 1 x bestellen<br>Order 1 x<br>Commander 1 x |
| Dämpfen in Schliess- und Öffnungsrichtung<br>Soft closing function in opening and closing direction<br>Amortissement dans le sens de fermeture et d'ouverture<br>↔ | ▲ 10-60kg<br>042.3102.072<br>▲ 61-100kg<br>042.3102.071 | 2 x bestellen<br>Order 2 x<br>Commander 2 x |

Art. No.

042.3118.071

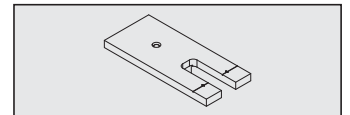

600.0000.309

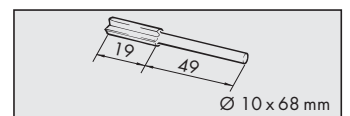

**Dämpfen in Schliessrichtung / Soft closing in closing direction / Amortissement dans le sens de fermeture**

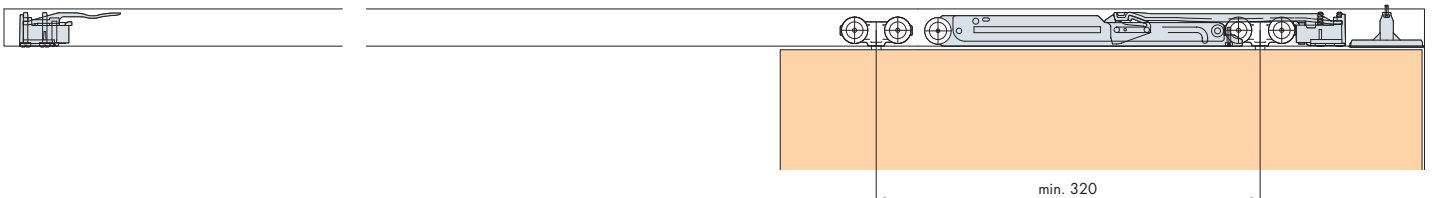

**Dämpfen in Schliess- und Öffnungsrichtung / Soft closing in closing and opening direction / Amortissement dans le sens de fermeture et d'ouverture**

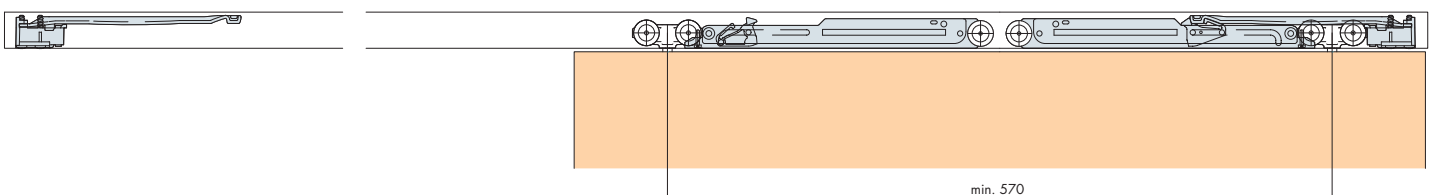

## EKU-PORTA 45/60/100

Gr./Size

Art. No.

**Winkel-Set für Wandmontage von Laufschiene,  
Stahl verzinkt (alle 500 mm)** 10x

057.3005.172

Angle-bracket set for wall mounting of running track, zinc-plated steel (every 500 mm)  
Lot d'équerres de fixation murale pour rail de roulement, en acier zingué (tous les 500 mm)

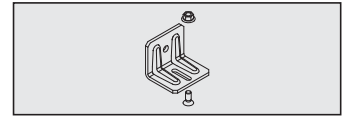
**Schienen-Verbindungs-U EKU-PORTA 60/100, Stahl verzinkt, gelocht**

057.3025.101

Track connecting U-piece EKU-PORTA 60/100, zinc-plated steel, pre-drilled  
Raccord en U pour rails EKU-PORTA 60/100, en acier zingué, perforé

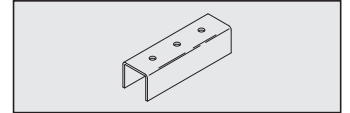
**Einfachlaufschiene EKU-PORTA 60/100, Stahl verzinkt, gelocht 6000 mm  
für Dämpfung nicht geeignet**

057.3022.600

Running track EKU-PORTA 60/100, zinc-plated steel, pre-drilled, unfit for soft close  
Rail de roulement EKU-PORTA 60/100, en acier zingué, perforé, pas approprié à l'amortissement

**Wandausgleichsprofil, Alu eloxiert, mit Dichtungsprofil**

2500 mm

042.3064.071

Wall compensation profile, aluminium anodized, with sealing profile

3000 mm

042.3064.072

Profil de compensation murale, en alu anodisé, avec profil d'étanchéité

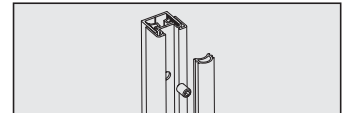
**Einwegabdeckung für Laufschiene 057.3016, Kunststoff**

2000 mm

057.3098.001

Disposable cover for running track 057.3016, plastic  
Recouvrement de rail 057.3016 à usage unique, plastique

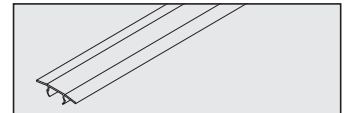
**Schienenreinigungsbürste, Kunststoff grau**

057.3099.071

Brush for track cleaning, plastic grey

Brosse de nettoyage pour rails, plastique gris

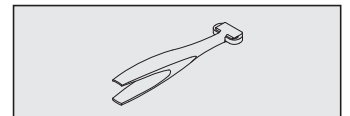
**T-Bodenführungs-Set EKU-PORTA 45 für Wandmontage**

057.3015.071

T-floor-guide set EKU-PORTA 45, for wall mounting

Guidage au sol en T EKU-PORTA 45, de fixation murale

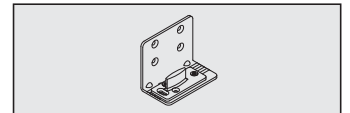
**Bodenführungs-Set mit Rolle EKU-PORTA 60/100, für Wandmontage**

057.3128.171

Floor-guide set with roller EKU-PORTA 60/100, for wall mounting

Guidage au sol avec chariot EKU-PORTA 60/100, de fixation murale

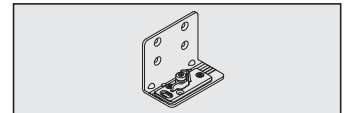

## EKU-PORTA 45

**Laufwerk, Gleitlager, Gehäuse Kunststoff rot, Rollen Kunststoff blau**

Runner, plain bearings, housing plastic red, rollers plastic blue

Chariot, patin glisseur, boîtier plastique rouge, galets plastique bleu

Art. No.

057.3044.071

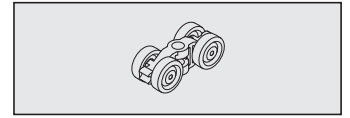
**Tragschraube M8 x 32, Stahl verzinkt**

Suspension bolt M8 x 32, zinc-plated steel

Vis porteuse M8 x 32, acier zingué

057.0123.104

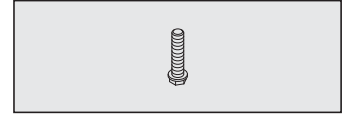
**Mutter M8, Stahl verzinkt**

Nut M8, zinc-plated steel

Ecrou M8, en acier zingué

767.0808.100

**Tragflansch, höhen- und seitenverstellbar, Stahl verzinkt**

Support bracket, height and lateral adjustable, zinc-plated steel

Etrier de fixation, réglage en hauteur et latéral, en acier zingué

057.3129.101

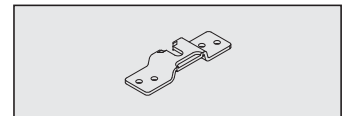
**T-Bodenführung, justierbar, Kunststoff antrazith**

T-floor-guide, adjustable, plastic anthracite

Guidage au sol en T, réglable, plastique anthracite

057.3010.001

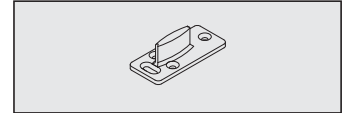
**Stopper, mit Rückhaltefeder, Kunststoff grau**

Stopper, with retention spring, plastic grey

Butée, avec ressort de blocage, plastique gris

057.3038.071

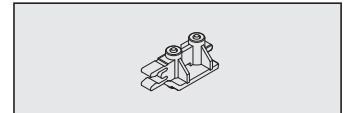



## EKU-PORTA 60/100

**Laufwerk EKU-PORTA 60, Gleitlager, Rollen Kunststoff blau**

Runner EKU-PORTA 60, plain bearings, rollers plastic blue  
Chariots EKU-PORTA 60, patin glisseur, galets plastique bleu

Art. No.

057.3115.071

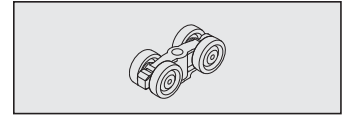
**Laufwerk EKU-PORTA 100, Kugellager, Rollen Kunststoff weiss**

Runner EKU-PORTA 100, ball bearings, rollers plastic white  
Chariot EKU-PORTA 100, roulement à billes, galets plastique blanc

057.3114.071

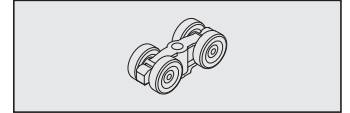
**Tragschraube M8 x 32, Stahl verzinkt**

Suspension bolt M8 x 32, zinc-plated steel  
Vis porteuse M8 x 32, en acier zingué

057.0123.104

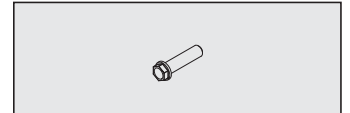
**Mutter M8, Stahl verzinkt**

Nut M8, zinc-plated steel  
Ecrou M8, en acier zingué

768.9005.101

**Tragflansch, höhen- und seitenverstellbar, Stahl verzinkt**

Support bracket, height and lateral adjustable, zinc-plated steel  
Etrier de fixation, réglage en hauteur et latéral, en acier zingué

057.3129.101

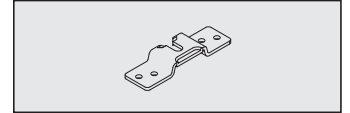
**Stopper, ohne Rückhaltefeder**

Stopper, without retention spring, plastic grey  
Butée, sans ressort de blocage, plastique gris

057.3073.071

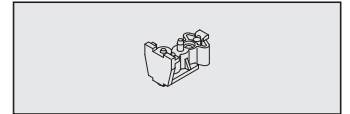
**Stopper, mit Rückhaltefeder, Kunststoff grau**

Stopper, with retention spring, plastic grey  
Butée, avec ressort de blocage, plastique gris

057.3073.072

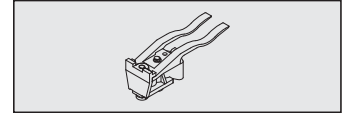
**Stopper, ohne Rückhaltefeder, Stahl verzinkt**

Stopper, without retention spring, zinc-plated steel  
Butée, sans ressort de blocage, en acier zingué

057.3002.171

**Wandpuffer, Gummi schwarz**

Wall buffer, black rubber  
Butoir mural, caoutchouc noir

024.0002.046

**Bodenführung mit Rolle, justierbar, Kunststoff antrazith**

Floor-guide with roller, adjustable, plastic anthracite  
Guidage au sol avec chariot, réglable, plastique anthracite

057.3120.071

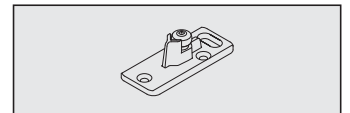

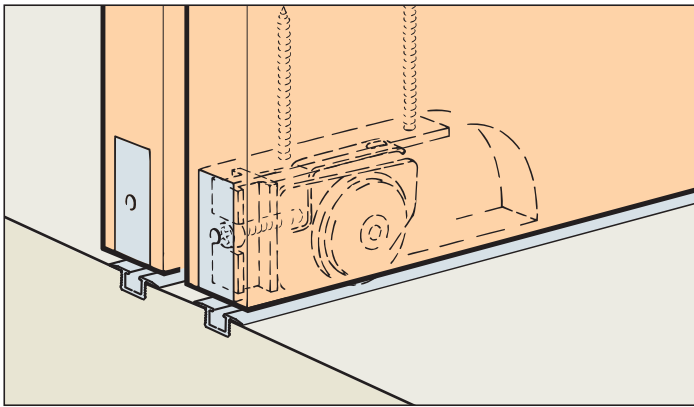

### System: Optionale 4-Punkt Führung

System: Optional 4 point guidance

Système: En option guidage à 4 points

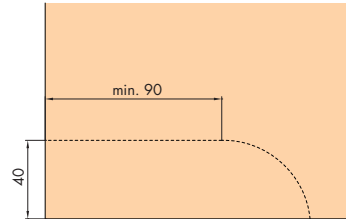

### Einbaubeispiele / Mounting examples / Exemples de montage

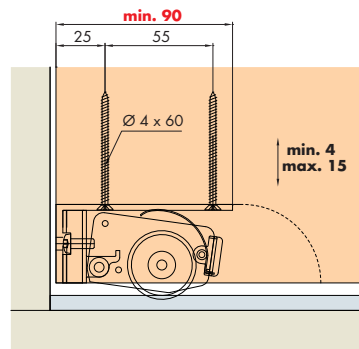
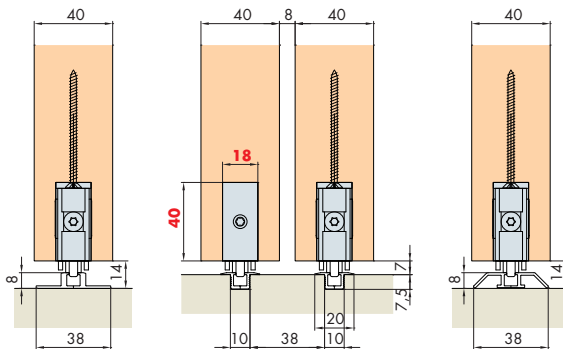

### Zubehör / Accessories / Accessoires

#### Bodenführung

Bottom guide

Guidage au sol

Gr./Size

Art. No.

042.3033.071

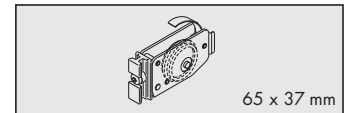

#### Adapter, Kunststoff anthrazit, für Holztüren, zu 042.3033.071

Adapter, plastic anthracite, for wooden doors, for 042.3033.071

Adaptateur, plastique anthracite, pour portes en bois, pour 042.3033.071

042.3036.001

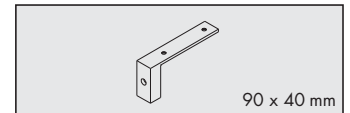

#### Einfachführungsschiene, Alu, eloxiert

Guide track, aluminium, anodized

Rail de guidage, en alu, anodisé

2500 mm

042.3089.250

3500 mm

042.3089.350

6000 mm

042.3089.600

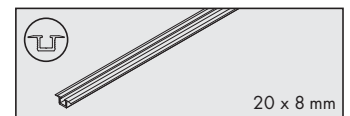

#### Schienenendstück, Kunststoff grau, zu 042.3089

Track end piece, plastic grey, for 042.3089

Pièce d'extrémité de rail, plastique gris, pour 042.3089

042.3090.081

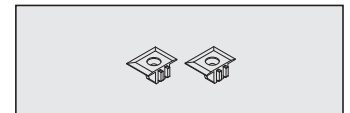

#### Einfachlaufschiene, Alu, eloxiert

Guide track, aluminium, anodized

Rail de guidage simple, en alu, anodisé

2500 mm

042.3040.250

3500 mm

042.3040.350

6000 mm

042.3040.600

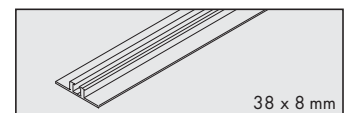

#### Einfachführungsschiene, Alu, eloxiert, zum Kleben

Guide track, aluminium, anodized, for glue fixing

Rail de guidage, en alu, anodisé, à coller

2500 mm

042.3080.250

3500 mm

042.3080.350

6000 mm

042.3080.600



#### Schienenendstück, Kunststoff grau, zu 042.3080

Track end piece, plastic grey, for 042.3080

Pièce d'extrémité de rail, plastique gris, pour 042.3080

042.3087.081

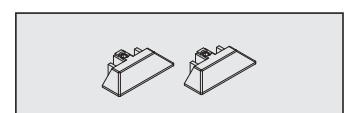

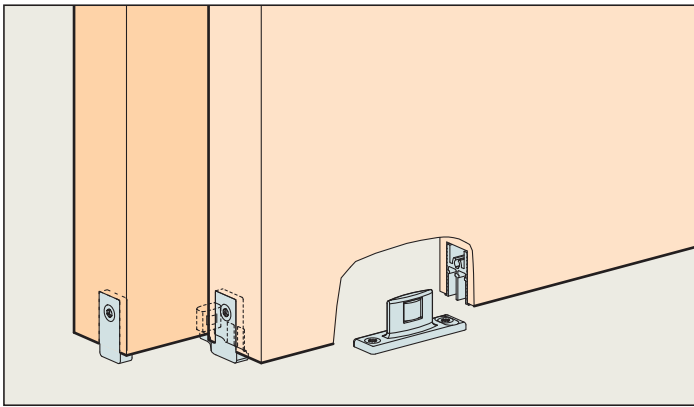

**System: Optionale Stapelung für barrierefreies und platzsparendes Stapeln von 2 Türen bis 60/100 kg.**

System: Optional stacking system for barrier-free and space saving Stacking system of 2 wooden doors up to 60/100 kg.

Système: En option rangement en parallèle pour passage sans obstacle et permettant un gain de place pour 2 portes jusqu'à 60/100 kg.

**Einbaubeispiele / Mounting examples / Exemples de montage**

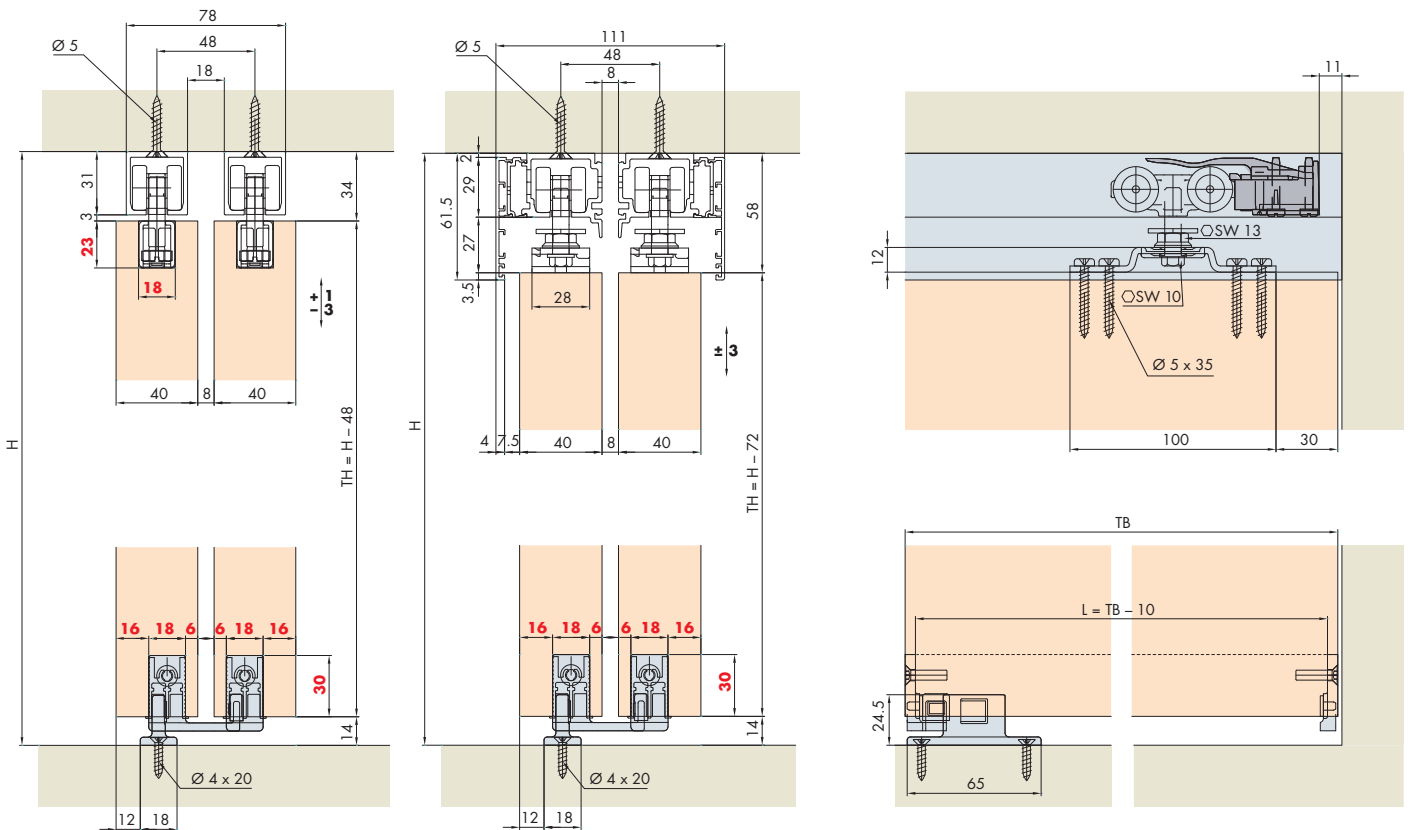

Türbearbeitung = rote Zahlen / Door treatment = red numbers / Traitement de portes = numéros en rouge

| Anzahl Türen<br>Number of doors<br>Nombre de portes      | Ausleger links<br>Left arm<br>Bras gauche<br>042.3097.071 | Ausleger rechts<br>Right arm<br>Bras droit<br>042.3098.071 | Abschlussplatte<br>End plate<br>Plaque d'extrémité<br>042.3099.071 |
|--|---|--|--|
| <b>2 Türen rechts</b><br>2 Right doors/2 Portes à droite |   | 1x   | 1x   |
| <b>2 Türen links</b><br>2 Left doors/2 Portes à gauche   | 1x  |  | 1x   |

**Garnituren / Sets / Garnitures**

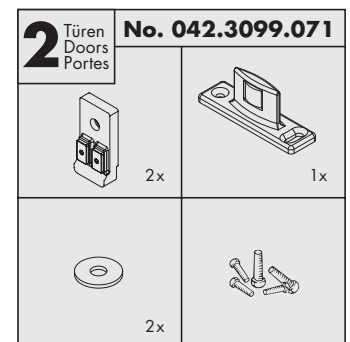
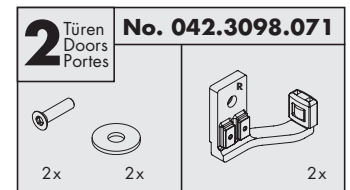
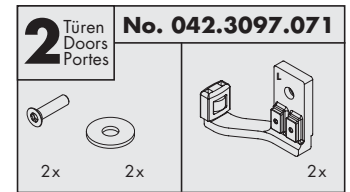

**Einbaubeispiel Ausleger links**

Mounting example **arm left**  
Exemple de montage **bras a gauche**

**Einbaubeispiel Ausleger rechts**

Mounting example **arm right**  
Exemple de montage **bras a droite**

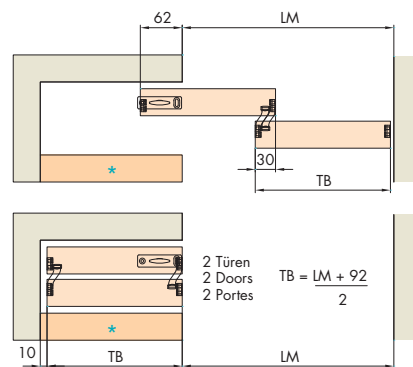
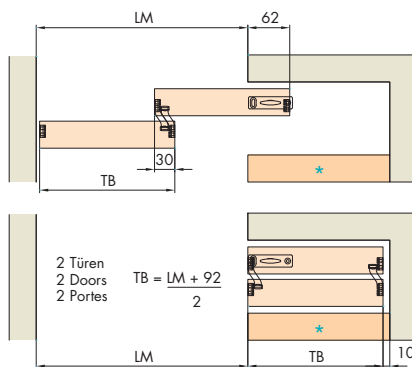
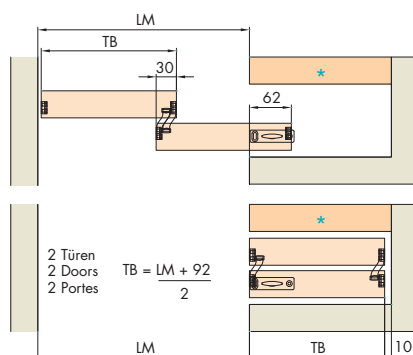
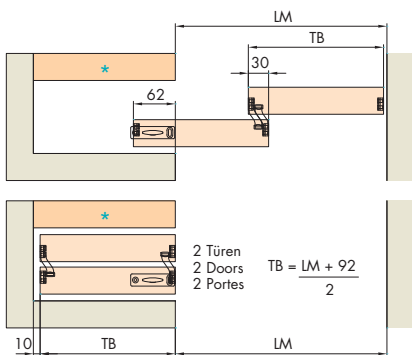

\* **Demontierbar für Montage**  
Removable for door mounting  
Démontable pour montage de porte

**Zubehör / Accessories / Accessoires**

**Doppelführungsschiene, Alu, zum Kleben**

Dual guide track, aluminium, for glueing  
Rail de guidage double, en alu, à coller

Gr./Size Art. No.

|         |              |
|---------|--------------|
| 2500 mm | 042.3088.250 |
| 3500 mm | 042.3088.350 |
| 6000 mm | 042.3088.600 |

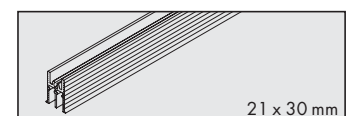

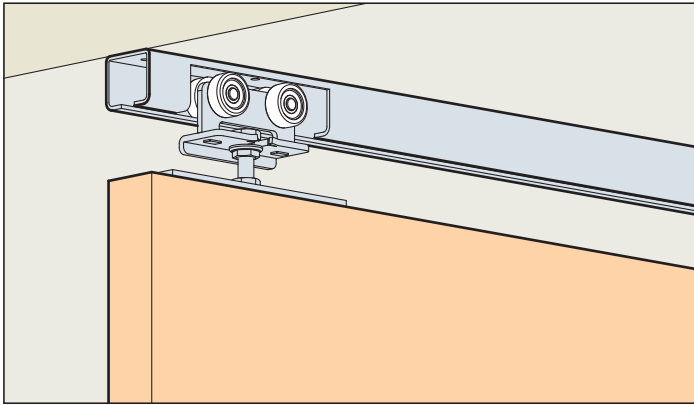

**System: Laufschiene für Decken- oder Wandmontage, für 1 Holztüre bis 300 kg.**

System: Running track for ceiling or wall mounting, for 1 wooden door up to 300 kg.

Système: Rail de roulement pour montage au plafond ou mural, pour 1 porte en bois jusqu'à 300 kg.

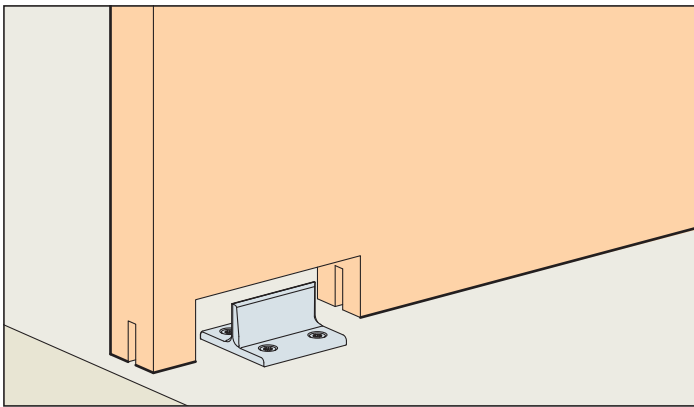

**Einbaubeispiele / Mounting examples / Exemples de montage**

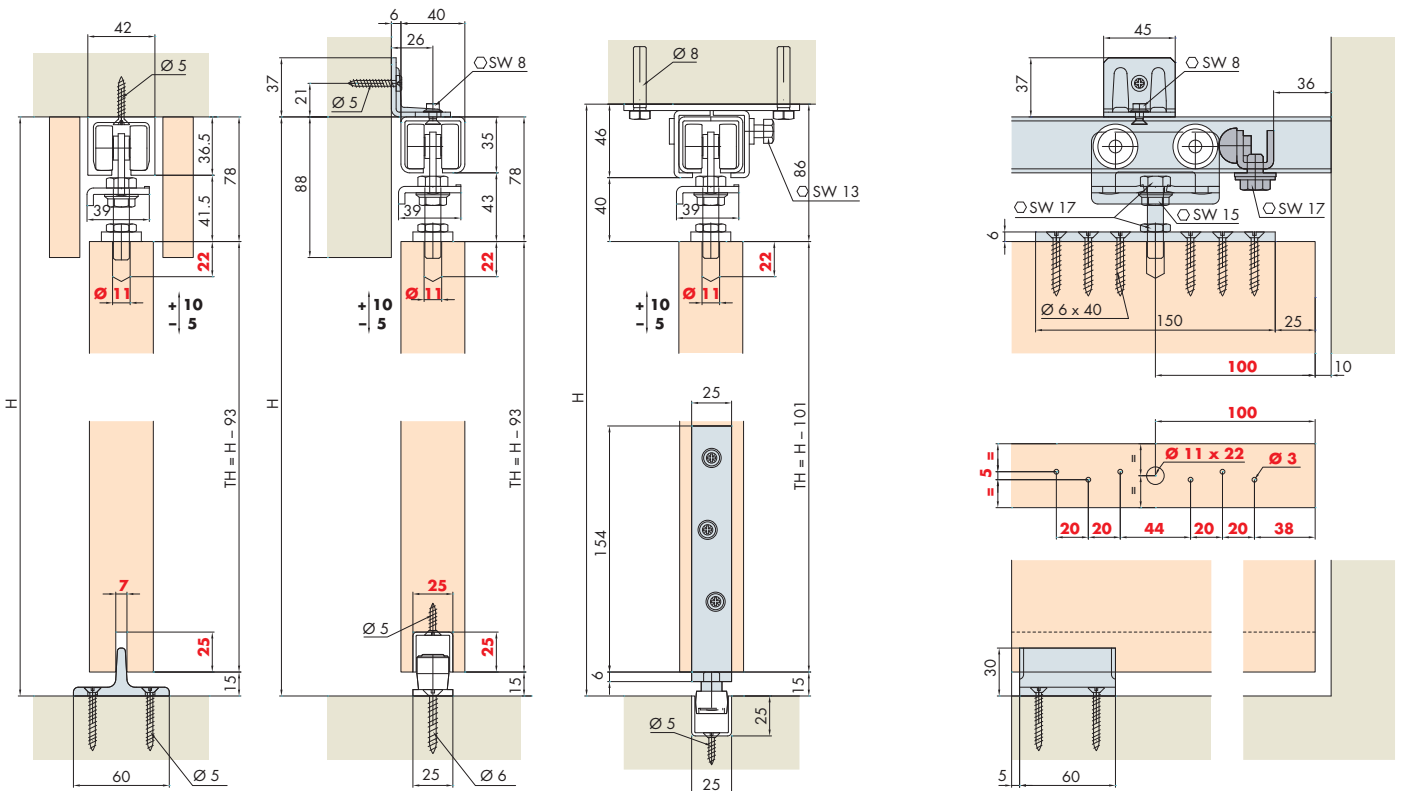



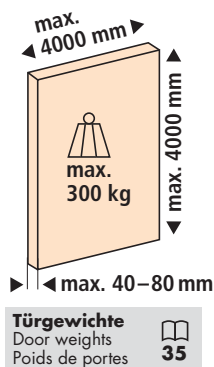
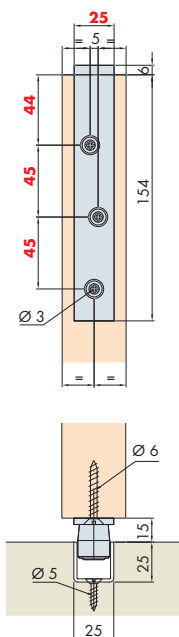
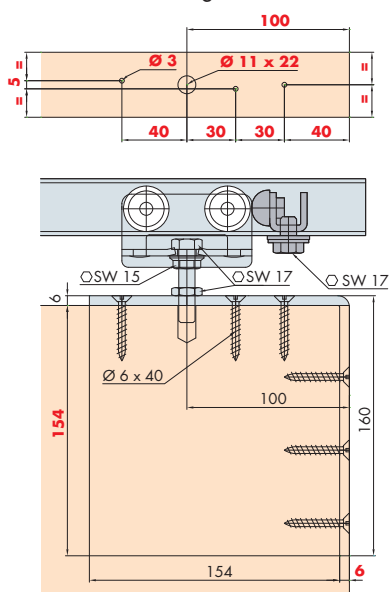

**Türbearbeitung = rote Zahlen / Door treatment = red numbers / Traitement de portes = numéros en rouge**

**Einbauvariante**

Mounting options  
Variantes de montage

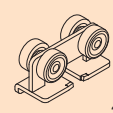
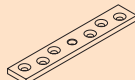

**Garnituren / Sets / Garnitures**

| 1 Türe / Door / Porte   |    | No. 058.3000.171  |    |
|---|----|---|----|
|  | 2x |  | 2x |
|  | 2x |  | 1x |
|  | 1x |  |    |

**Zubehör / Accessories / Accessoires**

**Einfachlaufschiene, Stahl**

Running track, steel  
Rail de roulement, en acier

**Einfachlaufschiene, Alu eloxiert, gelocht**

Running track, aluminium anodized, pre-drilled  
Rail de roulement, en alu anodisé, perforé

Gr./Size Art. No.

3000 mm 058.3002.300  
6000 mm 058.3002.600

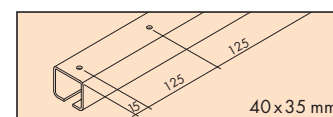

3000 mm 058.3016.300  
6000 mm 058.3016.600

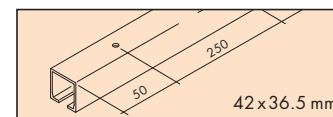

**Sonderzubehör / Special accessories / Accessoires spéciaux:** ☞ 32

**Einzelteile / Components / Pièces détachées:** ☞ 32

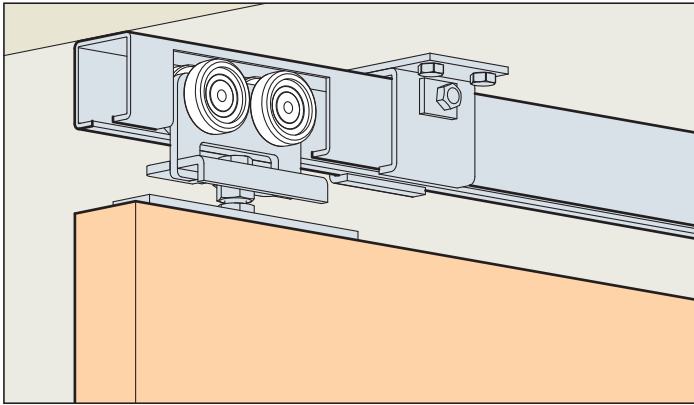

**System: Laufschiene für Decken- oder Wandmontage, für 1 Holztüre bis 600 kg.**

System: Running track for ceiling or wall mounting, for 1 wooden door up to 600 kg.

Système: Rail de roulement pour montage au plafond ou mural, pour 1 porte en bois jusqu'à 600 kg.

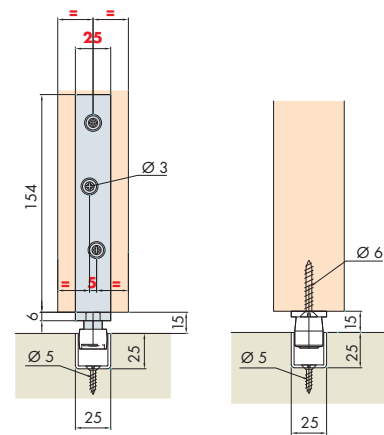
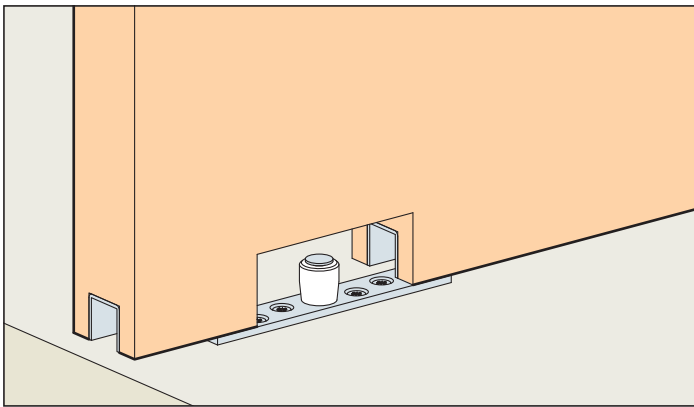

**Einbaubeispiele / Mounting examples / Exemples de montage**

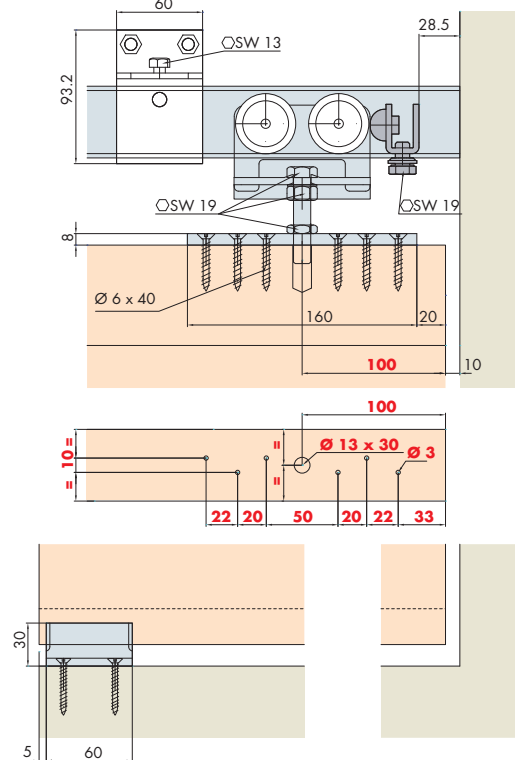
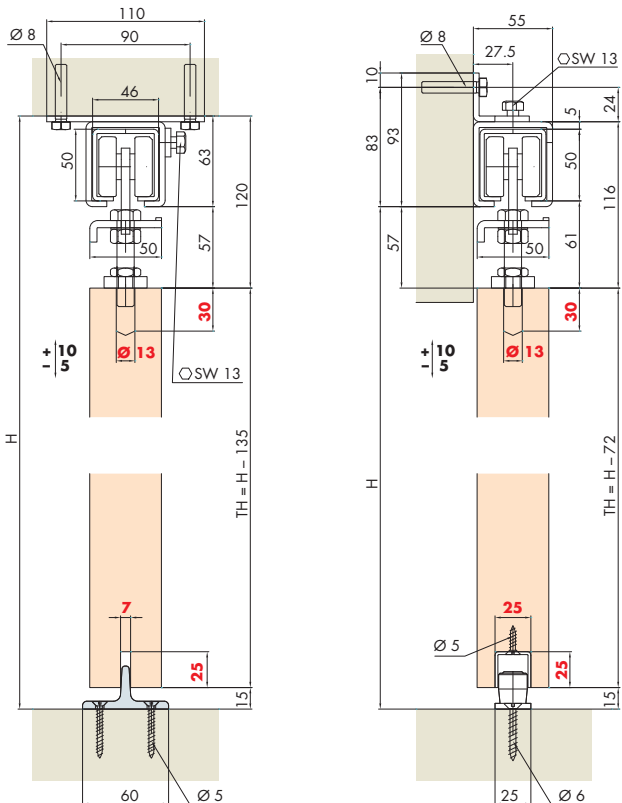

**Türbearbeitung = rote Zahlen / Door treatment = red numbers / Traitement de portes = numéros en rouge**





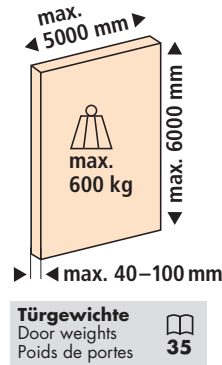
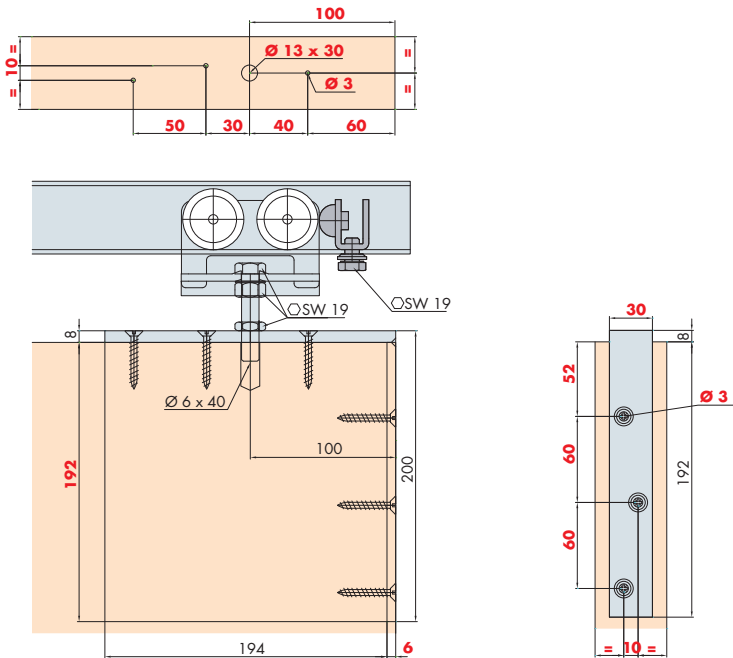

**Einbauvariante**

Mounting options  
Variantes de montage

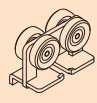
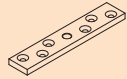

**Garnituren / Sets / Garnitures**

| 1 Türe / Door / Porte   |    | No. 059.3010.171  |    |
|---|----|---|----|
|  | 2x |  | 2x |
|  | 2x |  | 1x |
|  | 1x |  |    |

**Zubehör / Accessories / Accessoires**

**Einfachlaufschiene, Stahl**

Running track, steel  
Rail de roulement, en acier

Gr./Size

6000 mm

Art. No.

059.3000.600

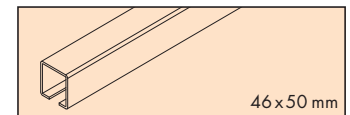

**Decken-Muffe inkl. Arretierschraube, Stahl verzinkt (alle 500 mm)**

Ceiling suspension bracket incl. locking bolt, zinc-plated steel (every 500 mm)  
Fixation de plafond vis d'arrêt incluse, en acier zingué (tout les 500 mm)

059.3002.171

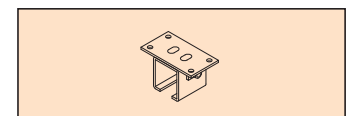

**Wand-Muffe inkl. Arretierschraube, Stahl verzinkt (alle 500 mm)**

Wall suspension bracket incl. locking bolt, zinc-plated steel (every 500 mm)  
Fixation murale vis d'arrêt incluse, en acier zingué (tout les 500 mm)

059.3003.171

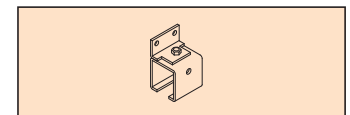



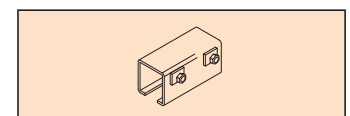

**Verbindungs-Muffe inkl. 2 Arretierschrauben, Stahl verzinkt**

Connecting sleeve incl. 2 locking bolts, zinc-coated steel  
Embout de raccord 2 vis d'arrêt incluse, en acier galvanisé

059.3001.171

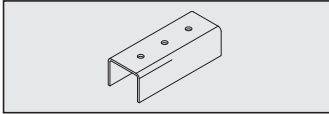
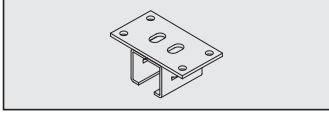
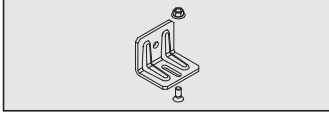

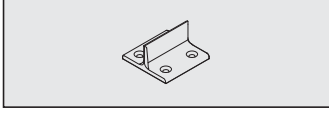
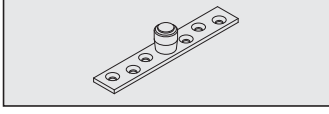
## EKU-PORTA 300 H

|   | Gr./Size | Art. No.     |   |
|---|----------|--------------|---|
| <b>Schienen-Verbindungs-U, Stahl verzinkt, gelocht, zu 058.3002</b><br>Track connecting U-piece, zinc-plated steel, pre-drilled, for 058.3002<br>Raccord en U pour rails, en acier zingué, perforé, pour 058.3002   |          | 058.3004.101 |    |
| <b>Decken-Muffe inkl. Arretierschraube, Stahl verzinkt (alle 500 mm), zu 058.3002</b><br>Ceiling suspension bracket incl. locking bolt, zinc-plated steel (every 500 mm), for 058.3002<br>Fixation de plafond vis d'arrêt incluse, en acier zingué (tout les 500 mm), pour 058.3002 |          | 058.3001.171 |    |
| <b>Winkel-Set für Wandmontage, Stahl verzinkt</b><br>Angle-bracket set for wall mounting, zinc-plated steel<br>Lot d'équerres de fixation murale, en acier zingué   | 10x      | 057.3005.172 |    |
| <b>Bodenführungsbolzen, zum Aufschrauben, zu 058.3010.101</b><br>Bottom guide pin, screwed-on, for 058.3010.101<br>Boulon à visser au sol, à visser, pour 058.3010.101  |          | 058.3015.171 |    |
| <b>T-Bodenführung, Stahl verzinkt</b><br>T-floor-guide, zinc-plated steel<br>Guidage au sol en T, en acier zingué   |          | 058.3011.101 |    |
| <b>Bodenführung mit Kunststoff-Rolle, Stahl verzinkt</b><br>Bottom guide with plastic roller, zinc-plated steel<br>Galet de guidage au sol avec galet en plastique, en acier zingué   |          | 058.3012.171 |   |
| <b>U-Führungsschiene, Stahl verzinkt, gelocht</b><br>U guide track, zinc-plated steel, pre-drilled<br>Rail de guidage en U, en acier zingué, perforé  | 6000 mm  | 058.3013.600 |  |

## EKU EINZELTEILE

## EKU-PORTA 300 H

|  | Art. No.     |   |
|--|--------------|---|
| <b>Laufwerk, Kugellager, Rollen Kunststoff</b><br>Runner, ball bearings, rollers plastic<br>Chariot, roulements à billes, galets en plastique                  | 058.3005.171 |  |
| <b>Tragschraube M10 x 45, Stahl verzinkt</b><br>Suspension bolt M10 x 45, zinc-plated steel<br>Vis porteuse M10 x 45, en acier zingué                          | 058.3006.171 |  |
| <b>Stopper, mit Gummipuffer, Stahl verzinkt</b><br>Stopper, with rubber buffer, zinc-plated steel<br>Butée, avec butoir en caoutchouc, en acier zingué         | 058.3008.171 |  |
| <b>Tragflansch, Stahl verzinkt</b><br>Supporting bracket, zinc-plated steel<br>Platine porteuse, en acier zingué   | 058.3009.101 |  |
| <b>Tragwinkel/Bodenführung, Stahl verzinkt</b><br>Supporting angle bracket/Bottom guide, zinc-plated steel<br>Equerre porteuse/Guidage au sol, en acier zingué | 058.3010.101 |  |

## EKU-PORTA 600 H

**Laufwerk, Kugellager, Rollen Kunststoff**

Runner, ball bearings, rollers plastic

Chariot, roulements à billes, galets en plastique

Gr./Size

Art. No.

059.3004.171

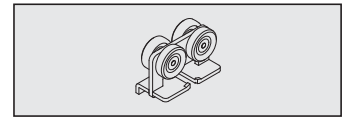
**Tragschraube M12 x 60, Stahl verzinkt**

Suspension bolt M12 x 60, zinc-plated steel

Vis porteuse M12 x 60, en acier zingué

059.3005.171

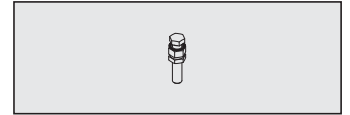
**Stopper, mit Gummipuffer, Stahl verzinkt**

Stopper, with rubber buffer, zinc-plated steel

Butée, avec butoir en caoutchouc, en acier zingué

059.3009.171

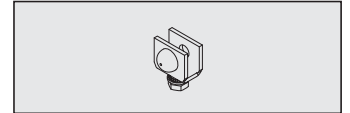
**Tragflansch, Stahl verzinkt**

Supporting bracket, zinc-plated steel

Bride porteuse, en acier zingué

059.3007.101

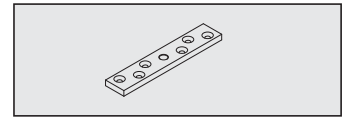
**Tragwinkel / Bodenführung, Stahl verzinkt**

Supporting angle bracket / Bottom guide, zinc-plated steel

Equerre porteuse / Guidage au sol, en acier zingué

058.3010.101

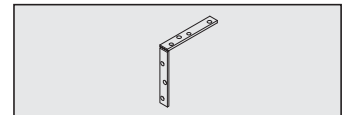
**Bodenführungsbolzen, zum Aufschrauben, zu 058.3010.101**

Bottom guide pin, screwed-on, for 058.3010.101

Boulon à visser au sol, à visser, pour 058.3010.101

058.3015.171

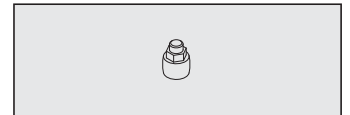
**T-Bodenführung, Stahl verzinkt**

T-floor-guide, zinc-plated steel

Guidage au sol en T, en acier zingué

058.3011.101

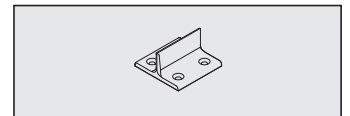
**Bodenführung mit Kunststoff-Rolle, Stahl verzinkt**

Bottom guide with plastic roller, zinc-plated steel

Galet de guidage au sol avec galet en plastique, en acier zingué

058.3012.171

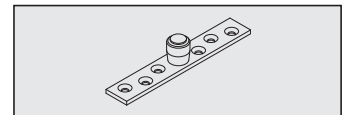
**U-Führungsschiene, Stahl verzinkt, gelocht**

U guide track, zinc-plated steel, pre-drilled

Rail de guidage en U, en acier zingué, perforé

6000 mm

058.3013.600

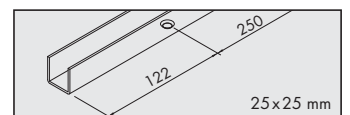

Getestet durch/Tested by/Testé par:

**Berner Fachhochschule  
Architektur, Bau und Holz  
CH-2504 Biel**

Bern University of Applied Sciences  
Architecture, Wood and Civil Engineering  
CH-2504 Biel

Haute école spécialisée bernoise  
Architecture, bois et génie civil  
CH-2504 Bienne



## QUALITY CERTIFICATE

EKU AG hereby certifies that the sliding door fittings of the product line **EKU-PORTA 100 Wood** comply with the requirements of DIN - EN 1527.

### Test Information

|                        |   |                   |
|------------------------|---|-------------------|
| Classification:        | DIN - EN 1527                               | - 6 2 0 - 0 - 1 3 |
| Door weight:           | 100 kg                                      |                   |
| Endurance test:        | 100'000 cycles                              |                   |
| Stop reliability:      | Complied with the requirements of DIN 68859 |                   |
| Retention reliability: | Complied with the requirements of DIN 68859 |                   |

### Additional Information

|                       |   |
|-----------------------|---|
| Ease of installation: | Requirements complied   |
| Tested by:            | Laboratory, School of Architecture, Civil and Wood Engineering, Biel   Test certificate No.: 7429-PZ-03 |
| Quality assurance:    | External and internal monitoring in accordance with ISO 9001:2000                                       |

**Heinz Schmidhauser**  
CEO/Managing Director

**Roland Stäheli**  
Quality Officer

*[Signature]*  
**Walter Gämperle**  
Head of Development



Sirnach, 10. August 2006

EKU AG, Schiebelösungen, Wilerstrasse 90, 8370 Sirnach, Switzerland, Tel. +41 (0)71 96 96 100  
Fax +41 (0)71 96 96 110, office@eku.ch, www.eku.ch Certified ISO 9001 - Member of the HAWA Group

# TÜRGEWICHTE

Door weights | Poids de vantaux

|  | <b>Spanplatte</b><br>Chipboard<br>Panneau d'aggloméré | <b>MDF</b><br>MDF<br>MDF |
|---|---|--------------------------|
|   | <b>D</b> <b>mm</b>                                    | <b>40 mm</b>             |
| B    x    H   |   |                          |
| 900 x 2000  | 40.5  | 52.6                     |
| 1200 x 2000   | 54.0  | 70.1                     |
| 1500 x 2000   | 67.5  | 87.6                     |
| 900 x 2200  | 44.5  | 57.9                     |
| 1200 x 2200   | 59.4  | 77.1                     |
| 1500 x 2200   | 74.2  | 96.4                     |
| 2000 x 2200   | 99.0  | —                        |
| 900 x 2400  | 48.6  | 63.1                     |
| 1200 x 2400   | 64.8  | 84.1                     |
| 1500 x 2400   | 81.0  | —                        |
| 2000 x 2400   | —   | —                        |
| 900 x 2600  | 52.6  | 68.4                     |
| 1200 x 2600   | 70.2  | 91.1                     |
| 1500 x 2600   | 87.7  | —                        |
| kg/m <sup>2</sup>   | <b>22.5</b>   | <b>29.2</b>              |

## TECHNISCHE DATEN

Technical data | Caractéristiques techniques

- EKU-Produkte sind nach DIN-EN 1527, inklusive Herausfalltest DIN-EN 15706, getestet.**  
 EKU products have been tested in accordance with DIN-EN 1527, incl. fall-out test in accordance with DIN-EN 15706.  
 Les produits EKU sont testés conformément à la DIN-EN 1527, y compris le test de chute selon DIN-EN 15706.
- Längenmasse der Standardprofile aus dem EKU-Sortiment unterliegen der DIN ISO 2768-1 c (+/- 4 mm)**  
 The length dimensions of the standard profiles from the EKU range are subject to DIN ISO 2768-1 c (+/- 4 mm )  
 Les longueurs des profilés standard de la gamme EKU sont conformes aux exigences de la norme DIN ISO 2768-1 c (+/- 4 mm )
- Max. Türgewichte und Türmasse siehe jeweilige Katalogseiten. Das max. Türgewicht darf nicht überschritten werden!**  
 Max. door weights and door dimensions see respective catalogue pages. The maximum door weight may not be exceeded!  
 Max. poids et dimensions de vantaux voir pages correspondantes du catalogue. Le poids de porte maximal ne doit pas être dépassé!
- Die Produkte sind nicht für Aussenanwendungen geeignet.**  
 The products are inapplicable for outdoor applications/use.  
 Les produits sont inappropriés pour des applications extérieures/l'usage extérieur
- Technische Änderungen vorbehalten.**  
 Subject to technical modifications.  
 Sous réserve de modifications techniques.





03 2016



Vertrieb über den Fachhandel  
Available through specialised distributors  
Distribution par le commerce spécialisé

**Per Mausclick zur  
intelligenten Schiebe-Lösung:**

With a click of the mouse  
you arrive at the intelligent  
sliding solution:

Un clic de souris et vous  
arrivez à la solution intelligente  
pour portes coulissantes:

[www.eku.ch](http://www.eku.ch)



EKU AG, Schiebelösungen, Wilerstrasse 90, 8370 Sirnach, Switzerland, Tel.+41 (0)71 96 96 100  
Fax +41 (0)71 96 96 110, office@eku.ch, Certified ISO 9001 – Member of the HAWA Group