

BAU

BUILDING BATIMENT

EKU PORTA
Glas | Glass | Verre



Schiebetechnik für Glastüren

Sliding technique for glass doors

Technique de coulisse pour
portes en verre

EKU 
Swiss Sliding Solutions







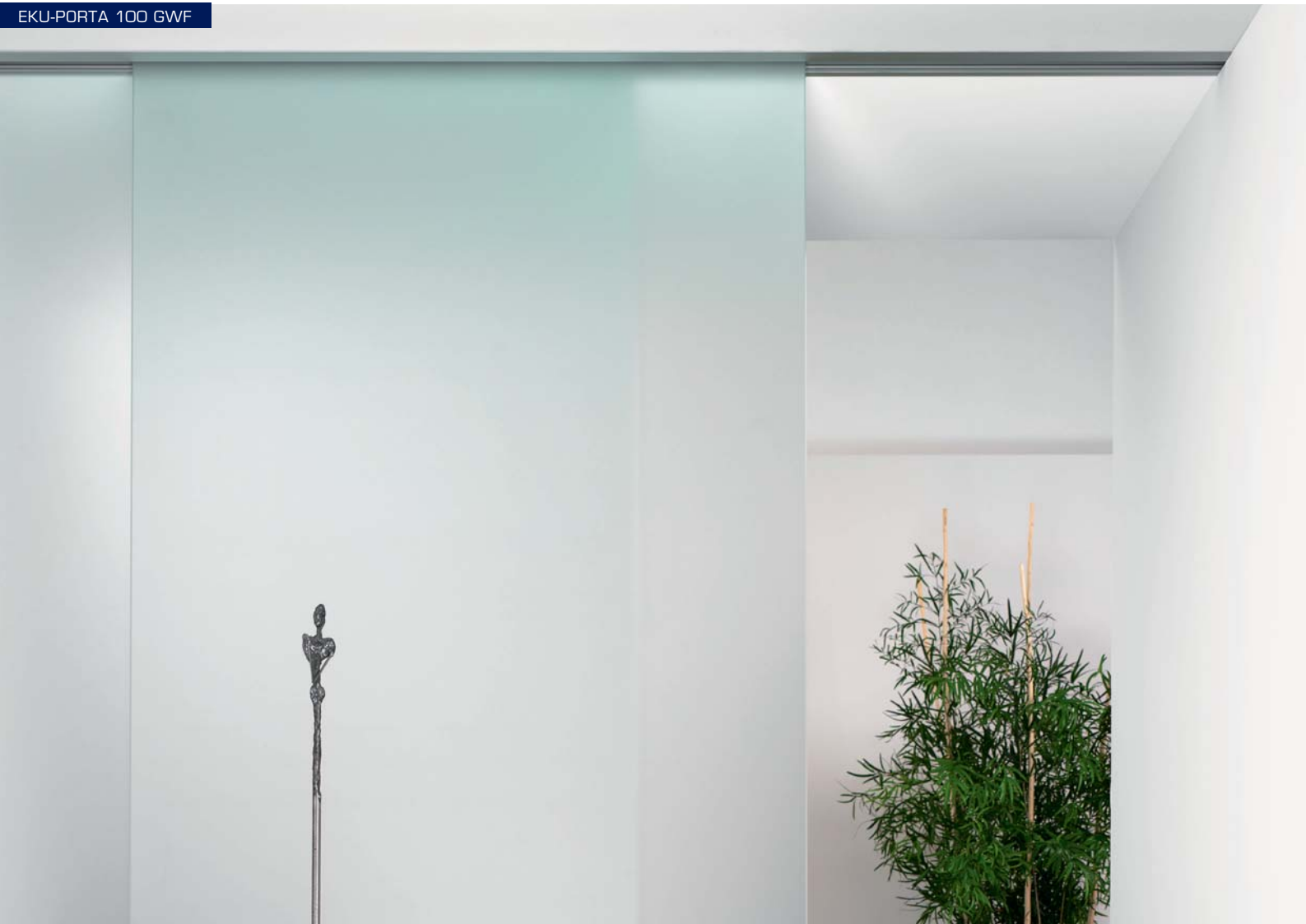



















EKU-PORTA 100 GMD

EKU-PORTA 100 GWF



EKU PORTA®

	EKU-PORTA 40 GE		📖	6/7
	EKU-PORTA 40 GE Glaswandmontage/ Glass wall mounting/ Montage mural sur vitrage		📖	8/9
	EKU-PORTA 100 GW		📖	14/15
	EKU-PORTA 100 GWF		📖	16/17
	EKU-PORTA 100 GW/GWF-Synchro		📖	18/19
	EKU-PORTA 100 G		📖	20/21
	EKU-PORTA 100 G/GF/GFO-Synchro		📖	22/23
	EKU-PORTA 100 GU		📖	24/25
	EKU-PORTA 100 GM		📖	26/27
	EKU-PORTA 100 GMD		📖	28/29
	EKU-PORTA 100 GF		📖	30/31
	EKU-PORTA 100 GFO		📖	32/33

EKU DÄMPFUNG

Soft close | Amortissement

	EKU-DÄMPFUNG EKU-Soft close EKU-Amortissement	📖	10/11 34/35
---	--	---	------------------------

EKU-Sonderzubehör EKU-Special accessories EKU-Accessoires spéciaux	📖	36
EKU-Einzelteile EKU-Components EKU-Pièces détachées	📖	37
EKU-Glasempfehlung EKU-Glass recommendation EKU-Types de verre recommandés	📖	38
Türgewichte Door weights Poids de portes	📖	39
Technische Daten Technical data Caractéristiques techniques	📖	39

	Tragkraft pro Türe Carrying capacity per door Capacité de charge par porte
System Système	
EKU PORTA®	100 GW
Modell Model Modèle	



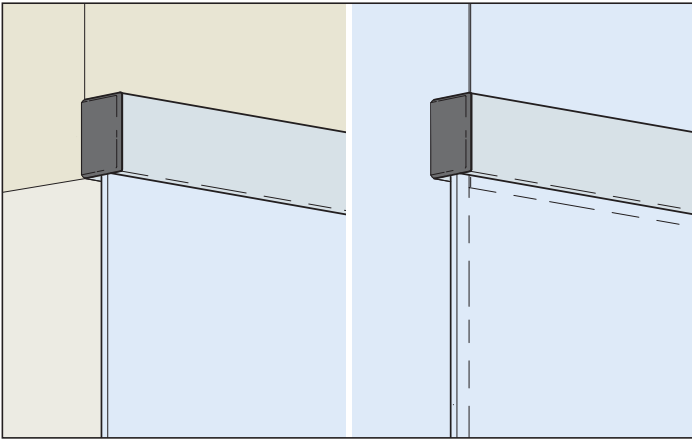

Design-Beschlag mit schlanken Laufschienen – keine Technik sichtbar

Designer fitting with slim running tracks – invisible running system
 Ferrure design avec rails de roulement étroits – avec technique invisible

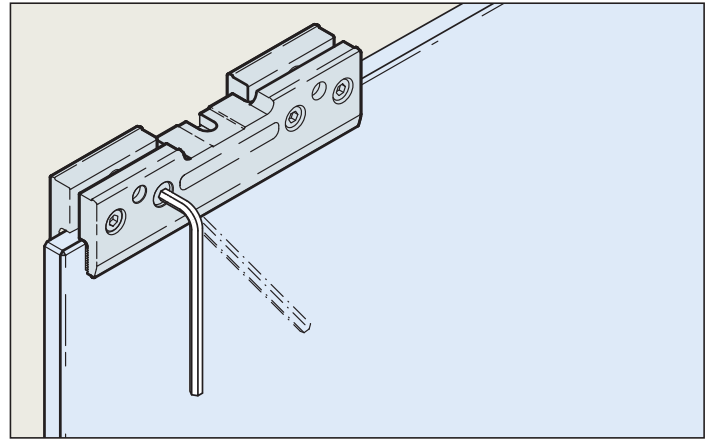

Klemmen ohne Glasbearbeitung (6–8 mm Glas)

Clamping without machining of the glass (6–8 mm Glas)
 Serrage sans usinage du verre (verre 6–8 mm)

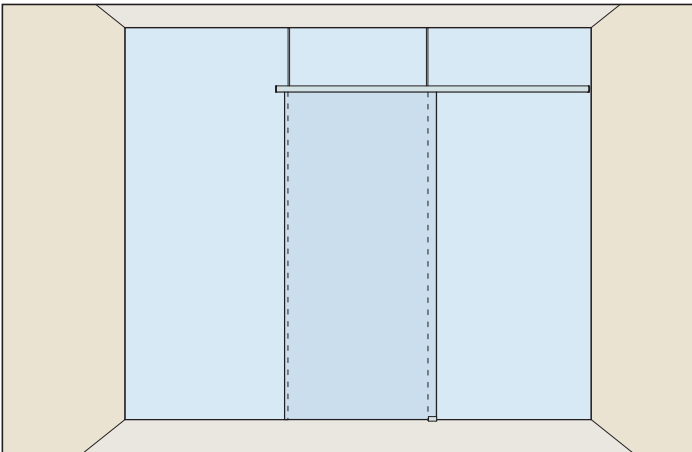

Design-Anwendungen für Montage an Glaswänden

Design applications for installation on glass walls
 Applications design pour montage sur parois en verre

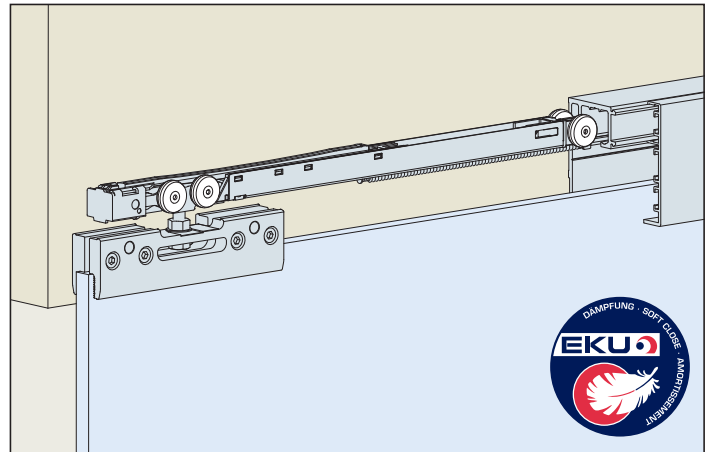

Unsichtbare Dämpfung – in Laufschiene integriert

Invisible soft close – integrated in running track
 Amortissement invisible – intégré au rail de roulement

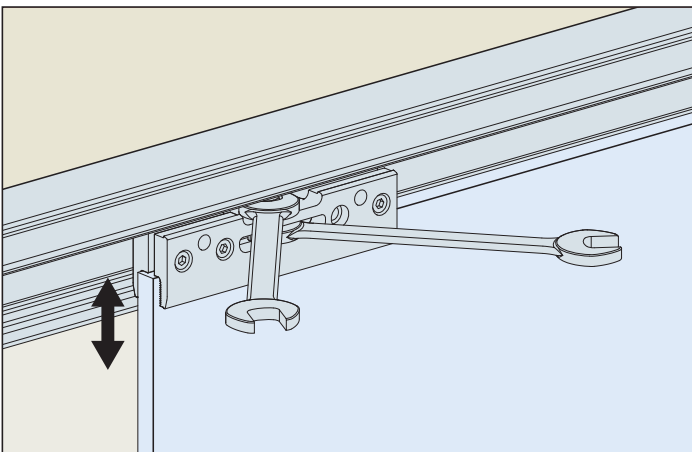

Bewährte Stoppertechnik und einfache Höhenverstellung

Well-tried stop system and easy height adjustment
 Technique de butée éprouvée et réglage facile de la hauteur

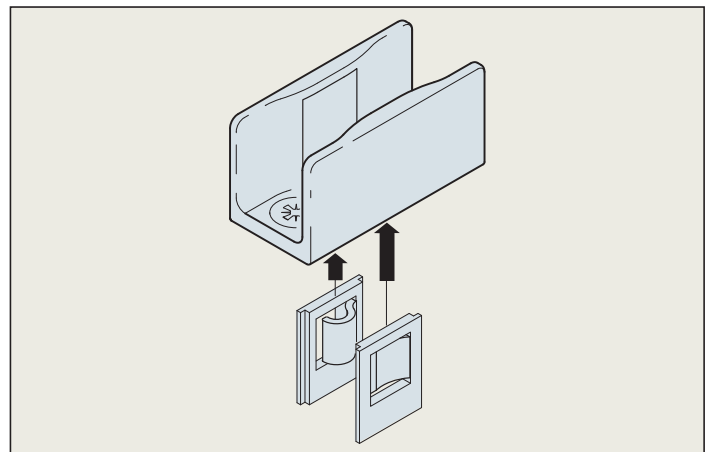

Bodenführung adaptierbar für 6 oder 8 mm Glas

Bottom guide adaptable for 6 or 8 mm glass
 Guidage au sol adaptable pour 6 ou 8 mm verre

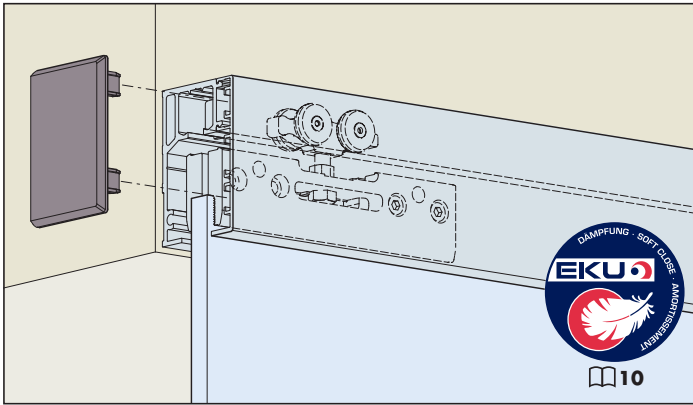

System: Laufschiene, Einbauhöhe 52 mm, Wandmontage für 1 Glastüre bis 40 kg.

System: Running track, installation height 52 mm, wall installation for 1 glass door up to 40 kg.

Système: Rail de roulement, hauteur d'installation 52 mm, montage mural pour 1 porte en verre jusqu'à 40 kg.

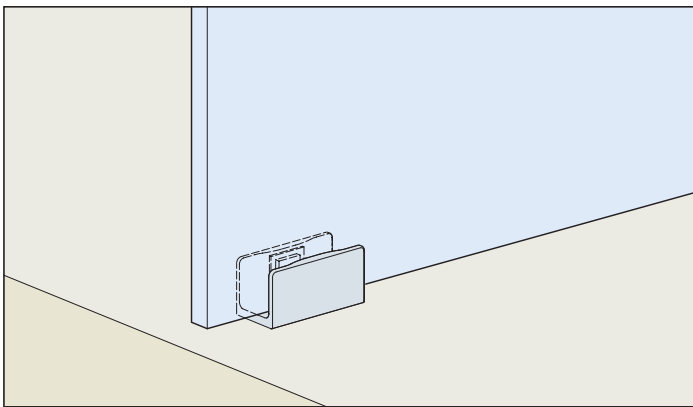

Einbauvariante / Mounting version /
Variante de montage

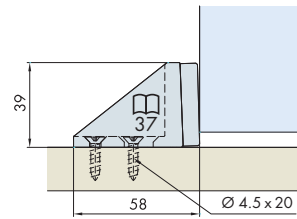

Einbaubeispiele / Mounting examples / Exemples de montage

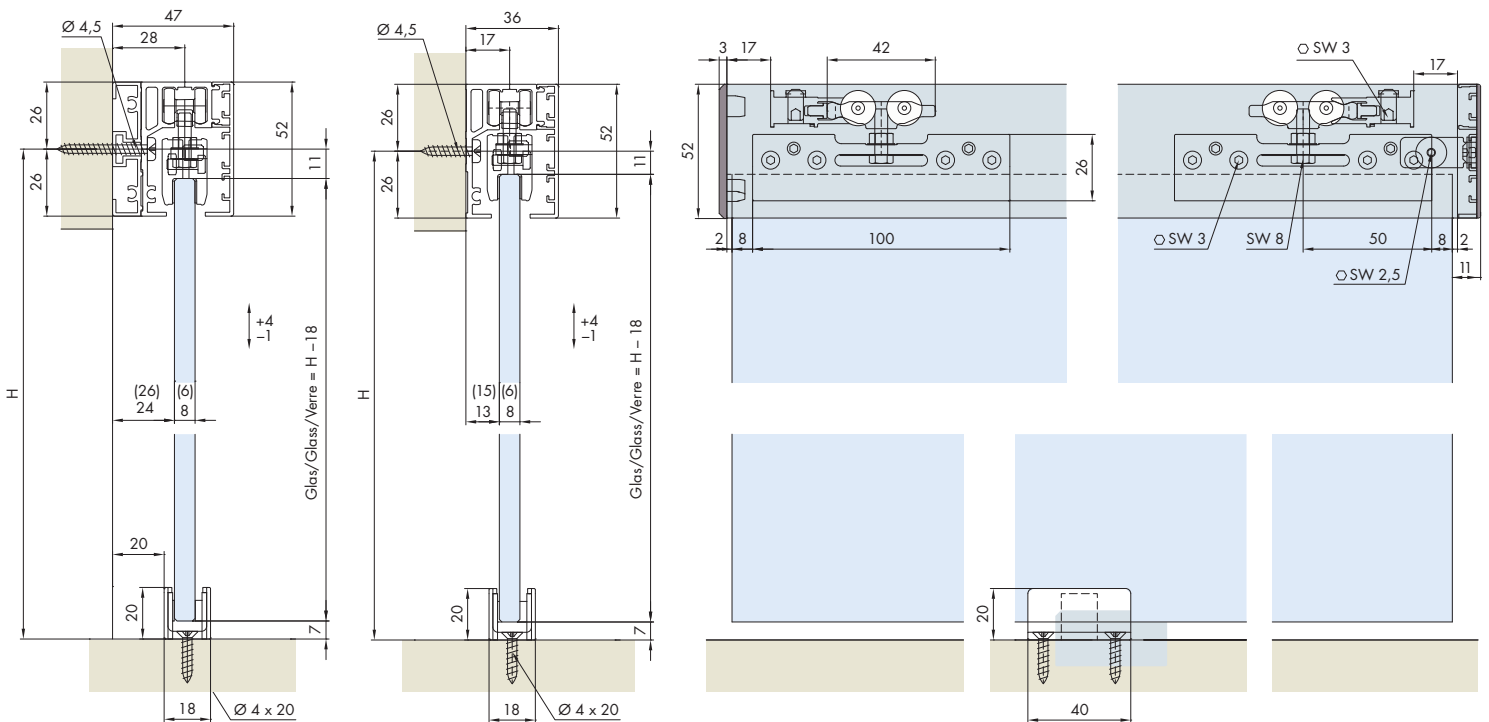

Varianten Blendenendstück /
 Panel end component versions /
 Variantes de jeu d'extrémités de cache

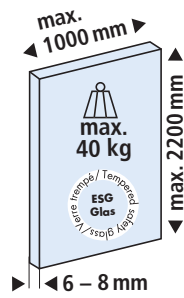
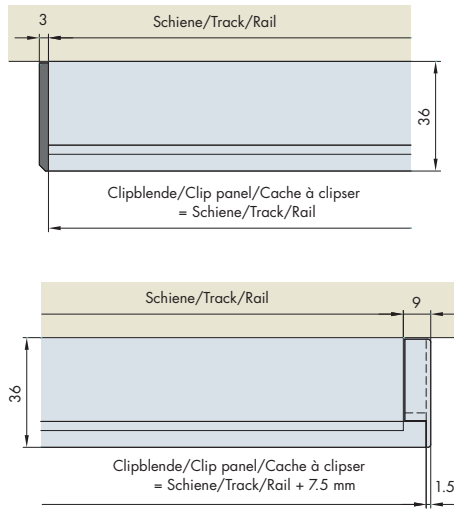

Türgewichte
 Door weights
 Poids de portes

39

Garnituren / Sets / Garnitures

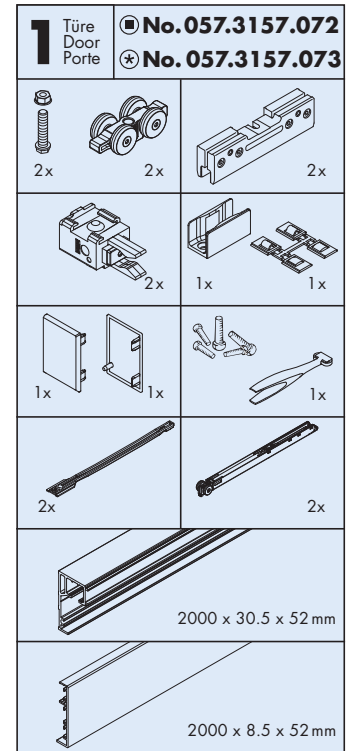
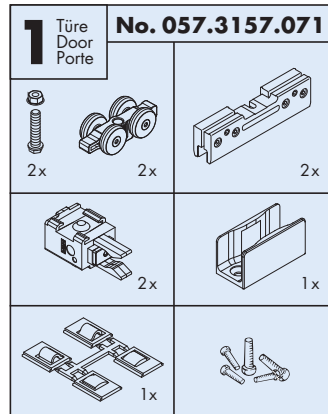

- **Eloxiert**
 Anodized
 Anodisé
- ⊛ **Edelstahloptik (Albea 25.4)**
 Stainless steel effect (Albea 25.4)
 Aspect inox (Albea 25.4)

Zubehör / Accessories / Accessoires

Laufschiene, Alu gelocht

Running track, aluminium pre-drilled
 Rail de roulement, en alu perforé

	Gr./Size	Art. No.
■	6000 mm	057.3146.600
⊛	6000 mm	057.3146.602



Clipblende zu 057.3146, Alu

Clip panel for 057.3146, aluminium
 Cache à clipser pour 057.3146, en alu

■	6000 mm	053.3195.600
⊛	6000 mm	053.3195.602

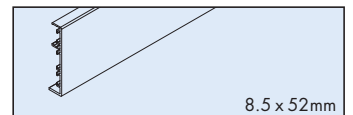

Endkappen-Set, Kunststoff anthrazit

End cap set, plastic anthracite
 Jeu d'embouts, plastique anthracite

	36 mm	053.3192.071
--	-------	--------------

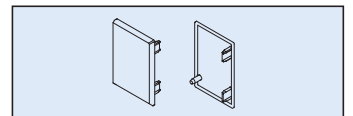

Endkappen-Set, Kunststoff anthrazit, für Glaswandmontage

End cap set, plastic anthracite, for glass wall mounting
 Jeu d'embouts, plastique anthracite, pour montage mural sur vitrage

	11 mm	057.3162.071
--	-------	--------------

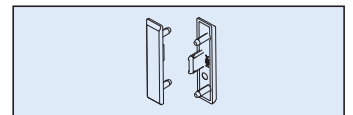

Blendenendstück-Set, Alu

Panel end component set, aluminium
 Jeu d'extrémités de cache, en alu

links, left, à gauche	■	36 mm	057.3107.071
rechts, right, à droite	■		057.3107.072
links, left, à gauche	⊛		057.3107.075
rechts, right, à droite	⊛		057.3107.076

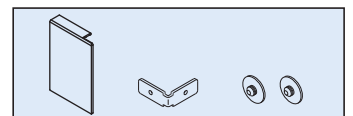

Blendenendstück-Set, Alu

Panel end component set, aluminium
 Jeu d'extrémités de cache, en alu

links, left, à gauche	■	47 mm	057.3107.081
rechts, right, à droite	■		057.3107.082

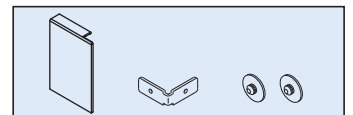

Distanzschiene, Alu eloxiert, gelocht, für Wandmontage

Spacer track, aluminium anodized, for wall mounting
 Rail d'écartement, en alu anodisé, pour montage mural

	2000 mm	057.3166.200
--	---------	--------------

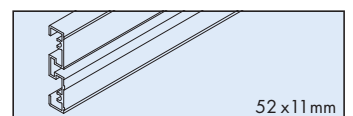

Sonderzubehör / Special accessories / Accessoires spéciaux: □ 36

Technische Daten / Technical data / Caractéristiques techniques: □ 39

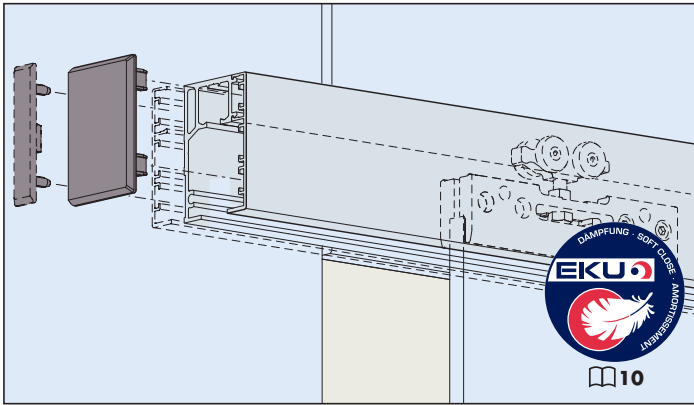

System: Glaswandmontage für EKU-PORTA 40 GE

System: Glass wall mounting for EKU-PORTA 40 GE

Système: Montage mural sur vitrage pour EKU-PORTA 40 GE

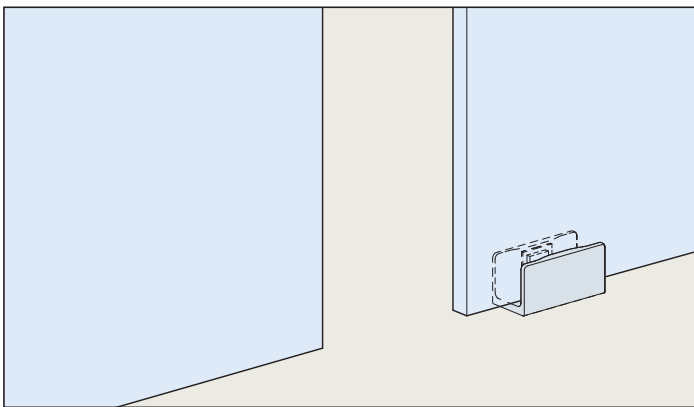
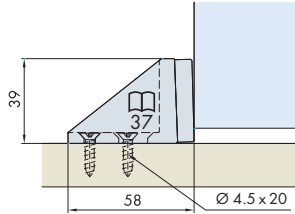

Einbauvariante / Mounting version / Variante de montage

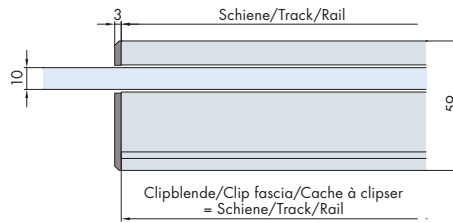

Einbaubeispiele / Mounting examples / Exemples de montage

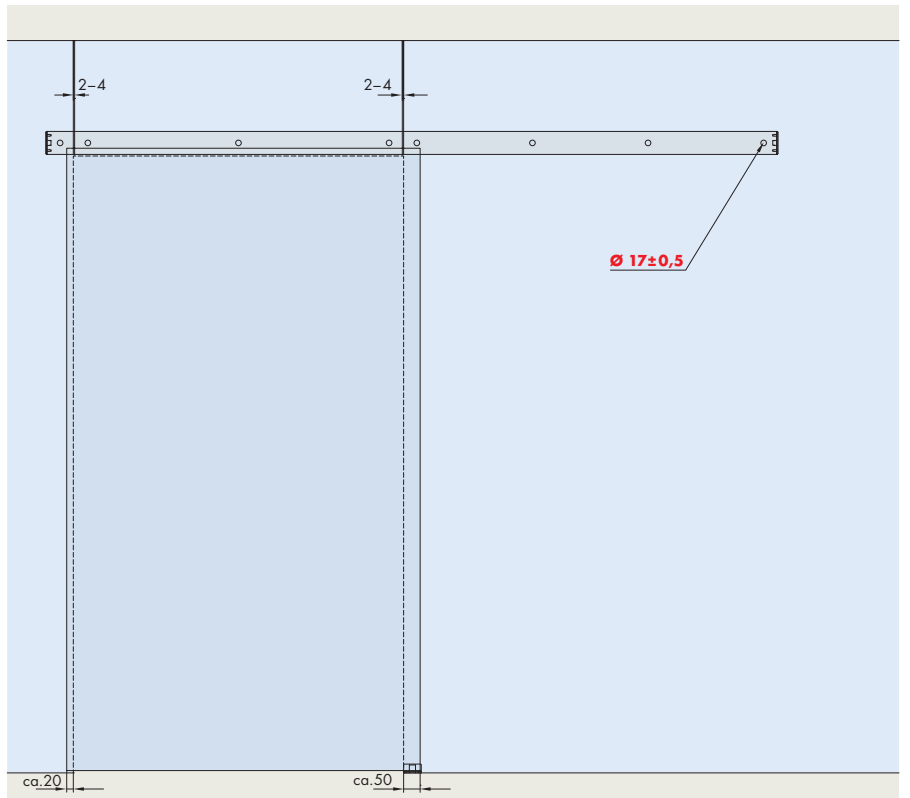
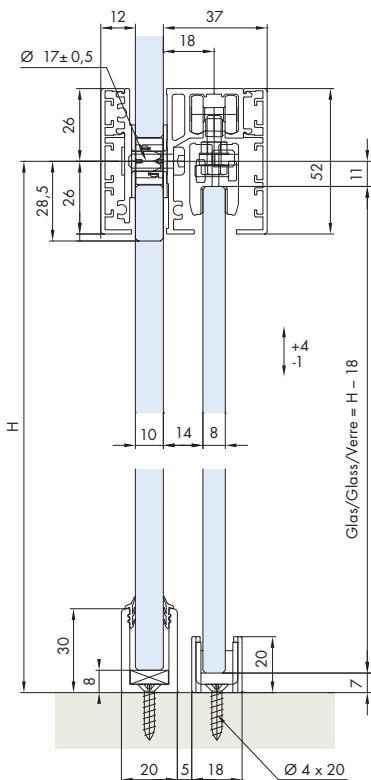
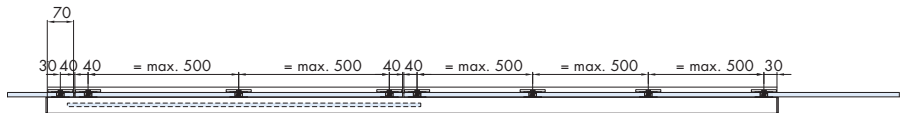
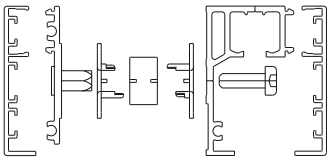

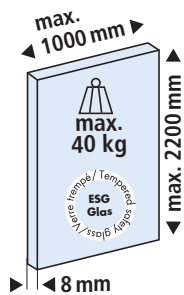
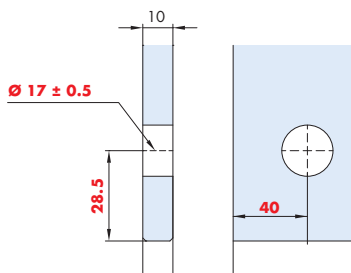

Türgewichte
Door weights
Poids de portes 39

Garnituren / Sets / Garnitures

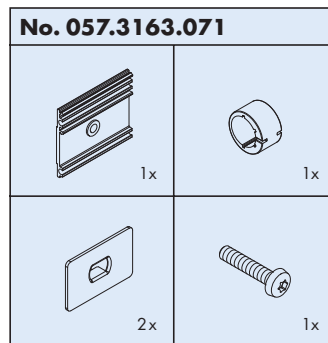

Anzahl Glasbohrungen = Mengen 057.3163.071
Number of glass drillings = quantity 057.3163.071
Nombre de perçages dans le verre = Quantités d'articles Référence 057.3163.071

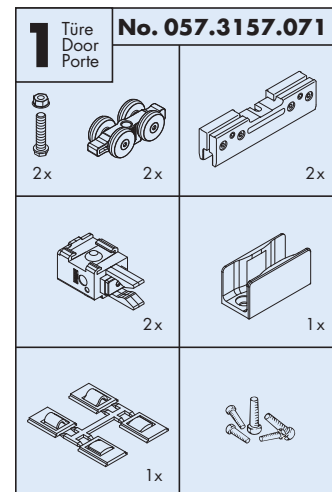

■ Eloxiert

Anodized
Anodisé

* Edelstahloptik (Albea 25.4)

Stainless steel effect (Albea 25.4)
Aspect inox (Albea 25.4)

Zubehör / Accessories / Accessoires

Laufschiene, Alu gelocht

Running track, aluminium pre-drilled
Rail de roulement, en alu perforé



Gr./Size	Art. No.
6000 mm	057.3146.600
6000 mm	057.3146.602



Clipblende zu 057.3146, Alu

Clip panel for 057.3146, aluminium
Cache à clipser pour 057.3146, en alu



6000 mm	053.3195.600
6000 mm	053.3195.602

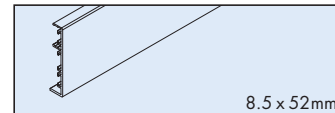

Endkappen-Set, Kunststoff anthrazit

End cap set, plastic anthracite
Jeu d'embouts, plastique anthracite

36 mm	053.3192.071
-------	--------------

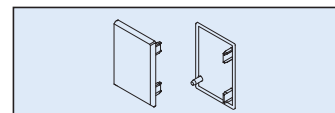

Endkappen-Set, Kunststoff anthrazit, für Glaswandmontage

End cap set, plastic anthracite, for glass wall mounting
Jeu d'embouts, plastique anthracite, pour montage mural sur vitrage

11 mm	057.3162.071
-------	--------------

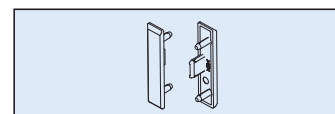

U-Führungsschiene, Alu eloxiert, gelocht

U-shaped guide track, aluminium anodized, pre-drilled
Rail de guidage U, en alu anodisé, perforé

2500 mm	057.3056.250
3500 mm	057.3056.350
6000 mm	057.3056.600

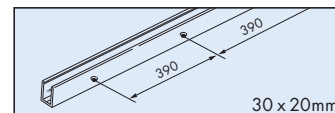

Befestigungs-Set zu 057.3056

Fixing set for 057.3056
Jeu de fixation pour 057.3056

057.3076.071

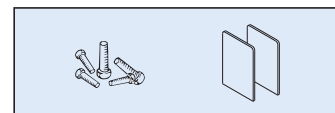

Dichtungsprofil, Kunststoff schwarz, in Rollen zu 057.3056

Sealing profile, plastic black, in coils for 057.3056
Profil d'étanchéité, plastique noire, en rouleaux pour 057.3056

20 m	057.3072.001
------	--------------

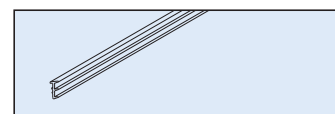

Sonderzubehör / Special accessories / Accessoires spéciaux: 36

Technische Daten / Technical data / Caractéristiques techniques: 39

Glasbearbeitung = rote Zahlen / Glass treatment = red numbers / Traitement de verre = chiffres rouges

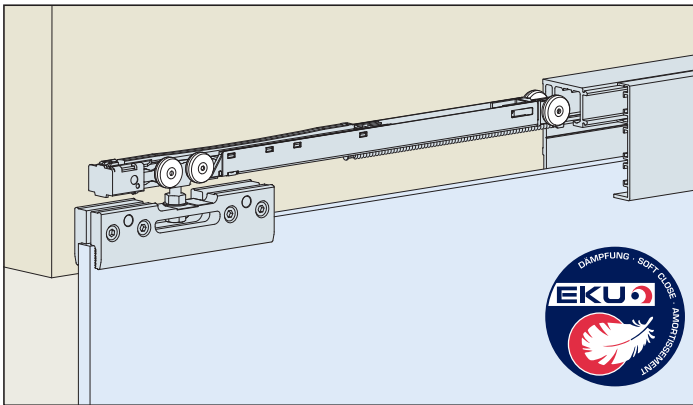

System: Dämpfungen für leisen und sanften Schiebekomfort, für 1 Glastüre bis 40 kg.

Design Dämpfung in Laufschiene integriert

System: Soft closing systems for quiet and gentle sliding convenience, for 1 glass door up to 40 kg.

Design soft closing system integrated in running track

Système: Amortissements pour un coulisement doux et pour 1 porte en verre jusqu'à 40 kg

Design Amortissement intégré au rail de roulement

Empfehlung: Der Zugang zu den Dämpfungskomponenten sollte jederzeit möglich sein.

Demontierbare Laufschienen planen.

Recommendation: The access to the components of the soft closing mechanism should be possible at any time.

Plan removable running tracks.



Recommandation: l'accès aux composants de l'amortissement doit être possible à tout moment.

Prévoir en conséquence des rails de roulement démontables.

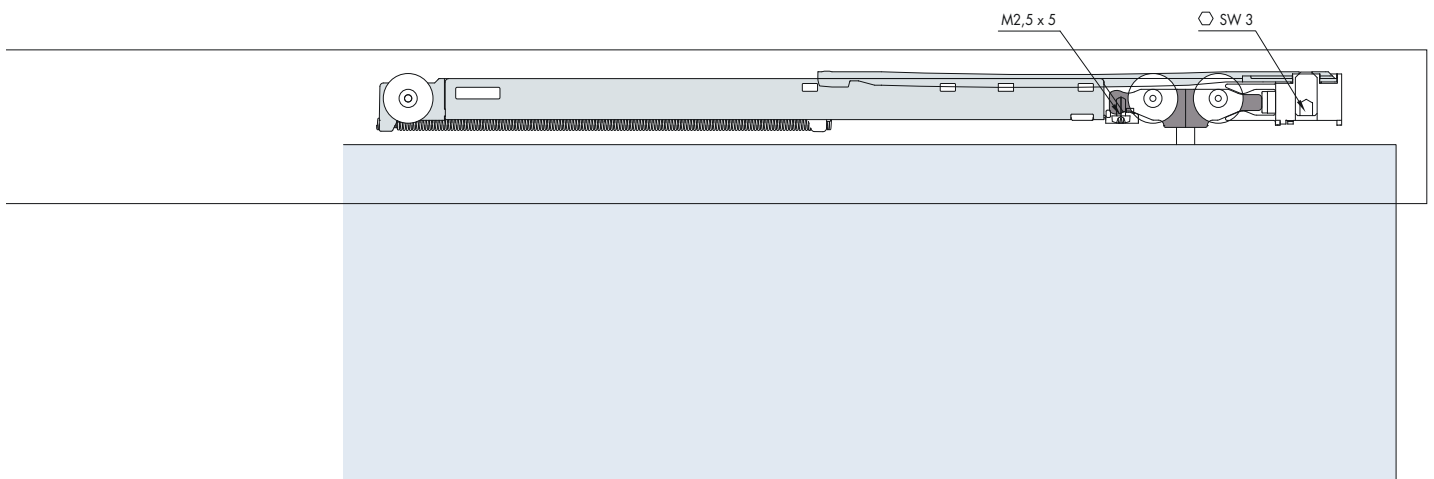
Einbaubeispiele / Mounting examples / Exemples de montage

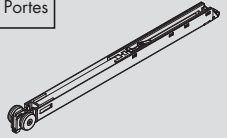
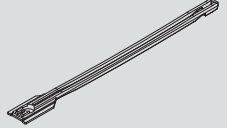

Garnituren / Sets / Garnitures

1 Türen Doors Portes	No. 057.3159.073	
		
	2x	
		
2x		
		
2x		

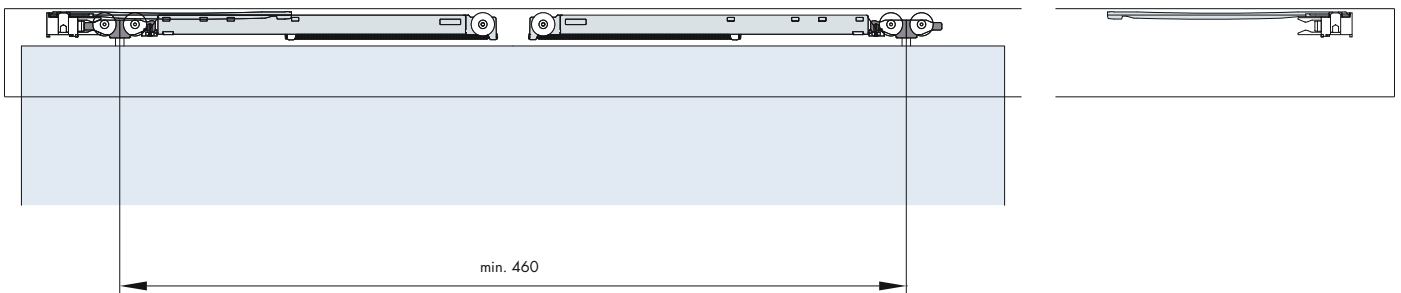



GW/GWF



G



GU

EKU-PORTA 100 G-Synchro

EKU-PORTA 100 GF



GFO



GM



GMD

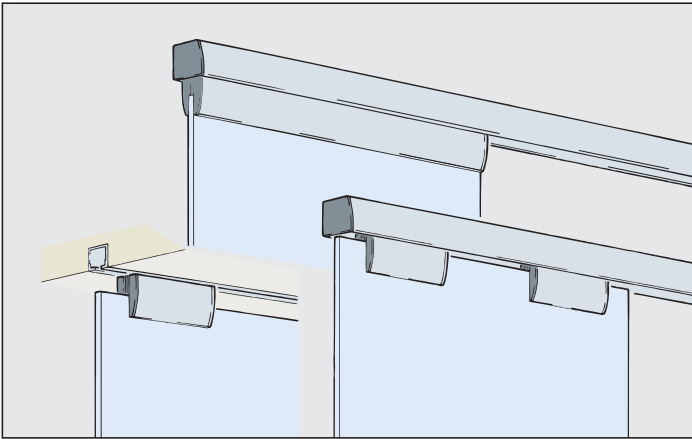

Design-Blenden zu Laufschiene und Klemmschuh

Design panels for running track and clamping shoe
Caches design pour rail de roulement et mâchoire de serrage

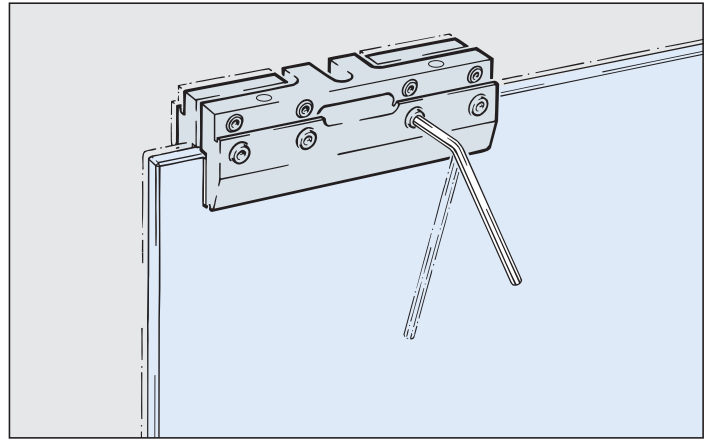

Klemmen ohne Glasbearbeitung (8-12.7 mm Glas)

Clamping without machining of the glass (8-12.7 mm glass)
Serrage sans usinage du verre (verre de 8-12.7 mm)

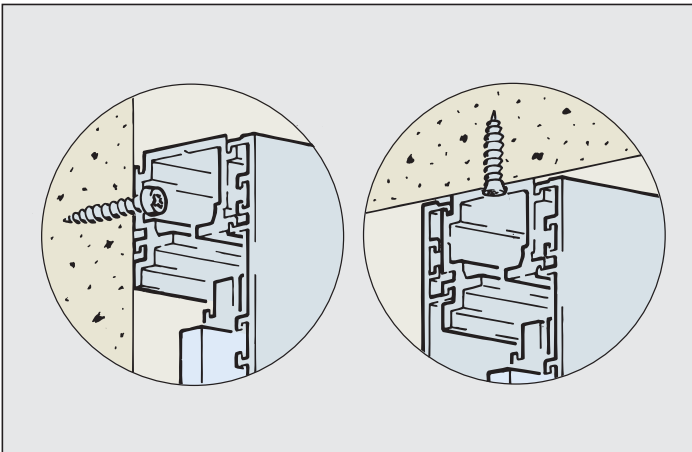

Combi-Laufschiene für Wand- oder Deckenmontage

Combi running track for wall or ceiling mounting
Rail de roulement pour montage mural ou au plafond

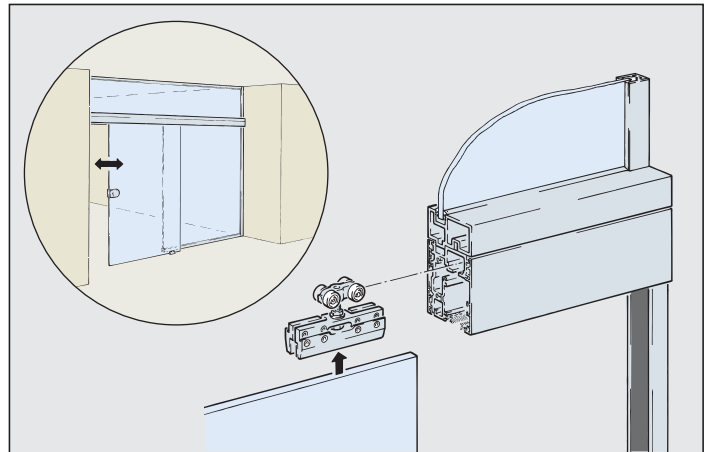

System Einbau in der Lichte mit Oberlicht-Trockenverglasung

System freespan installation with glass transom-dry glazing
Système de vitrage pour le montage entre parois avec imposte

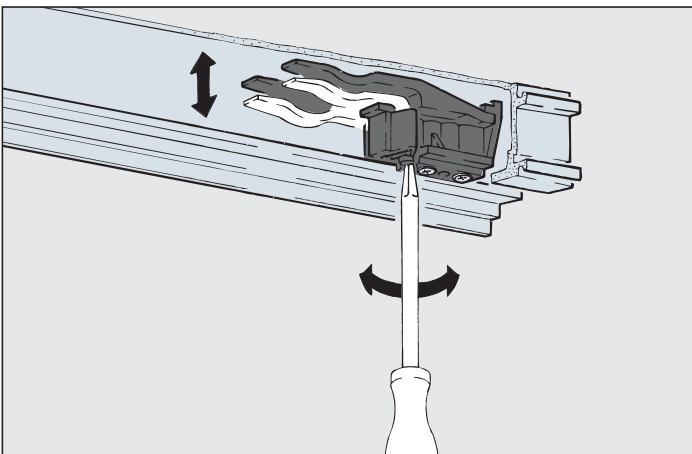

Stufenlos einstellbare Arretierkraft

Variably adjustable retention spring
Réglage en continu de la force de blocage

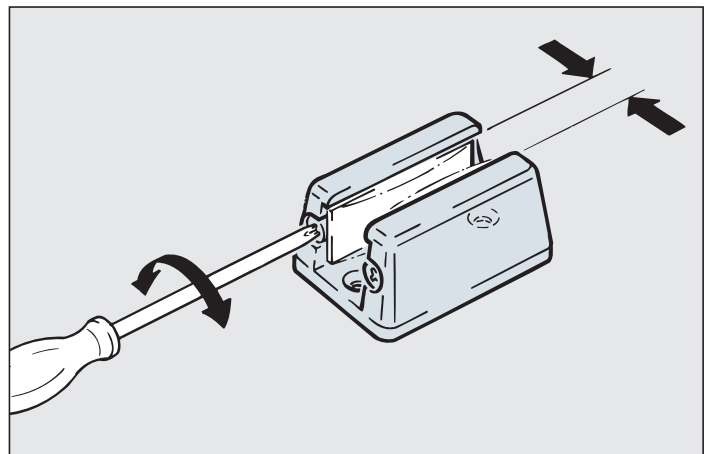

Spielfreie Bodenführung (6-12.7 mm Glas)

Playfree bottom guide (6-12.7 mm glass)
Guidage au sol sans jeu (verre 6-12.7 mm)

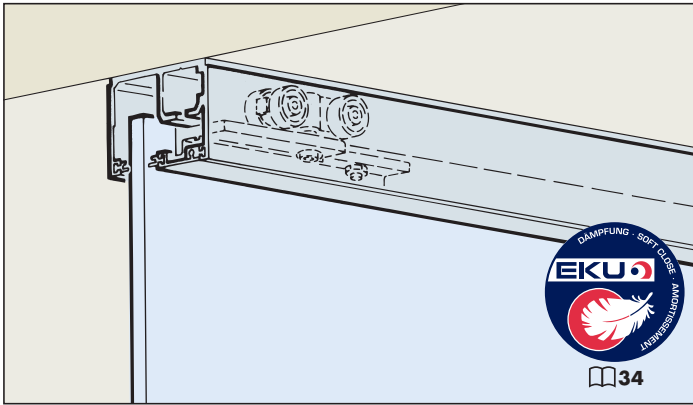

System: Laufschiene, Einbauhöhe 58 mm, einsetzbar bei aufgesetzter oder deckenbündiger Anwendung, für 1 Glastüre bis 100 kg.

System: Running track, installation height 58 mm, surface mounted or flush with the ceiling, for 1 glass door up 100 kg.

Système: Rail de roulement, hauteur d'installation 58 mm, montage en applique ou affleurant avec le plafond, pour 1 porte en verre jusqu'à 100 kg.

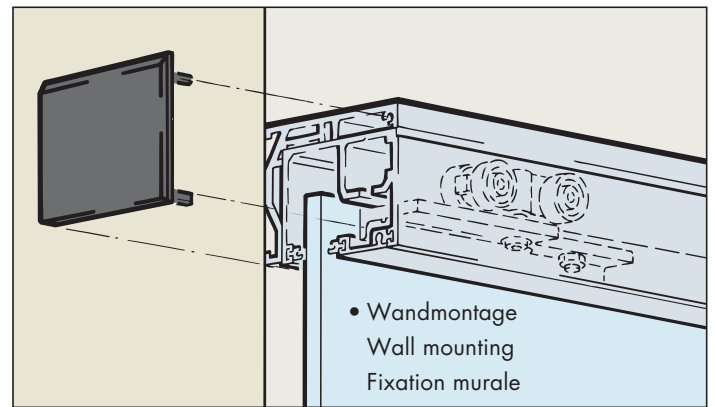
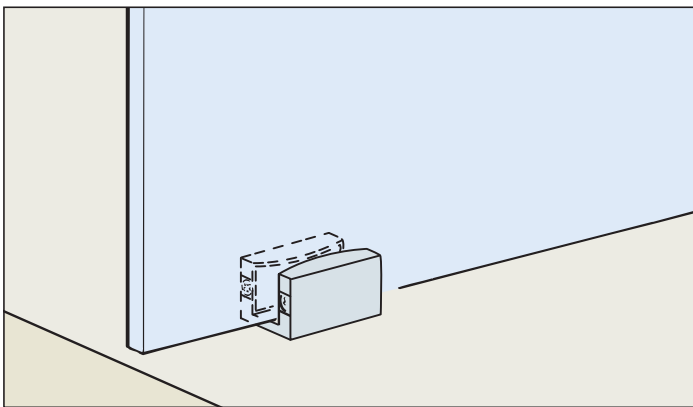

Einbaubeispiele / Mounting examples / Exemples de montage

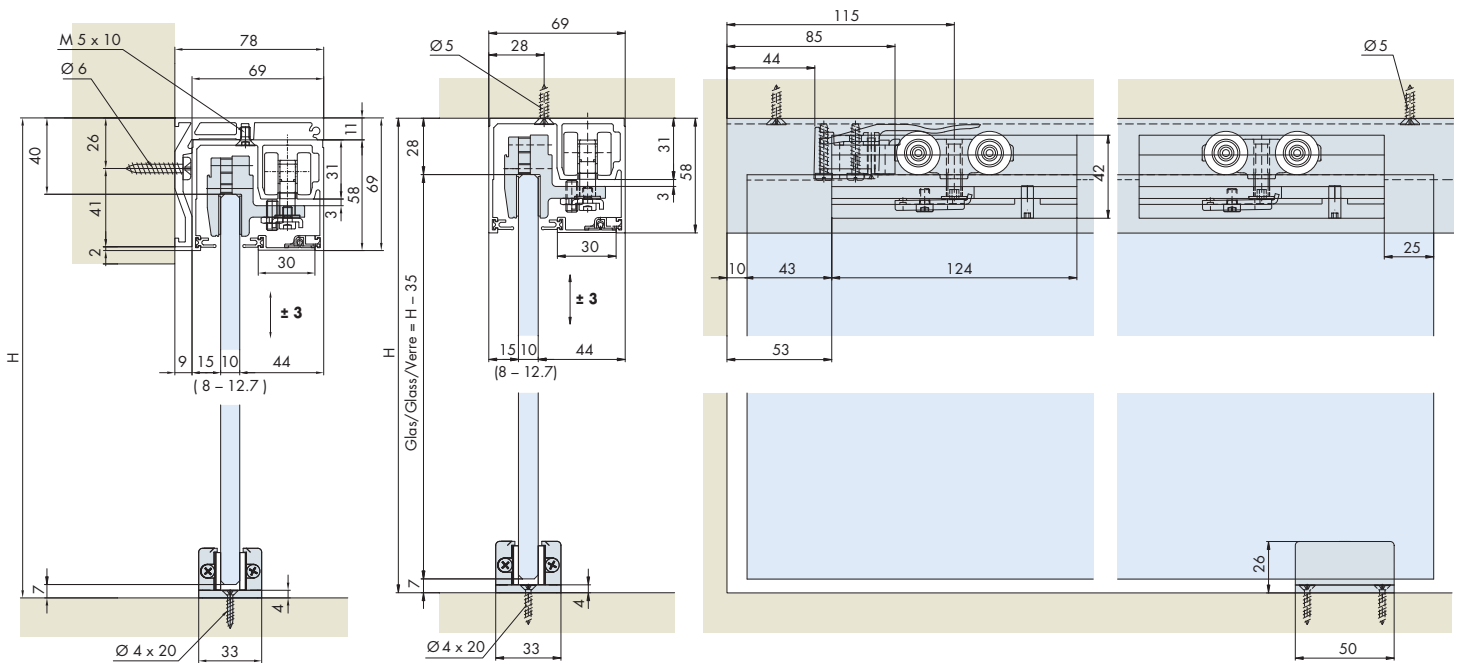

Einbaubeispiel deckenbündige Montage

Mounting example flush with the ceiling

Exemple de montage affleurant avec le plafond

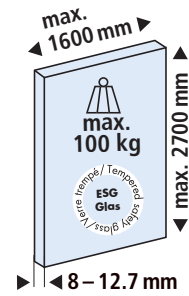
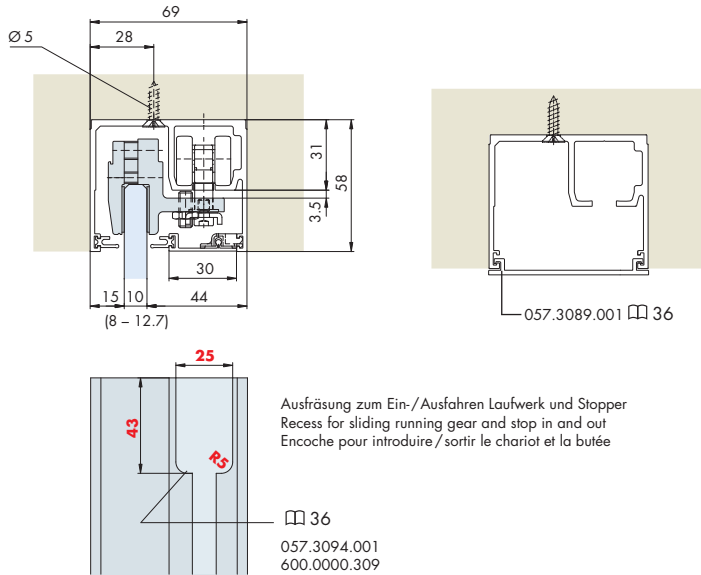

Türgewichte
Door weights
Poids de portes 39

Garnituren / Sets / Garnitures

1 Türe Door Porte		No. 057.3091.071	
2x	2x	2x	
1x	1x	1x	
1x	12x		
1x			

Zubehör / Accessories / Accessoires

Laufschiene, Alu eloxiert, gelocht

Running track, aluminium anodized, pre-drilled
Rail de roulement, en alu anodisé, perforé

Gr./Size	Art. No.
2500 mm	057.3083.250
3500 mm	057.3083.350
6000 mm	057.3083.600

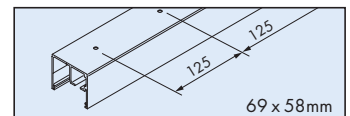

Endkappen-Set zu 057.3083, Kunststoff anthrazit

End cap set for 057.3083, plastic anthracite
Jeu d'embouts pour 057.3083, plastique anthracite

057.3118.071

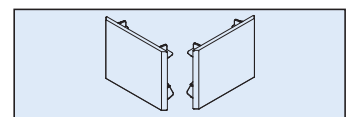

Blendenprofil, Alu eloxiert

Panel profile, aluminium anodized
Profil de cache, en alu anodisé

2500 mm	057.3085.250
3500 mm	057.3085.350
6000 mm	057.3085.600



• Sichtschutzdichtung, Kunststoff schwarz, in Rollen

Screening seal, black plastic, in rolls
Joint pare-vue, plastique noir, en rouleaux

20 m 057.3078.002

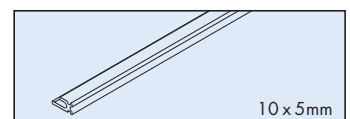

• Wandbefestigungs-Winkelprofil, Alu eloxiert, gelocht

Wall mounting angle profile, aluminium anodized, pre-drilled
Profil en équerre pour fixation murale, alu anodisé, perforé

2500 mm 057.3100.250

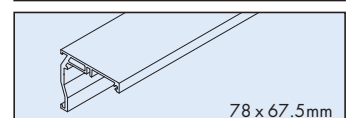

• Endkappen-Set zu 057.3100, Kunststoff anthrazit, mit Schrauben für Schienen bis 2500 mm

End cap set for 057.3100, plastic anthracite, incl. screws for tracks up to 2500 mm
Jeu d'embouts pour 057.3100, plastique anthracite, incl. vis pour rail jusqu'à 2500 mm

057.3103.071

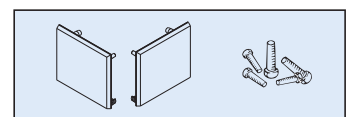

• Schrauben-Set zu 057.3100 > 2500 mm

Screw set for 057.3100 > 2500 mm
Jeu de vis pour 057.3100 > 2500 mm

12x 057.3102.071

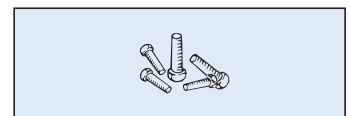

Schienenbearbeitung = rote Zahlen / Dimensions and drillings for profile = red numbers / Traitement de profil = chiffres rouges

• Optionale Wandmontage / Wall mounting optional / Fixation murale facultative

Sonderzubehör / Special accessories / Accessoires spéciaux: 36

Technische Daten / Technical data / Caractéristiques techniques: 39

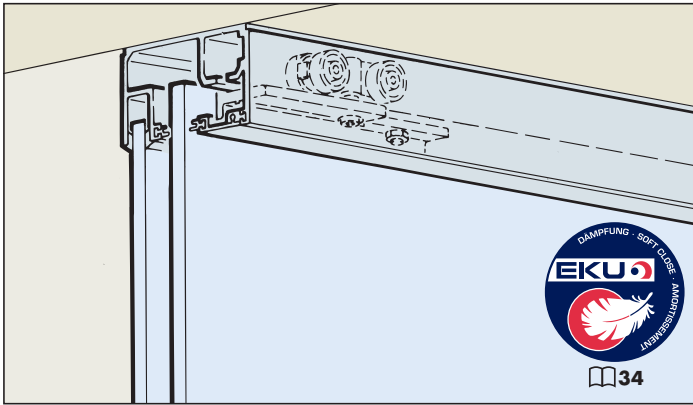

System: Laufschiene mit Festglashalterung, Einbauhöhe 58 mm, einsetzbar bei aufgesetzter oder deckenbündiger Anwendung, für 1 Glastüre bis 100 kg.

System: Running track with fixed glass support profile, installation height 58 mm, surface mounted or flush with the ceiling, for 1 glass door up to 100 kg.

Système: Rail de roulement avec porte-vitre fixe, hauteur d'installation 58 mm, montage en applique ou affleurant avec le plafond, pour 1 porte en verre jusqu'à 100 kg.

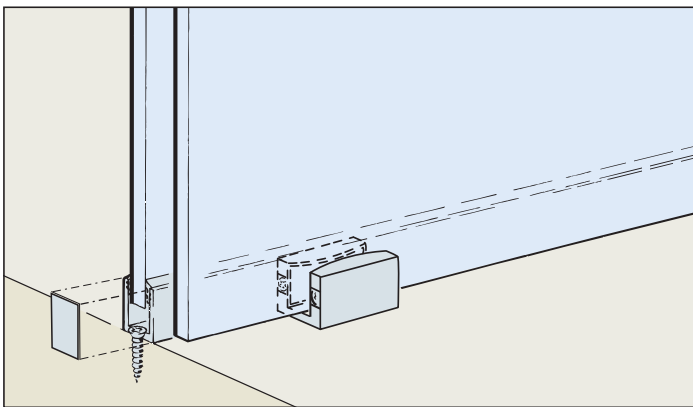

Einbaubeispiele / Mounting examples / Exemples de montage

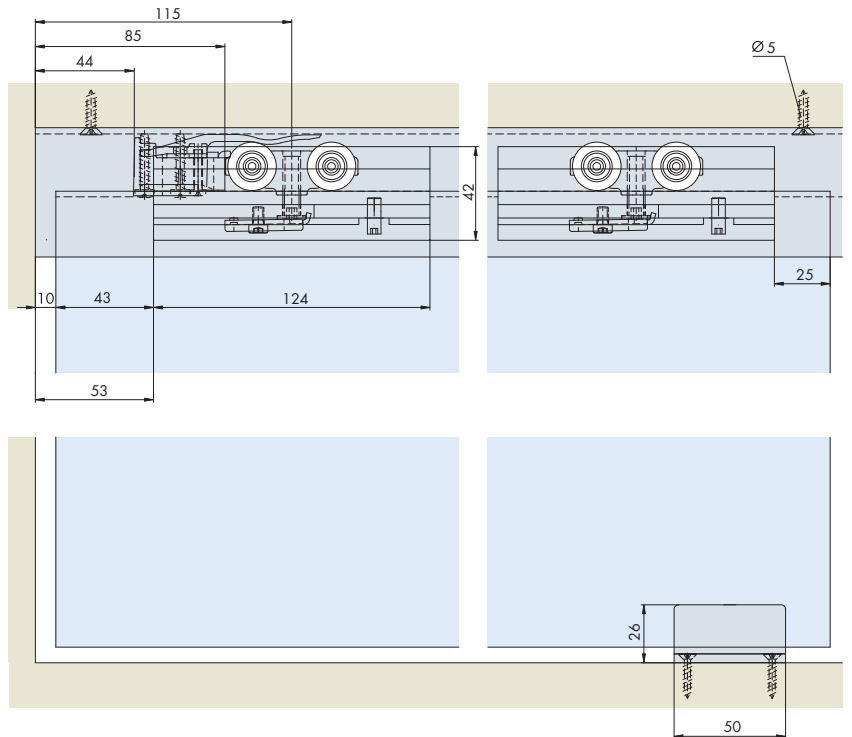
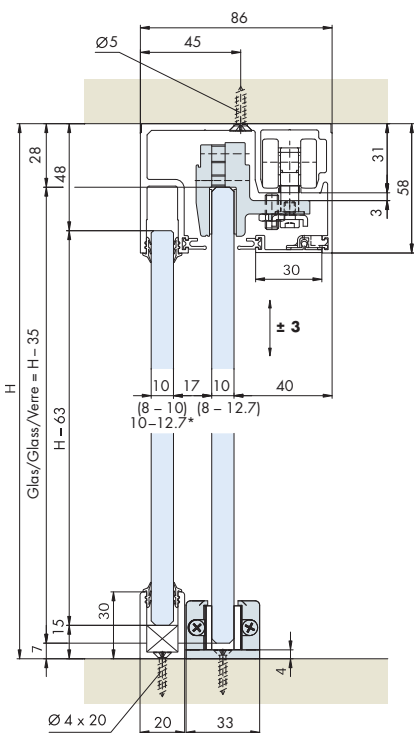

* 10-12.7 mm Glas, Nassversiegelung mit Silikon
 10-12.7 mm glass, wet caulking with silicone
 10-12.7 mm verre scellage au mouillé avec silicone
 Art. No. 098.0027.000 □ 36





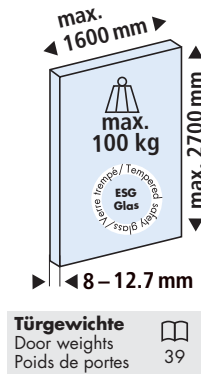
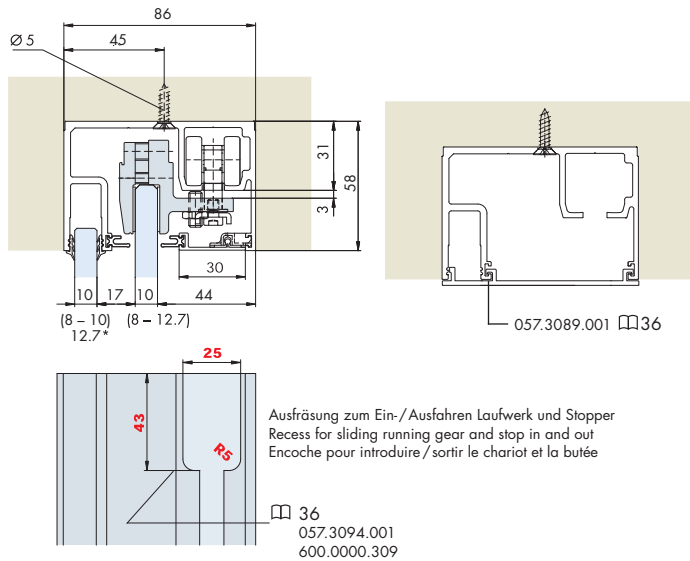

Einbaubeispiel deckenbündig

Mounting example flush with the ceiling

Exemple de montage affleurant avec le plafond

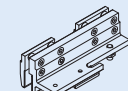
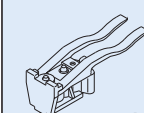
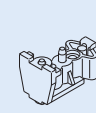
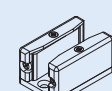

Garnituren / Sets / Garnitures

1 Türe Door Porte		No. 057.3091.071	
 2x	 2x	 2x	
 1x	 1x		
 1x	 12x		
 1x			

Zubehör / Accessories / Accessoires

Laufschiene Festglas, Alu eloxiert, gelocht

Running track fixed glass, aluminium anodized, pre-drilled
Rail de roulement vitre fixe, en alu anodisé, perforé

Gr./Size	Art. No.
2500 mm	057.3084.250
3500 mm	057.3084.350
6000 mm	057.3084.600

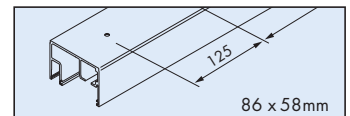

Blendenprofil, Alu eloxiert

Panel profile, aluminium anodized
Profil de cache, en alu anodisé

2500 mm	057.3085.250
3500 mm	057.3085.350
6000 mm	057.3085.600



Stirnprofil, Alu eloxiert, zu 057.3084

Front edge profile, aluminium anodized, for 057.3084
Profil à l'avant, en alu anodisé, pour 057.3084

2500 mm	042.3005.250
3000 mm	042.3005.300
6000 mm	042.3005.600

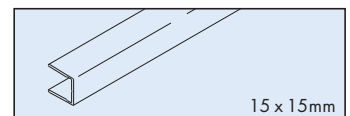

U-Führungsschiene, Alu eloxiert, gelocht

U-shaped guide track, aluminium anodized, pre-drilled
Rail de guidage en U, en alu anodisé, perforé

2500 mm	057.3056.250
3500 mm	057.3056.350
6000 mm	057.3056.600

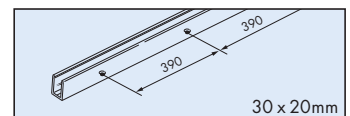

Befestigungs-Set zu 057.3056

Fixing set for 057.3056
Jeu de fixation pour 057.3056

057.3076.071

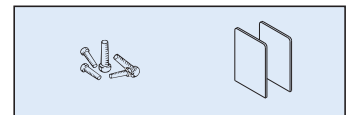

Dichtungsprofil, Kunststoff schwarz, in Rollen

Sealing profile, plastic black, in coils
Profil d'étanchéité, plastique noir, en rouleaux

20 m 057.3072.001

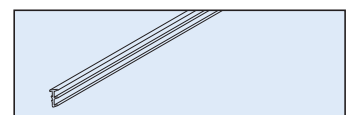

Sichtschutzdichtung, Kunststoff schwarz, in Rollen

Screening seal, plastic black, in coils
Joint pare-vue, plastique noir, en rouleaux

20 m 057.3078.002

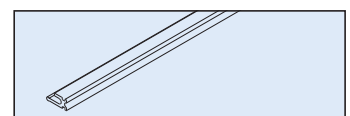

Schienenbearbeitung = rote Zahlen / Dimensions and drillings for profile = red numbers / Traitement de profil = chiffres rouges

Sonderzubehör / Special accessories / Accessoires spéciaux: 36

Technische Daten / Technical data / Caractéristiques techniques: 39

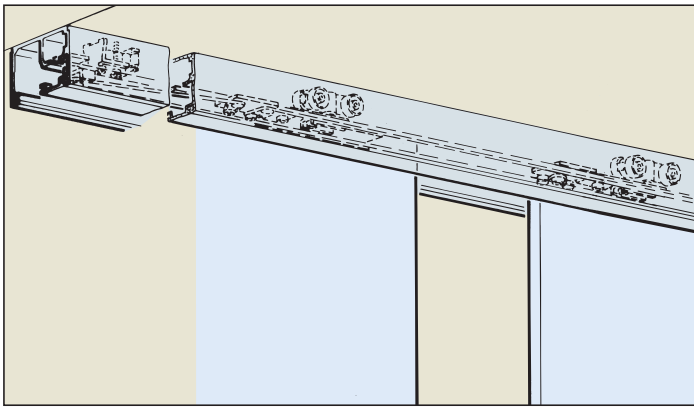

System: Synchro für 2 synchronlaufende Glastüren mit Kevlarseil zu EKU-PORTA 100 GW/GWF

System: Synchro for 2 synchronized running glass doors with kevlarseil for EKU-PORTA 100 GW/GWF

Système: Synchro pour 2 portes en verre à roulement synchronisé avec âble kevlar pour EKU-PORTA 100 GW/GWF

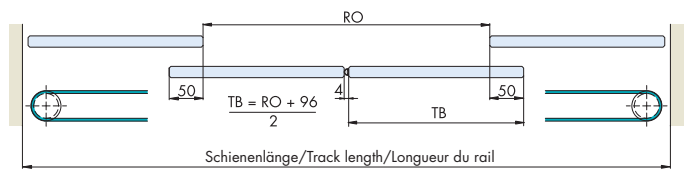
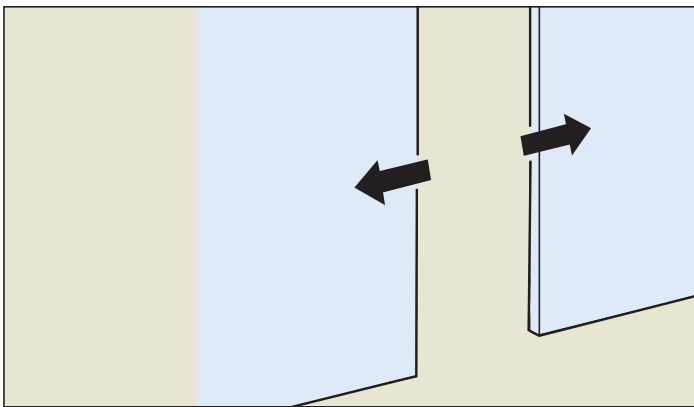

Einbaubeispiele / Mounting examples / Exemples de montage

EKU-PORTA 100 GW

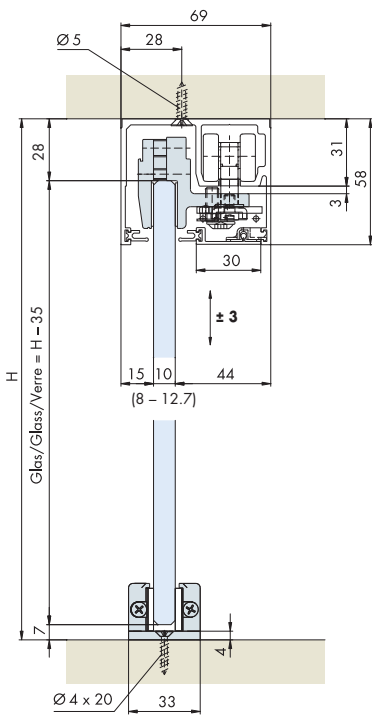

EKU-PORTA 100 GWF

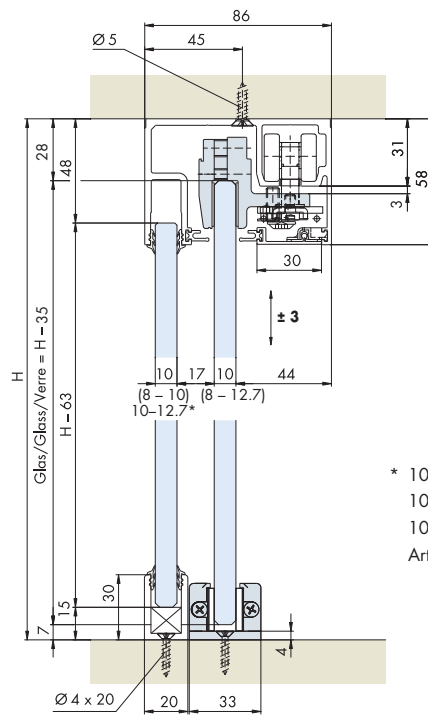

* 10-12.7 mm Glas, Nassversiegelung mit Silikon
 10-12.7 mm glass, wet caulking with silicone
 10-12.7 mm verre scellage au mouillé avec silicone
 Art. No. 098.0027.000 □36

Einbaubeispiel deckenbündig

Mounting example flush with the ceiling

Exemple de montage affleurant avec le plafond

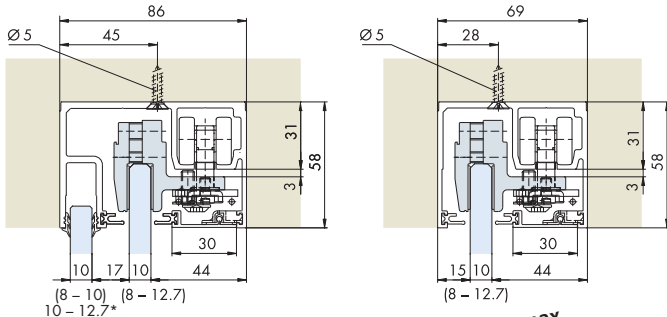

(8 - 10) (8 - 12.7)
10 - 12.7*

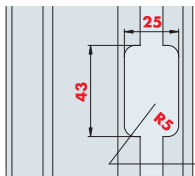
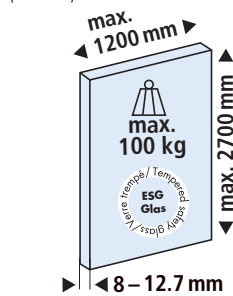

36
057.3094.001
600.0000.309

Ausrüstung zum Ein-/Ausfahren Laufwerk und Stopper in der Mitte der Laufschiene
Recess for sliding running gear and stop in and out in the center of the running track
Encoche pour introduire/sortir le chariot et la butée au milieu du rail de roulement

Garnituren / Sets / Garnitures

1 Türe Door Porte	No. 057.3091.071	
	2x	2x
	1x	1x
	1x	12x
	1x	2x
Bitte 2 Garnituren bestellen Please order 2 sets A commander 2 garnitures		

2 Türen Doors Portes	No. 057.3092.071	
	1x	1x
	10 m	2x
	2.70 m	2x

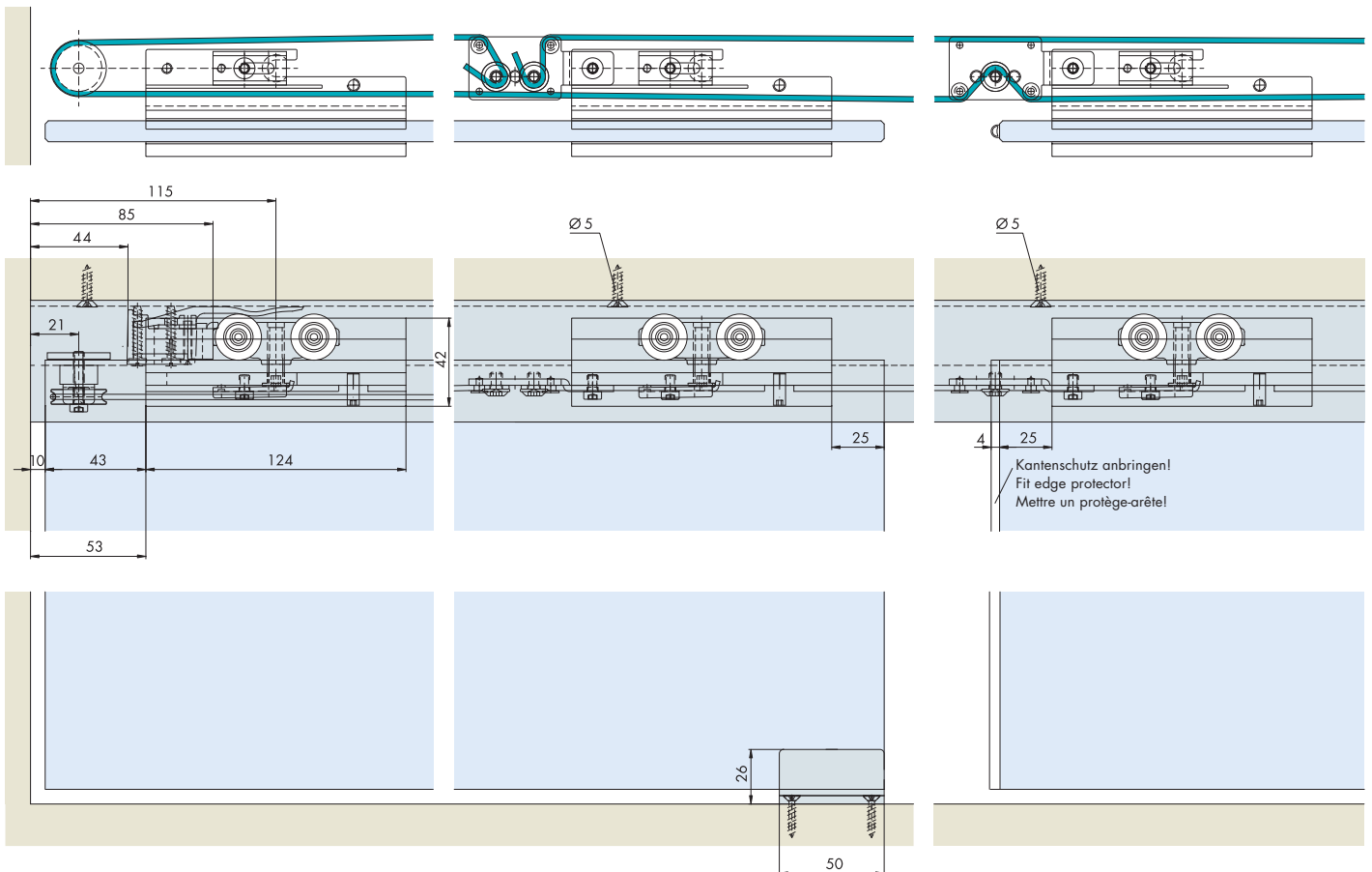

Schienebearbeitung = rote Zahlen / Dimensions and drillings for profile = red numbers / Traitement de profil = chiffres rouges

Technische Daten / Technical data / Caractéristiques techniques: 39

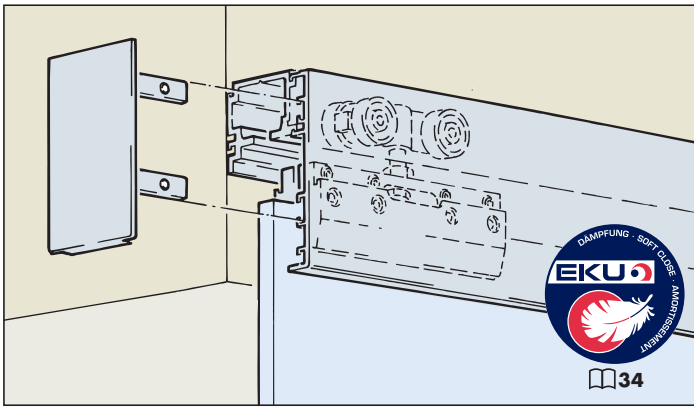

System: Combi-Laufschiene für Wand- oder Deckenmontage, für 1 Glastüre bis 100kg. Design Clip-Blende Alu oder Holz

System: Combi running track for wall or ceiling mounting, for 1 glass panel up to 100 kg.
Design Aluminium or wood clip panel

Système: Rail de roulement Combi pour montage mural ou au plafond, pour 1 porte en verre jusqu'à 100 kg.
Design Cache à clipser en alu ou en bois

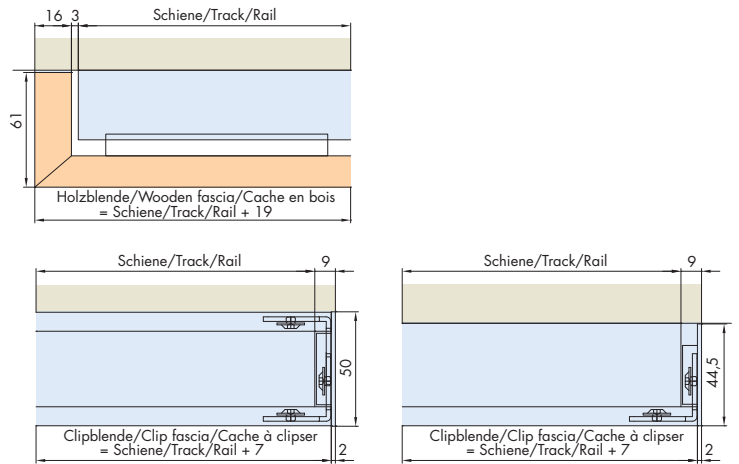
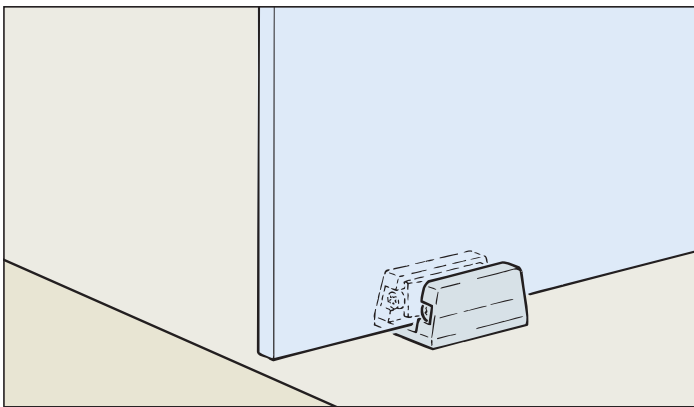

Einbaubeispiele / Mounting examples / Exemples de montage

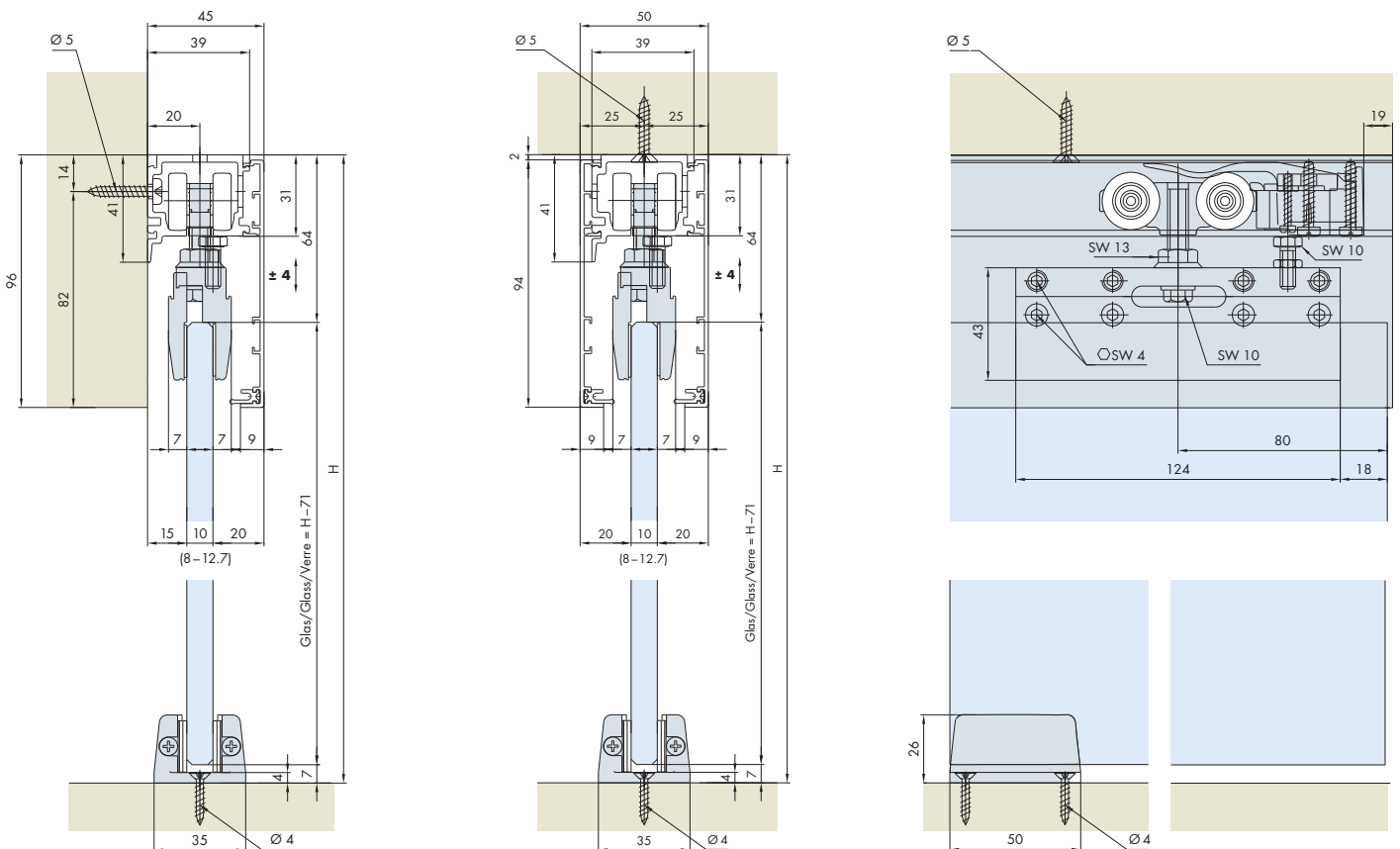

Einbauvarianten mit Holzblende

Mounting versions with wooden panel / Variantes de montage avec cache en bois

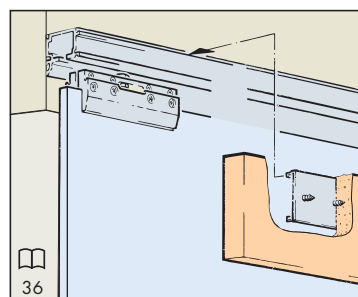
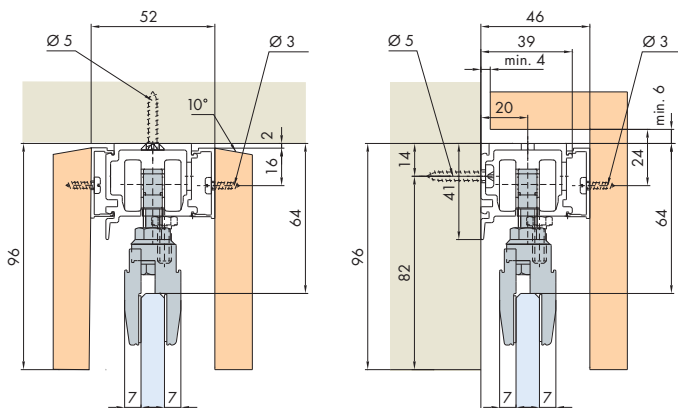

Befestigungsabstand für Clip-Teil alle 500mm

Fixing distance for clip component every 500mm
Distance des clips tous les 500mm

36

Garnituren / Sets / Garnitures



Türgewichte
Door weights
Poids de portes 39

1 Türe Door Porte		No. 057.3074.071	
2x	2x	2x	2x
1x	1x	1x	1x
1x	1x	1x	1x

Zubehör / Accessories / Accessoires

Combi-Laufschiene, Alu gelocht

Combi running track, aluminium pre-drilled
Rail de roulement, en alu perforé

Gr./Size	Art. No.
1700 mm	057.3048.170
2000 mm	057.3048.200
2500 mm	057.3048.250
3500 mm	057.3048.350
6000 mm	057.3048.600

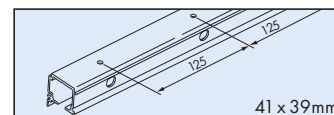

Clip-Blende zu Laufschiene, Alu eloxiert

Clip panel for running track, aluminium anodized
Cache à clipser pour rail de roulement, en alu anodisé

2500 mm	057.3050.250
3500 mm	057.3050.350
6000 mm	057.3050.600

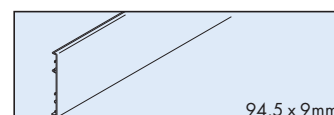

Blendenendstück-Set, Alu eloxiert, einseitig, Wandmontage

Panel end component set, aluminium anodized, one-sided, wall mounting
Jeu d'extrémités de cache, en alu anodisé, un côté, montage mural

44.5 mm	057.3052.074
---------	--------------

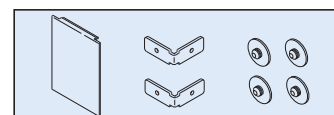

Blendenendstück-Set, Alu eloxiert, einseitig, Deckenmontage

Panel end component set, aluminium anodized, one-sided, ceiling mounting
Jeu d'extrémités de cache, en alu anodisé, un côté, montage au plafond

50.0 mm	057.3052.071
---------	--------------

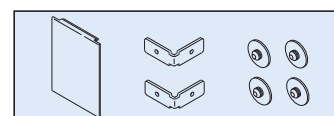

Sichtschutzdichtung, Kunststoff schwarz, in Rollen

Screening seal, plastic black, in coils
Joint pare-vue, plastique noir, en rouleaux

20 m	057.3078.002
------	--------------

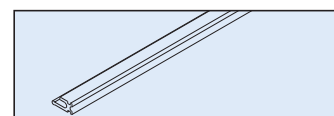

Sonderzubehör / Special accessories / Accessoires spéciaux: 36

Technische Daten / Technical data / Caractéristiques techniques: 39

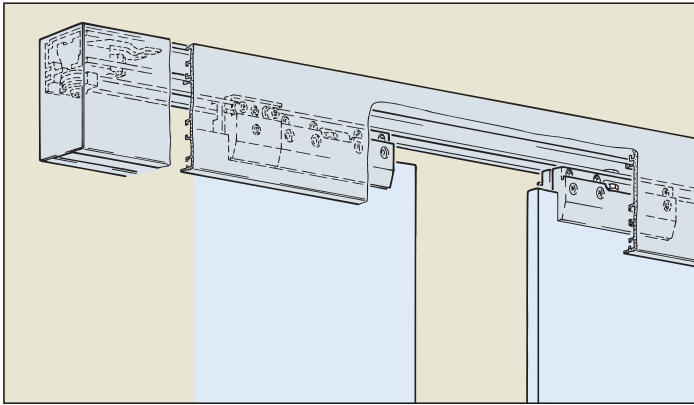

Systemzusatz: Synchro für 2 synchronlaufende Glastüren mit Kevlarseil zu EKU-PORTA 100 G/GF/GFO

System addition: Synchro for 2 synchronized running glass panels with kevlar rope for EKU-PORTA 100 G/GF/GFO

Supplément de système: Synchro pour 2 portes en verre synchronisées avec câble kevlar pour EKU-PORTA 100 G/GF/GFO

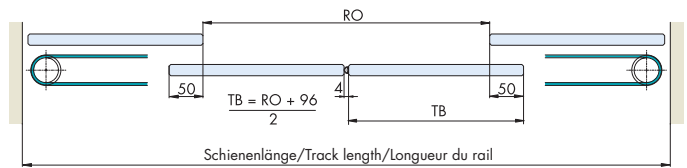
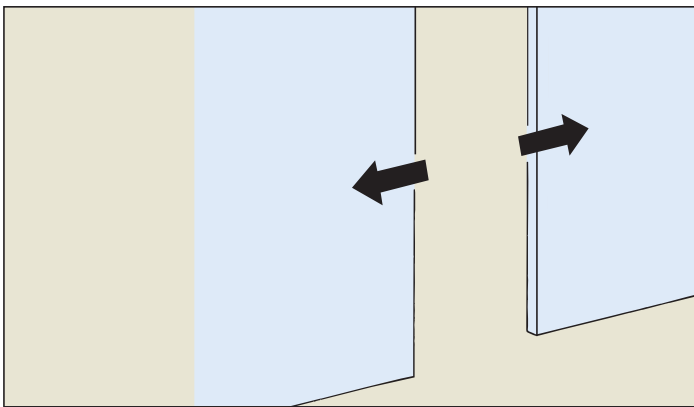

Einbaubeispiele / Mounting examples / Exemples de montage

EKU-PORTA 100 G

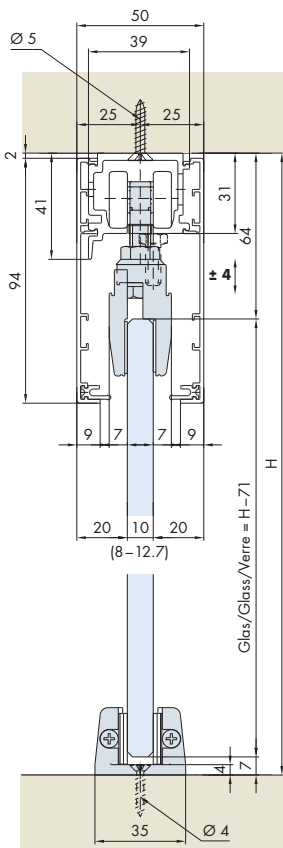



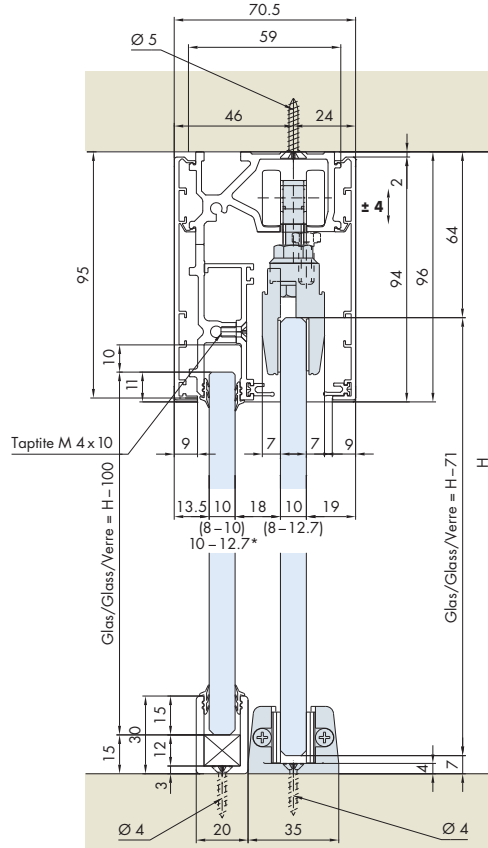





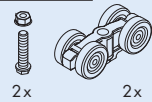
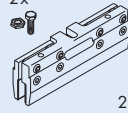
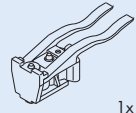

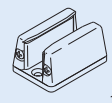
EKU-PORTA 100 GF

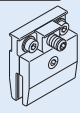

* 10-12.7 mm Glas, Nassversiegelung mit Silikon
 10-12.7 mm glass, wet caulking with silicone
 10-12.7 mm verre scellage au mouillé avec silicone
 Art. No. 098.0027.000 □ 36

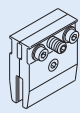
Garnituren / Sets / Garnitures

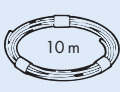
<p>1 Türe Door Porte</p>  <p>2x 2x</p>	<p>No. 057.3074.071</p> <p>2x</p>  <p>2x</p>	
	 <p>1x</p>	 <p>1x</p>
	 <p>1x</p>	 <p>1x</p>
	 <p>Bitte 2 Garnituren bestellen Please order 2 sets A commander 2 garnitures</p>	

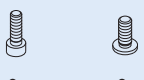
<p>2 Türen Doors Portes</p>  <p>1x</p>	<p>No. 057.3075.071</p>  <p>2x</p>	
	 <p>1x</p>	 <p>2x</p>
	 <p>1x</p>	 <p>2x</p>
	 <p>2.70 m</p>	 <p>2x 2x</p>



Türgewichte
Door weights
Poids de portes



39

Schienenlänge / Track length / Longueur du rail $S = (2 \times RO) + 80$

Rahmenöffnung / Frame opening / Ouverture du cadre = RO

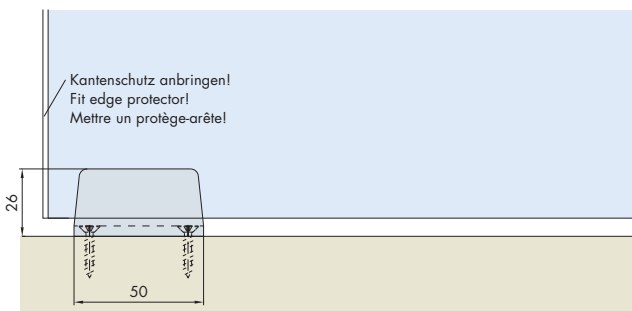
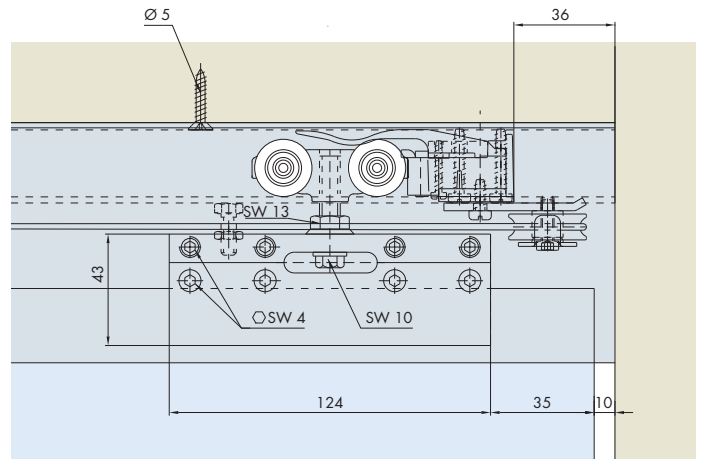
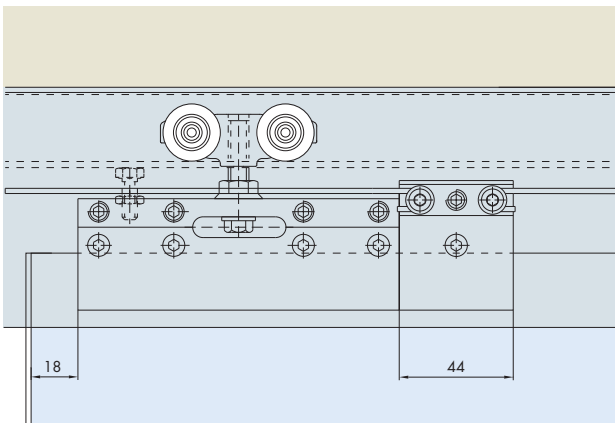
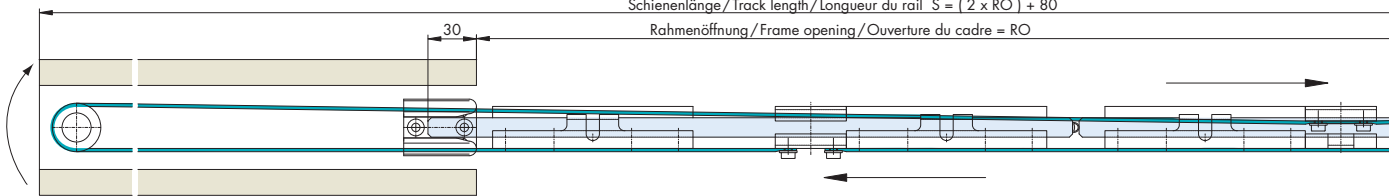

Sonderzubehör / Special accessories / Accessoires spéciaux: 36

Technische Daten / Technical data / Caractéristiques techniques: 39

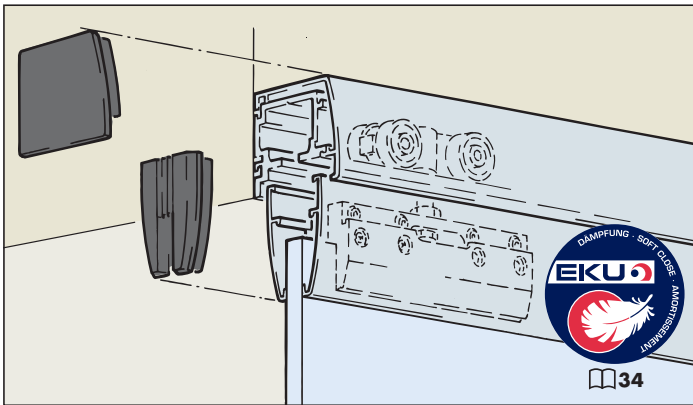

System: Combi-Laufschiene, Wandmontage, für 1 Glastüre bis 100kg.

Design Alu-Blenden zu Laufschiene und Klemmschuh

System: Combi running track, wall-mounting, for 1 glass door up to 100kg.

Design Aluminium panels for running track and clamping shoe

Système: Rail de roulement Combi de combinaison, montage mural, pour 1 porte en verre jusqu'à 100kg.

Design Caches en alu pour rail de roulement et mâchoire de serrage

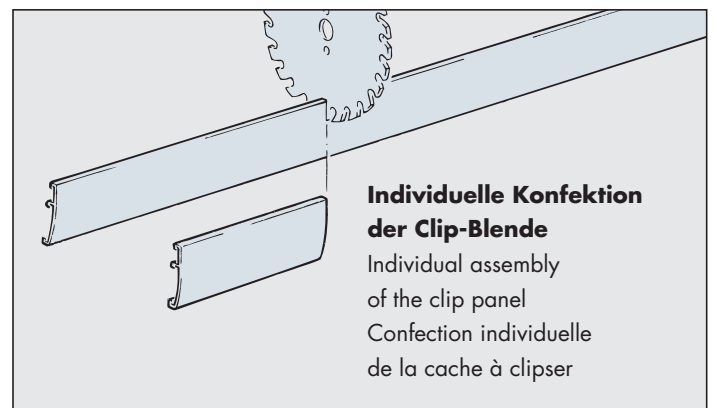
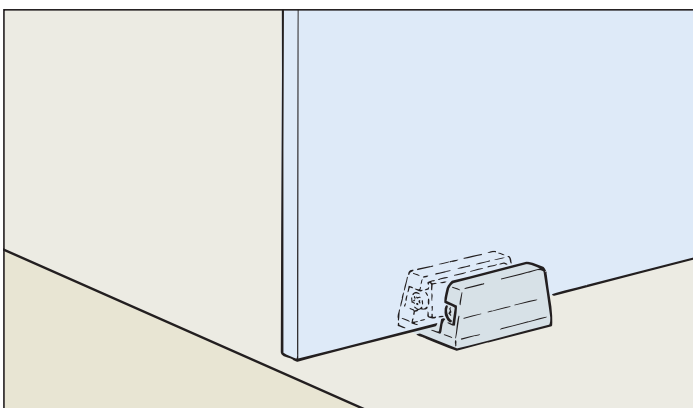

Einbaubeispiele / Mounting examples / Exemples de montage

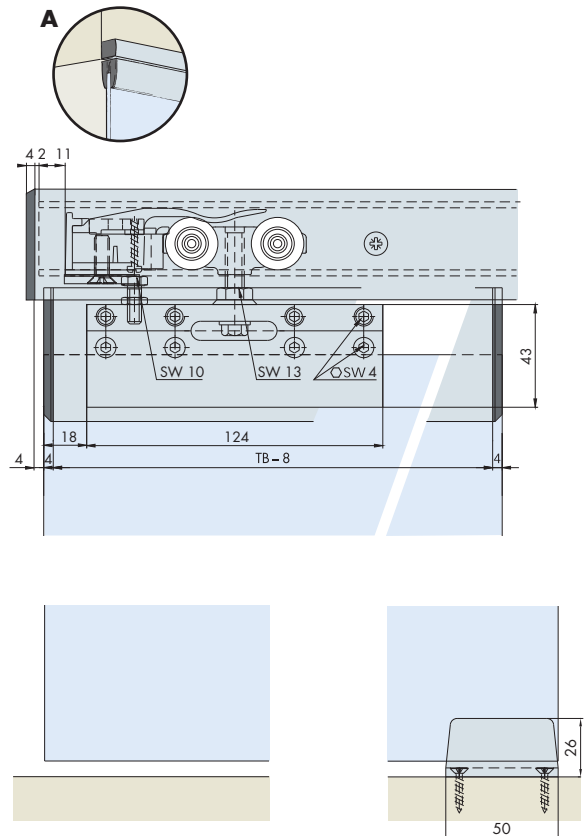
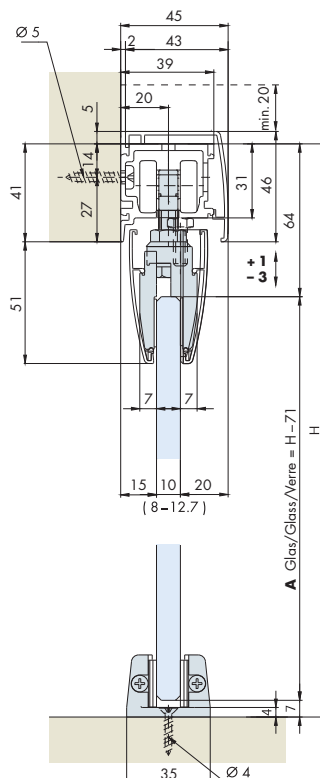
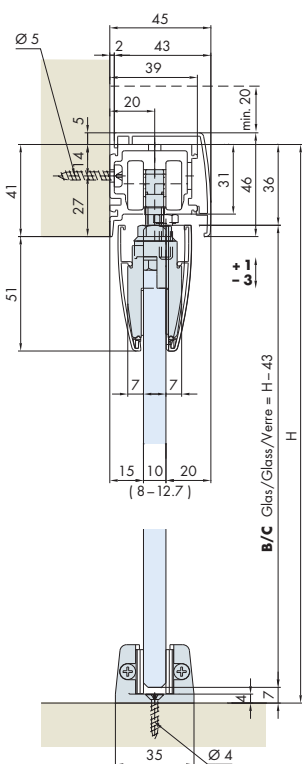

Einbaubeispiele mit Glasbearbeitung

Mounting examples with machining of the glass

Exemples de montage avec usinage du verre

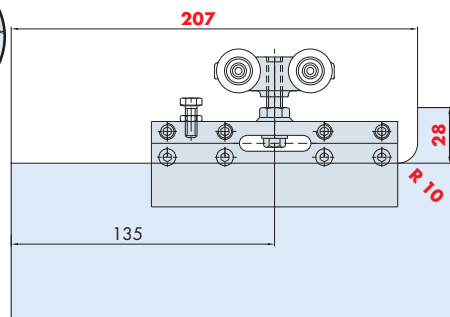
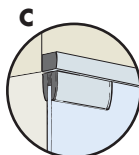
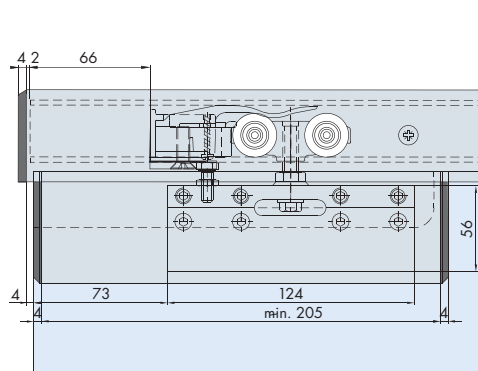
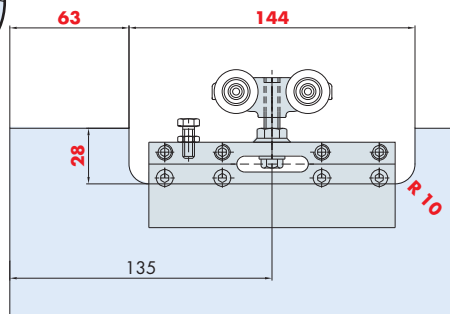
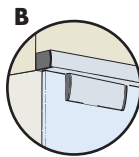
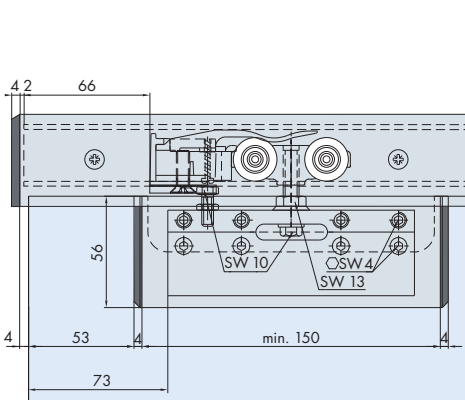

Garnituren / Sets / Garnitures

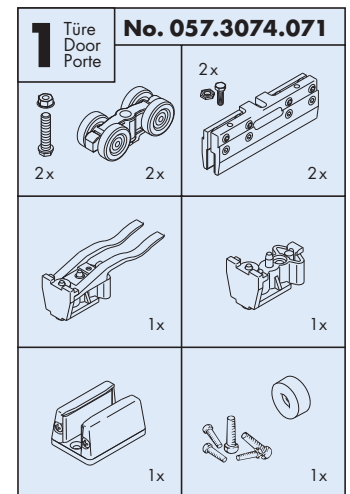

Zubehör / Accessories / Accessoires

Combi-Laufschiene, Alu gelocht

Combi running track, aluminium pre-drilled

Rail de roulement, en alu perforé

Gr./Size	Art. No.
1700 mm	057.3048.170
2000 mm	057.3048.200
2500 mm	057.3048.250
3500 mm	057.3048.350
6000 mm	057.3048.600

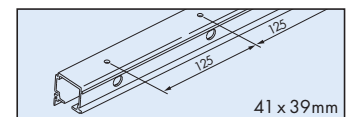

Design-Blende, Alu eloxiert, zu Combi-Laufschiene

Clip panel, aluminium anodized, for combi running track

Cache design, en alu anodisé, pour rail de roulement

2500 mm	057.3070.250
6000 mm	057.3070.600

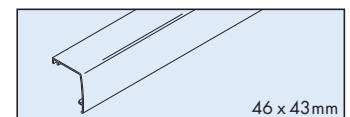

Clip-Blende zu Klemmschuh, Alu eloxiert

Clip panel for clamp shoe, aluminium anodized

Cache à clipser pour mâchoire de serrage, en alu anodisé

2500 mm	057.3039.250
6000 mm	057.3039.600

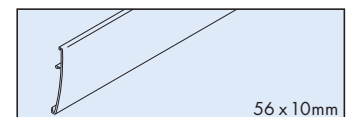

Endkappen-Set zu Blenden, Kunststoff anthrazit

End cap set for panels, plastic anthracite

Jeu d'embouts pour caches, plastique anthracite

057.3061.071

A
B/C

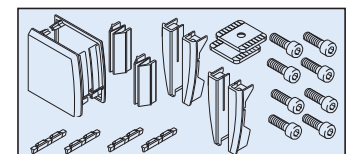

Endkappen-Set zu Blenden, Kunststoff anthrazit

End cap set for panels, plastic anthracite

Jeu d'embouts pour caches, plastique anthracite

057.3061.072

B/C

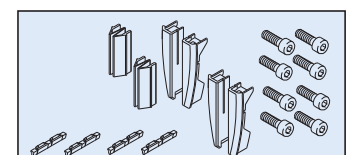

Türbearbeitung = rote Zahlen / Dimensions and drillings for door = red numbers / Traitement de portes = chiffres rouges

Sonderzubehör / Special accessories / Accessoires spéciaux: ☞ 36

Technische Daten / Technical data / Caractéristiques techniques: ☞ 39

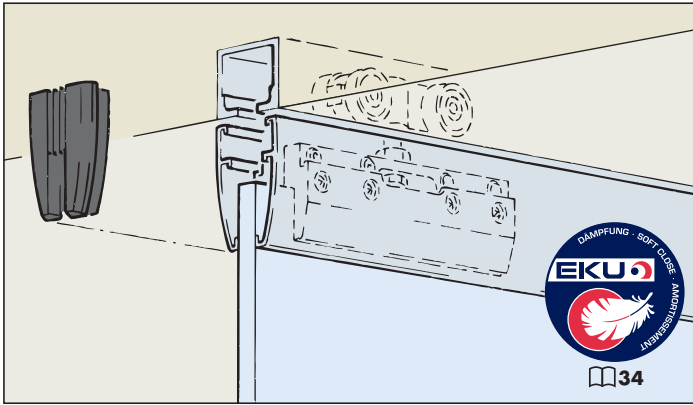

System: Standard-Laufschiene, deckenbündige Montage, für 1 Glastüre bis 100kg.

Design Alu-Blende zu Klemmschuh

System: Standard running track, installation flush with the ceiling, for 1 glass door up to 100kg.

Design Aluminium panel for clamping shoe

Système: Rail de roulement standard, montage affleurant avec le plafond, pour 1 porte en verre jusqu'à 100kg.

Design Cache en alu pour mâchoire de serrage

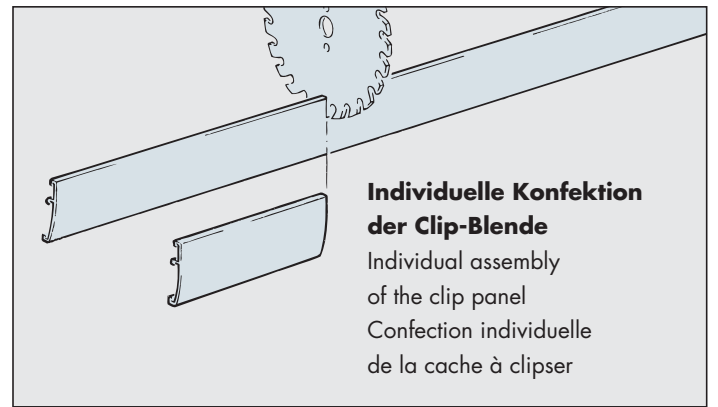
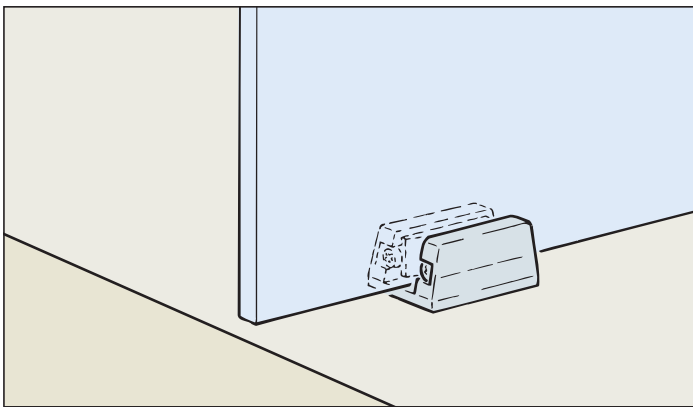

Individuelle Konfektion der Clip-Blende

Individual assembly of the clip panel

Confection individuelle de la cache à clipser

Einbaubeispiele ohne Glasbearbeitung

Mounting examples without machining of the glass / Exemples de montage sans usinage du verre

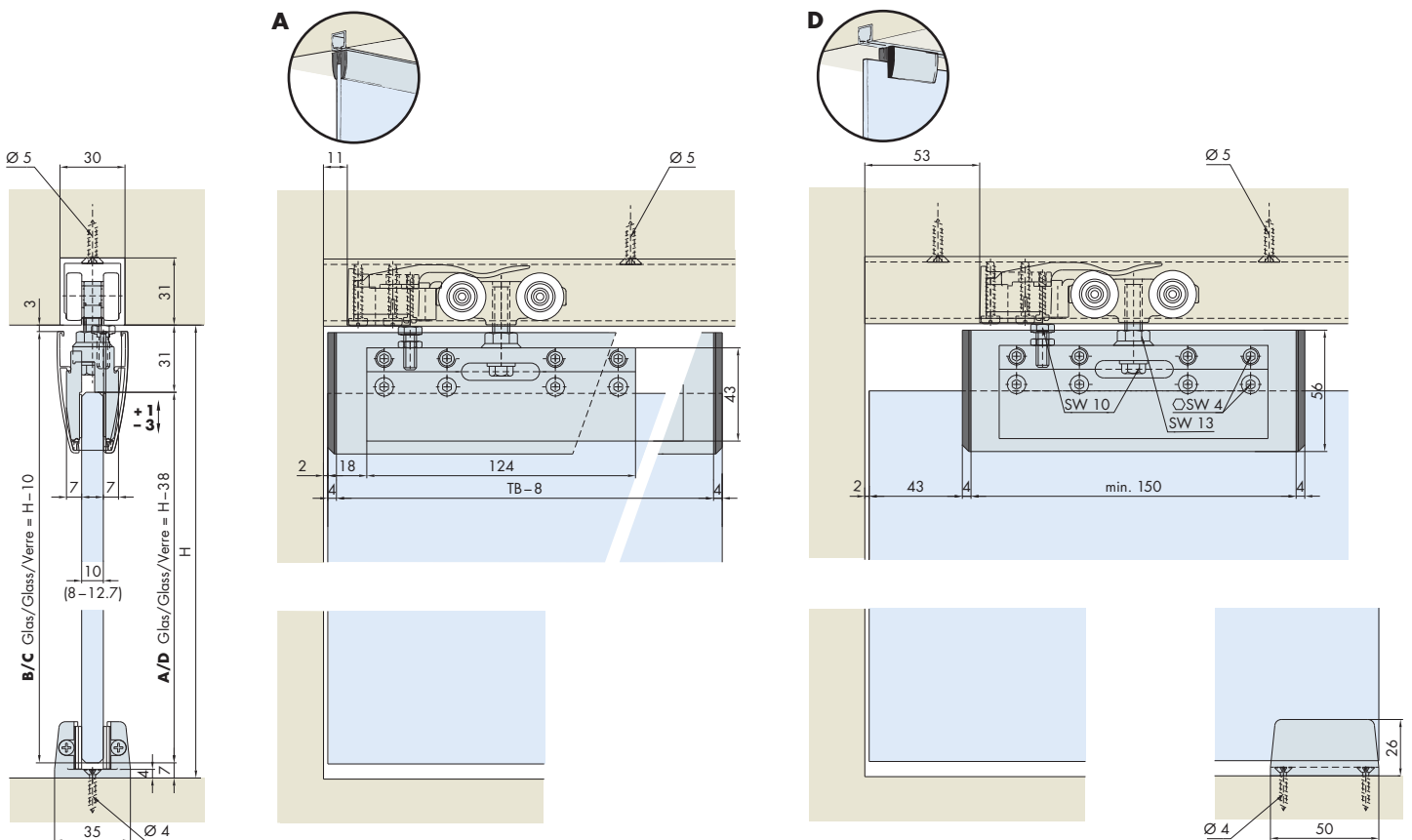





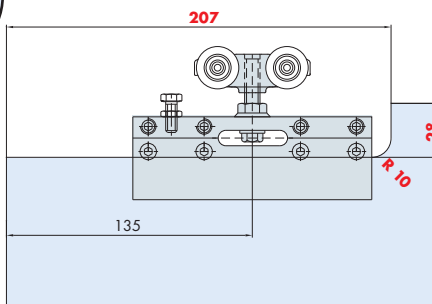
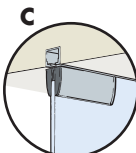
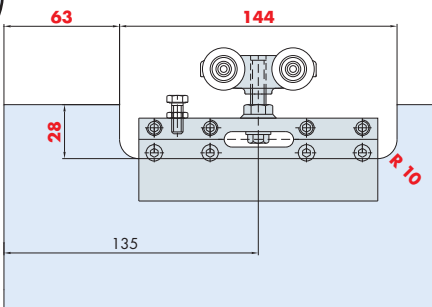
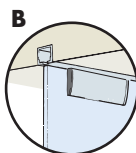
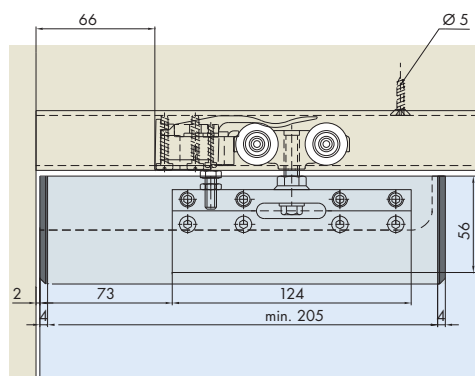
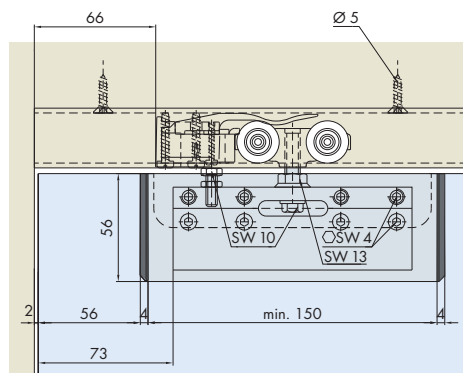

Einbaubeispiele mit Glasbearbeitung

Mounting examples with machining of the glass

Exemples de montage avec usinage du verre

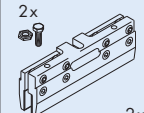
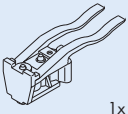

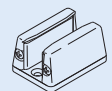
Garnituren / Sets / Garnitures

1 Türe Door Porte	No. 057.3074.071		
			2x
2x	2x	2x	2x
			1x
			1x



Türgewichte
Door weights
Poids de portes

39

Zubehör / Accessories / Accessoires

Laufschiene, Alu gelocht

Running track, aluminium pre-drilled
Rail de roulement, en alu perforé

Gr./Size	Art. No.
1700 mm	057.3016.170
2000 mm	057.3016.200
2500 mm	057.3016.250
6000 mm	057.3016.600

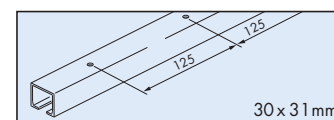

Laufschiene, Alu eloxiert, gelocht

Running track, aluminium anodized, pre-drilled
Rail de roulement, en alu anodisé, perforé

2000 mm	057.3016.201
2500 mm	057.3016.251
2500 mm	057.3016.256*
6000 mm	057.3016.601

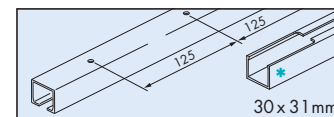

Clip-Blende zu Klemmschuh, Alu eloxiert

Clip panel for clamping shoe, aluminium anodized
Cache à clipser pour mâchoire de serrage, en alu anodisé

2500 mm	057.3039.250
6000 mm	057.3039.600

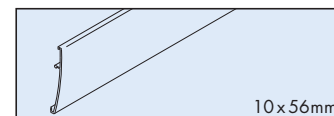

Endkappen-Set zu Blenden, Kunststoff anthrazit

End cap set for panels, plastic anthracite
Jeu d'embouts pour caches, plastique anthracite

2 x	057.3061.072
-----	--------------

A
B/C/D

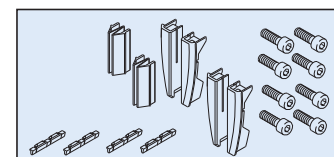

Türbearbeitung = rote Zahlen / Dimensions and drillings for door = red numbers / Traitement de portes = chiffres rouges

***Montageöffnung und Abdeckkappe / Assembly opening and cover cap / L'ouverture de montage et cache: □ 35**

Sonderzubehör / Special accessories / Accessoires spéciaux: □ 36

Technische Daten / Technical data / Caractéristiques techniques: □ 39

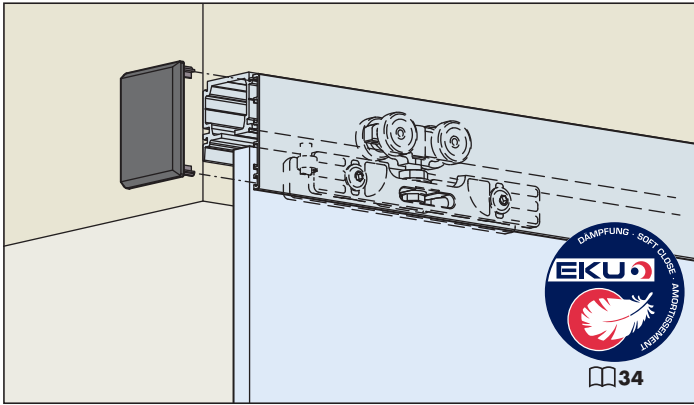

System: Combi-Laufschiene, Wand- oder Deckenmontage, Einbauhöhe 60mm, für 1 Glastüre bis 100 kg. Design Alu-Blenden zu Laufschiene

System: Combi running track, wall or ceiling mounting, installation height 60mm, for 1 glass door up to 100 kg. Design aluminium panels for running track

Système: Rail de roulement Combi, montage mural ou au plafond, hauteur d'installation 60mm, pour 1 porte en verre jusqu'à 100 kg. Design caches en alu pour rail de roulement

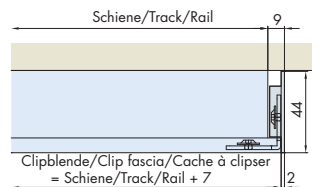
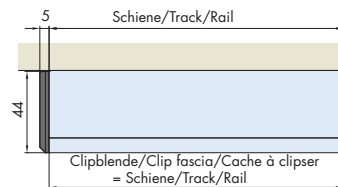
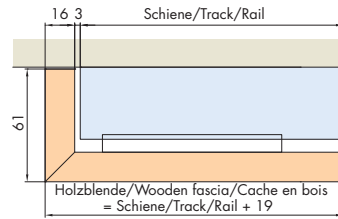
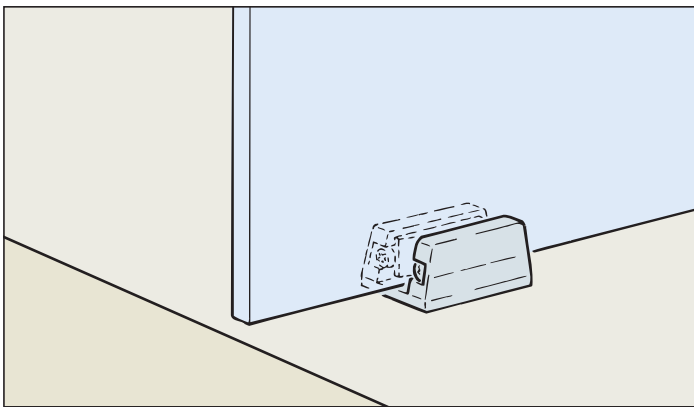

Einbaubeispiele / Mounting examples / Exemples de montage

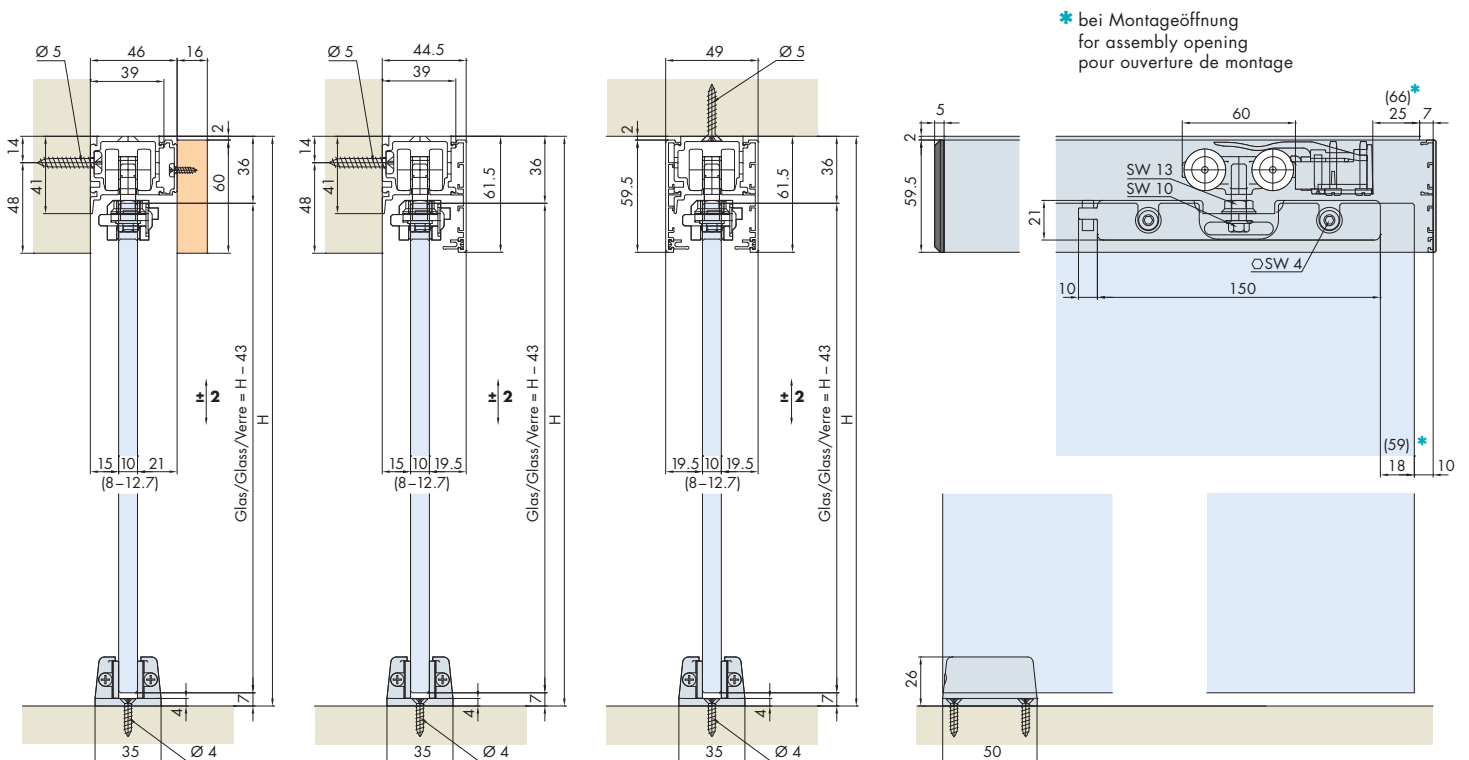

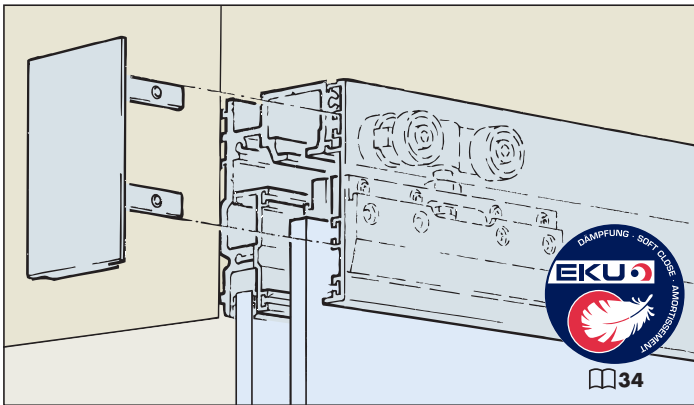

System: Laufschiene mit Festglashalterung, Wand- oder Deckenmontage für 1 Glastüre bis 100kg.

System: Top track with fixed glass support profile, wall- or ceiling mounted, for 1 glass door up to 100kg.

Système: Rail de roulement avec porte-verre fixe, montage mural ou au plafond, pour 1 porte en verre jusqu'à 100kg.

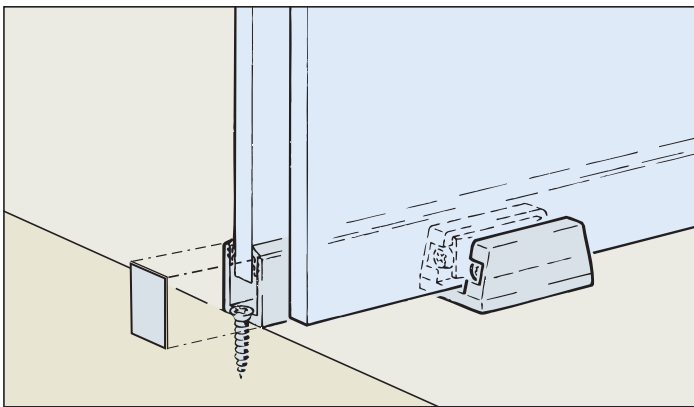

Einbaubeispiele / Mounting examples / Exemples de montage

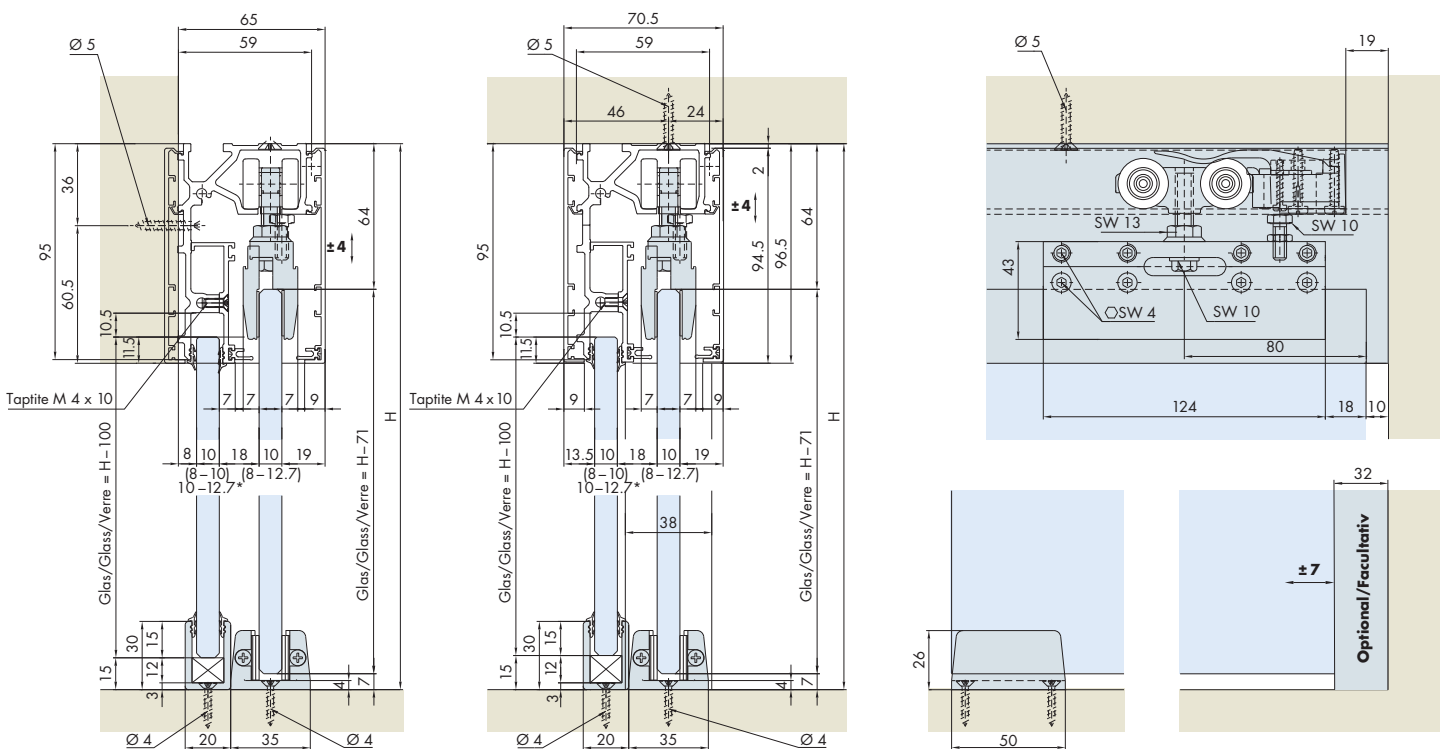

* 10–12.7 mm Glas, Nassversiegelung mit Silikon
 10–12.7 mm glass, wet caulking with silicone
 10–12.7 mm verre scellage au mouillé avec silicone
 Art. No. 098.0027.000 □ 36

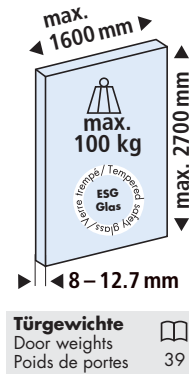
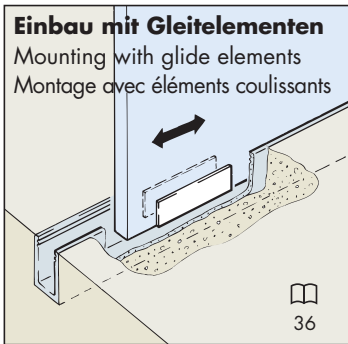

Garnituren / Sets / Garnitures

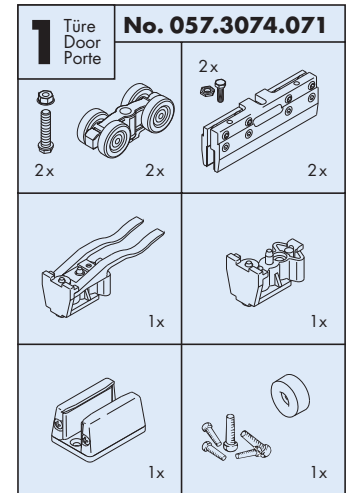

Zubehör / Accessories / Accessoires

Laufschiene Festglas, Alu gelocht

Running track fixed glass, aluminium pre-drilled
Rail de roulement vitre fixe, en alu perforé

Gr./Size	Art. No.
2500 mm	057.3053.250
3500 mm	057.3053.350
6000 mm	057.3053.600

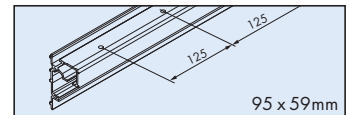

Festglashalteprofil, Alu eloxiert, gelocht

Fixed glass support profile, aluminium anodized, pre-drilled
Profil de retenue de porte-vitre fixe, en alu anodisé, perforé

2500 mm	057.3057.250
6000 mm	057.3057.600

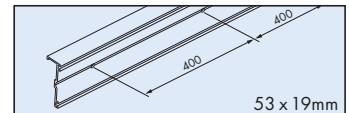

Befestigungs-Set zu 057.3056

Fixing set for 057.3056
Jeu de fixation pour 057.3056

057.3076.071

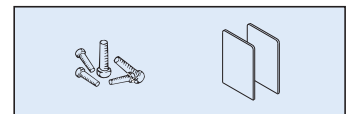

U-Führungsschiene, Alu eloxiert, gelocht

U-shaped guide track, aluminium anodized, pre-drilled
Rail de guidage U, en alu anodisé, perforé

2500 mm	057.3056.250
3500 mm	057.3056.350
6000 mm	057.3056.600

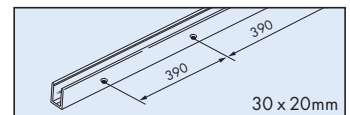

Clip-Blende zu Laufschiene, Alu eloxiert

Clip panel for running track, aluminium anodized
Cache à clipser pour rail de roulement, en alu anodisé

2500 mm	057.3050.250
3500 mm	057.3050.350
6000 mm	057.3050.600

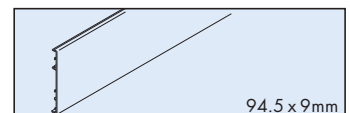

Blendenendstück-Set, Alu eloxiert, einseitig, Wandmontage

Panel end component set, aluminium anodized, one-sided, wall-mounting
Jeu d'extrémités de cache, en alu anodisé, un côté, montage mural

64.5 mm 057.3052.072

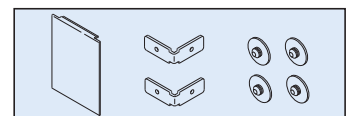

Blendenendstück-Set, Alu eloxiert, einseitig, Deckenmontage

Panel end component set, aluminium anodized, one-sided, ceiling-mounting
Jeu d'extrémités de cache, en alu anodisé, un côté, montage au plafond

70.5 mm 057.3052.073

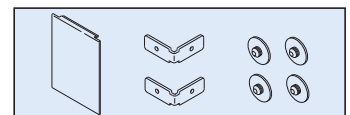

Dichtungsprofil, Kunststoff schwarz, in Rollen

Sealing profile, plastic black, in coils
Profil d'étanchéité, plastique noire, en rouleaux

20 m 057.3072.001

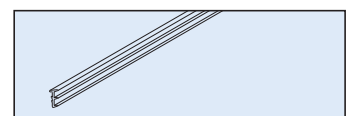

Sichtschutzdichtung, Kunststoff schwarz, in Rollen

Screening seal, plastic black, in coils
Joint pare-vue, plastique noir, en rouleaux

20 m 057.3078.002

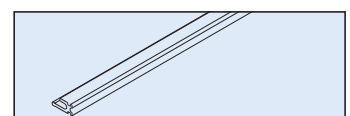

Optional: Wandausgleichsprofil, Alu eloxiert, mit Dichtung

Facultativ: Wall compensation profile, aluminium anodized, with sealing
Facultativ: Profil de compensation murale, en alu, anodisé, avec étanchéité

2500 mm	042.3064.071
3000 mm	042.3064.072

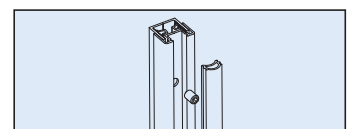

Sonderzubehör / Special accessories / Accessoires spéciaux: 36

Technische Daten / Technical data / Caractéristiques techniques: 39

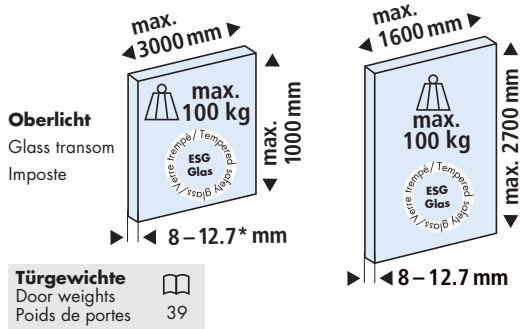

Wandbefestigung

Wall brackets
Fixation murale

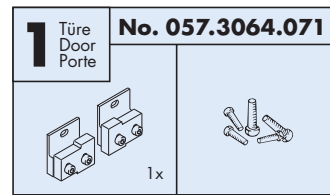

Garnituren / Sets / Garnitures

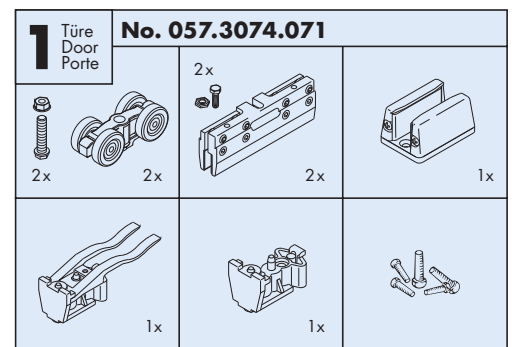

Zubehör / Accessories / Accessoires

Laufschiene Festglas, Alu gelocht

Running track fixed glass, aluminium pre-drilled
Rail de roulement en alu pour vitre fixe, perforé

Gr./Size

2500 mm 057.3053.250
3500 mm 057.3053.350
6000 mm 057.3053.600

Verstärkungsprofil, Alu eloxiert

Reinforcement profile, aluminium anodized
Profil de renforcement, en alu anodisé

2500 mm 057.3066.250
6000 mm 057.3066.600

Clipblende, Alu eloxiert, zu Laufschiene

Clip panel, aluminium anodized, for running track
Cache à clipser, en alu anodisé, pour rail de roulement

2500 mm 057.3050.250
3500 mm 057.3050.350
6000 mm 057.3050.600

Festglashalteprofil, Alu eloxiert, gelocht

Fixed glass support profile, aluminium anodized, pre-drilled
Profil de retenue en alu pour vitre fixe, anodisé, perforé

2500 mm 057.3057.250
6000 mm 057.3057.600

Glasfix-Winkelprofil, Alu eloxiert, zu Oberlicht seitlich, gelocht

Glassfix angled profile, aluminium anodized, for glass transom sideways, pre-drilled
Cornière de fixation latéral, en alu anodisé, perforé, pour l'imposte

2000 mm 057.3067.200
6000 mm 057.3067.600

Glasfix-Deckprofil, Alu eloxiert, zu Oberlicht seitlich

Glassfix cover profile, aluminium anodized, for glass transom sideways
Profil de recouvrement latéral, en alu anodisé, pour l'imposte

2000 mm 057.3068.200
6000 mm 057.3068.600

U-Führungsschiene, Alu eloxiert, gelocht

U-shaped guide track, aluminium anodized, pre-drilled
Rail de guidage U, en alu anodisé, perforé

2500 mm 057.3056.250
3500 mm 057.3056.350
6000 mm 057.3056.600

Befestigungs-Set zu 057.3056

Fixing set for 057.3056
Jeu de fixation pour 057.3056

057.3076.071

Dichtungsprofil, Kunststoff schwarz, in Rollen

Sealing profile, plastic black, in coils
Profil d'étanchéité, plastique noir, en rouleaux

20 m 057.3072.001

Sichtschutzdichtung, Kunststoff schwarz, in Rollen

Screening seal, plastic black, in coils
Joint pare-vue, plastique noir, en rouleaux

20 m 057.3078.002

Optional: Wandausgleichsprofil, Alu eloxiert, mit Dichtung

Facultativ: Wall compensation profile, aluminium anodized, with sealing
Facultativ: Profil de compensation murale, en alu, anodisé, avec étanchéité

2500 mm 042.3064.071
3000 mm 042.3064.072

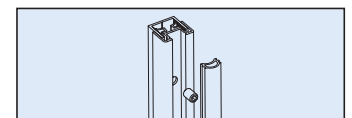
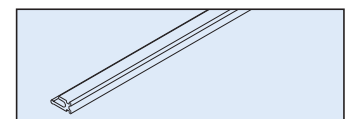
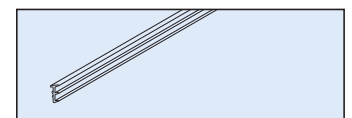
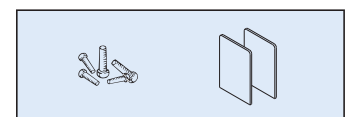
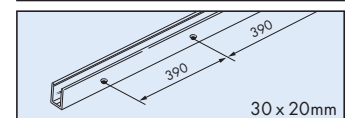
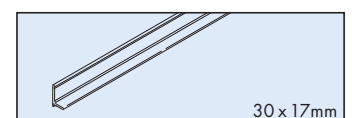
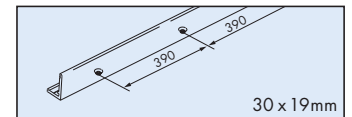
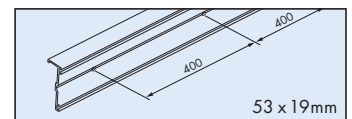
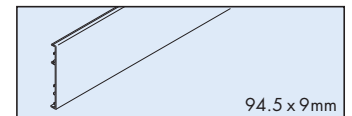
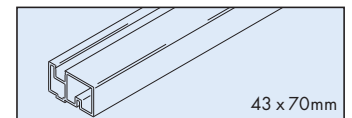
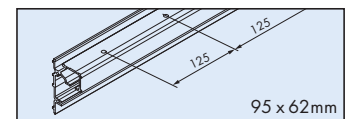

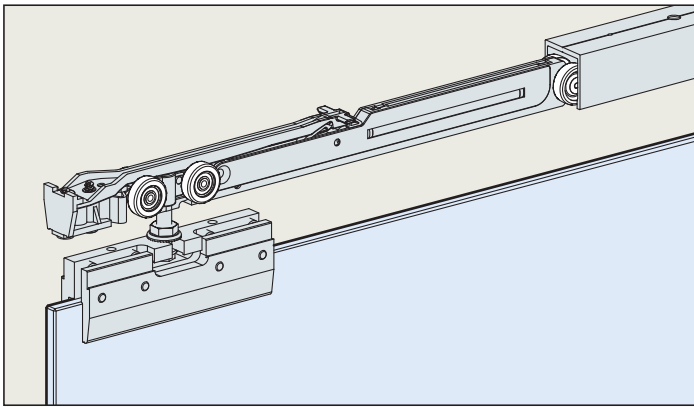

System: Einzugsdämpfung, bis zu 60 oder 100kg, für leisen und sanften Schiebekomfort, bei obenlaufenden Glstüren für EKU-PORTA 100 Glas Systeme.
Design: Einzugsdämpfung in Laufschiene integriert.

System: Soft and self closing system, up to 60 or 100kg, for quiet and gentle sliding comfort with top-running glass doors for EKU-PORTA 100 Glass systems.
 Design: Soft and self closing system integrated in the running track.

Système: Amortissement pour retour automatique par traction jusqu'à 60 ou 100kg, pour un confort de coulissement doux et silencieux, pour portes en verre à roulement en haut pour systèmes EKU-PORTA 100 Verre.

Design: Amortissement pour retour automatique par traction intégré au rail de roulement.

Einbaubeispiele / Mounting examples / Exemples de montage

Laufschiene mit Montageöffnung und Abdeckkappe / Running track with assembly opening and cover cap / Rail de roulement avec ouverture de montage et cache

Laufschiene, deckenbündige Montage mit Montageöffnung und Abdeckkappe – erlaubt nachträgliche Montage der Einzugsdämpfung durch Montageöffnung.
 Running track, for installing flush with ceiling, assembly opening and cover cap – allows the soft and self closing system to be retrofitted through the assembly opening.
 Rail de roulement, montage affleurant avec le plafond, ouverture de montage et cache – permet un montage ultérieur de l'amortissement pour retour automatique par traction.

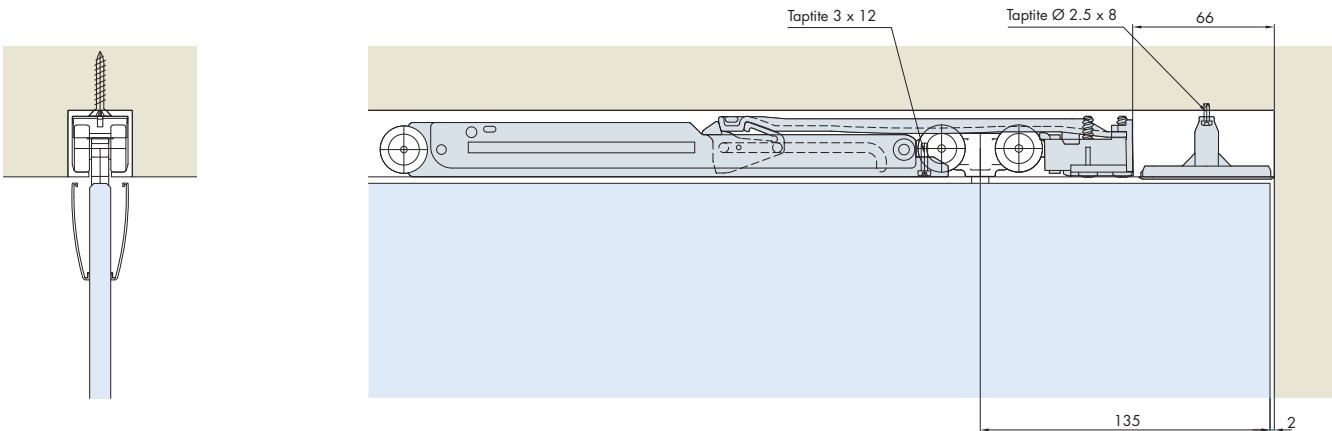

Laufschiene ohne Montageöffnung und Abdeckkappe / Running track without assembly opening and cover cap / Rail de roulement sans ouverture de montage et cache

Laufschiene, Wandmontage ohne Montageöffnung – Montage der Einzugsdämpfung sollte seitlich erfolgen.
 Running track, for wall mounting without assembly opening – soft and self closing system should be installed at the side.
 Rail de roulement, montage mural sans ouverture de montage – le montage de l'amortissement pour retour automatique par traction doit s'effectuer sur le côté.

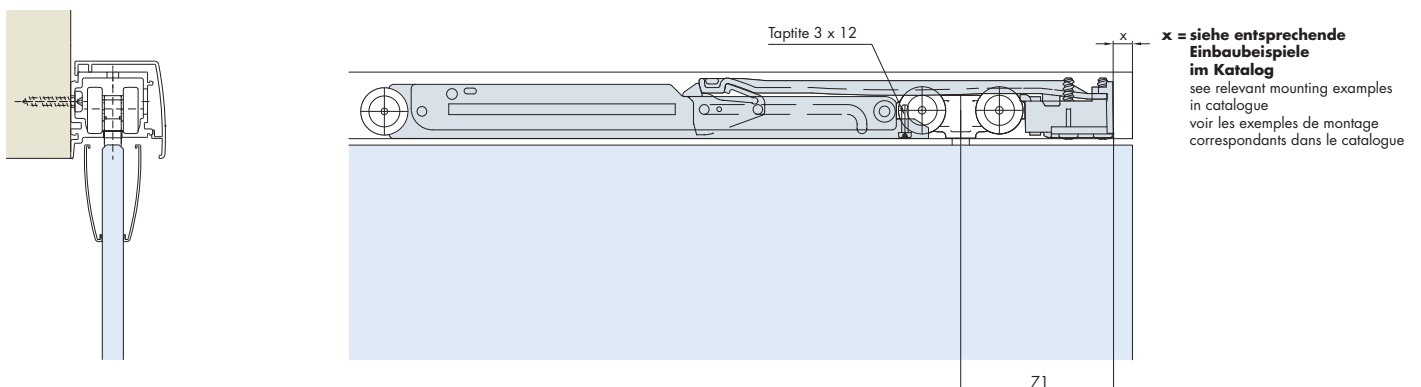

Montageöffnung / Assembly opening / Apertura di montaggio

Die Montageöffnung stellt sicher, dass die Lauftechnik und Einzugsdämpfung nachträglich eingebaut werden können, ohne dass die Laufschiene demontiert werden muss. Die Schiebetüre ist schnell montiert oder demontiert. Zudem erleichtert die Montageöffnung die Reinigung der Laufschiene, für einen ruhigen Lauf der Rollen. Für folgende Einbausituationen wird eine Montageöffnung empfohlen:

- bei deckenbündigem Einbau der Laufschiene
- wenn seitlicher Zugang für das Einfahren der Einzugsdämpfung nicht gewährleistet ist (min. 62mm)

The assembly opening ensures that the running system and the soft and self closing system can be retrofitted without the running track having to be removed. The sliding door can be installed or removed quickly. Moreover, the assembly opening makes it easier to clean the running track for smooth running of the rollers.

The assembly opening is recommended for the following installation situations:

- with running track installed flush with the ceiling
- if side access for retracting the soft and self closing system is not available (min. 62mm)

L'ouverture de montage garantit la possibilité d'un montage ultérieur de la technique de roulement et de l'amortissement pour retour automatique par traction sans qu'il soit nécessaire de démonter le rail de roulement. La porte coulissante peut ainsi être rapidement montée et démontée. Par ailleurs, l'ouverture de montage facilite le nettoyage du rail de roulement pour une course silencieuse des galets.

L'ouverture de montage est recommandée pour les situations de montage suivantes:

- montage du rail de roulement affleurant au plafond
- lorsqu'un accès latéral pour la mise en place de l'amortissement pour retour automatique par traction n'est pas assuré (min. 62 mm)

Garnituren / Sets / Garnitures

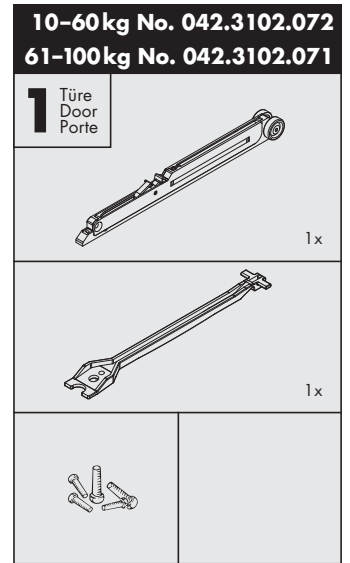
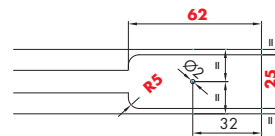
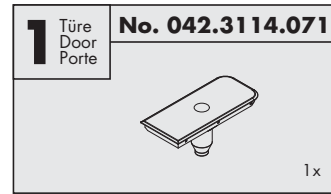

Dämpfen in Schliessrichtung Soft closing function in closing direction Amortissement dans le sens de fermeture ➔	▲ 10-60kg 042.3102.072 ▲ 61-100kg 042.3102.071	1 x bestellen Order 1 x Commander 1 x
Dämpfen in Schliess- und Öffnungsrichtung Soft closing function in opening and closing direction Amortissement dans le sens de fermeture et d'ouverture ↔	▲ 10-60kg 042.3102.072 ▲ 61-100kg 042.3102.071	2 x bestellen Order 2 x Commander 2 x

Zubehör / Accessories / Accessoires

Fräslöhre für Montageöffnung (nicht geeignet bei EKU-PORTA 100 GF/GFO) 042.3118.071

Routing jig for assembly opening (unsuitable for EKU-PORTA 100 GF/GFO)

Gabarit de fraisage pour ouverture de montage (ne convient pas pour EKU-PORTA 100 GF/GFO)

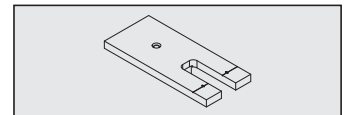

Nutfräser HM (Hartmetall)

Groove cutter HM (hard metal)

Fraise à rainurer HM (métal dur)

600.0000.309

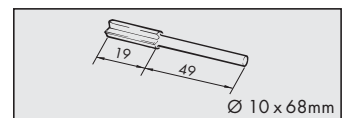

Dämpfen in Schliessrichtung / Soft closing in closing direction / Amortissement dans le sens de fermeture

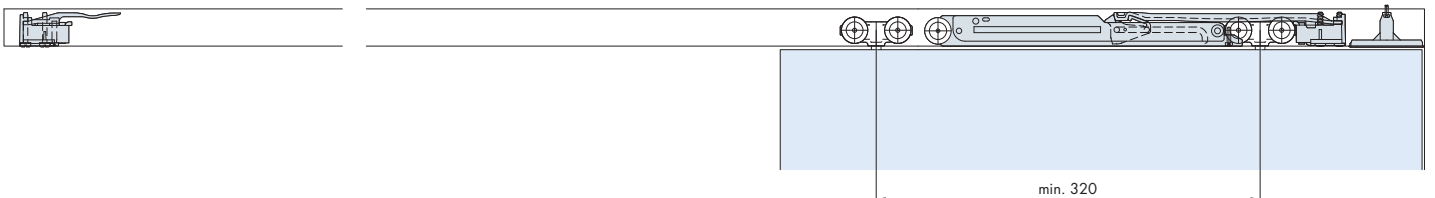

Dämpfen in Schliess- und Öffnungsrichtung / Soft closing in closing and opening direction / Amortissement dans le sens de fermeture et d'ouverture

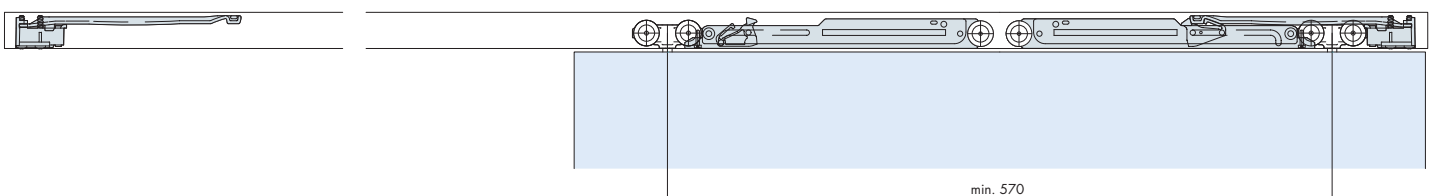

Zubehör / Accessories / Accessoires	Gr./Size	Art. No.	
Glaskantenschutzprofil, Kunststoff glasklar Protective transparent edge trims, plastic transparent Profils protecteurs de chant de verre, plastique transparent	10mm/3000mm 12mm/3000mm 12.7mm/3000mm	751.0001.300 751.0002.300 751.0003.300	
Doppelseitiges Klebeband zu Glaskantenschutzprofil, in Rollen Double-sided adhesive tape for protective edge trims, in coils Ruban adhésif double face pour profil protecteur de chant de verre	50 m	751.0004.000	
Glaskantenschutzprofil, Kunststoff schwarz, selbstklebend, in Rollen Protectiv edge trims, plastic black, self-adhesive, in coils Profils protecteurs de chant de verre, plastique noir, autocollants, en rouleaux	10 m	057.3080.002	
Selbstklebende Gleitelemente, für 8 mm Glas im Set Self-adhesive sliders, for 8 mm glass in a set Jeu d'éléments à coulisse autocollants, pour verre 8 mm	 6x	751.0005.000	
Selbstklebende Gleitelemente, für 10 mm Glas im Set Self-adhesive sliders, for 10 mm glass in a set Jeu d'éléments à coulisse autocollants, pour verre 10 mm	 6x	751.0006.000	
Klebstoff Ceresit Silikon, 310 ml Glue Ceresit silicone, 310 ml Colle Ceresit silicone, 310 ml		098.0027.000	
Frässhablone, für EKU-PORTA 100 GW, GWF (Synchro) Milling jig, for EKU-PORTA 100 GW, GWF (Synchro) Gabarit de fraisage, pour EKU-PORTA 100 GW, GWF (Synchro)		057.3094.001	
Nutfräser HM (Hartmetall) Groove cutter HM (hard metal) Fraise à rainurer HM (métal dur)		600.0000.309	
Einwegabdeckung, Kunststoff, für EKU-PORTA 100 GW/GWF Disposable cover, plastic, for EKU-PORTA 100 GW/GWF Recouvrement des rails à usage unique, plastique, pour EKU-PORTA 100 GW/GWF	2000 mm	057.3089.001	
Einwegabdeckung, Kunststoff, für EKU-PORTA 100 Disposable cover, plastic, for EKU-PORTA 100 Recouvrement des rails à usage unique, plastique, pour EKU-PORTA 100	2000 mm	057.3098.001	
Schienenreiniger, Kunststoff Track cleaner, plastic Nettoyant pour rails, plastique		057.3099.071	
Bodenführung spielfrei einstellbar, Wandmontage, für EKU-PORTA 100 Bottom guide adjustable playfree, wall mounting, for EKU-PORTA 100 Guidage au sol réglable sans jeu, montage mural, pour EKU-PORTA 100		057.3015.175	
Clip-Teil für Holzblende, Alu, gelocht (alle 500 mm) Clip component for wooden panel, aluminium pre-drilled (every 500 mm) Clip en alu pour cache en bois, en alu perforé (tous les 500 mm)		057.3117.001	

Zubehör / Accessories / Accessoires
EKU-PORTA 100, mit Kugellager

EKU-PORTA 100, with ball bearings

EKU-PORTA 100, avec roulement à billes

Gr./Size

Art. No.

057.3114.071

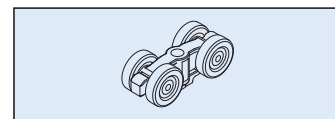
Klemmschuh Alu für Glasstärke 8–12.7 mm

Clamping shoe aluminium to suit glass thickness 8–12.7 mm

Mâchoire de serrage alu pour vitre de 8 à 12.7 mm d'épaisseur

057.3032.071

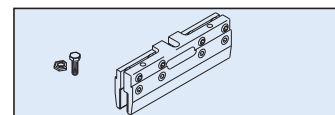
**G/GF/GFO
GU/GM**

Tragschraube M8 x 32, Stahl verzinkt

Suspension bolt M8 x 32, zinc-plated steel

Vis porteuse M8 x 32, en acier zingué

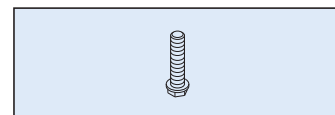
057.0123.104

Mutter M8, Stahl verzinkt

Nut M8, zinc-plated steel

Ecrou M8, en acier zingué

768.9005.101

Klemmschuh Alu für Glasstärke 8–12.7 mm

Clamping shoe aluminium to suit glass thickness 8–12.7 mm

Mâchoire de serrage alu pour vitre de 8 à 12.7 mm d'épaisseur

057.3087.071

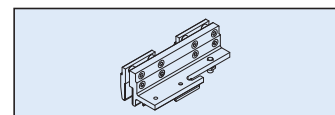
GW/GWF

Tragschraube M8 x 25, Stahl schwarz

Suspension bolt M8 x 25, steel black

Vis porteuse M8 x 25, en acier noir

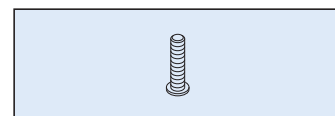
600.0000.473

Stopper mit einstellbarer Arretierkraft, Kunststoff grau

Stopper with adjustable retention spring, plastic grey

Butée avec force réglable, plastique gris

057.3073.072

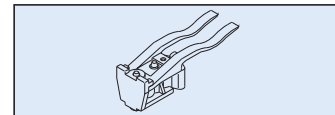
Stopper ohne Rückhaltefeder, Kunststoff grau

Stopper without retention spring, plastic grey

Butée sans ressort de blocage, plastique gris

057.3073.071

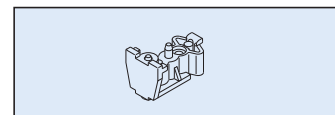
Bodenführung spielfrei einstellbar, matt verchromt

Bottom guide adjustable playfree, chrome plated matt

Guidage au sol réglable sans jeu, chromé mat

057.3030.071

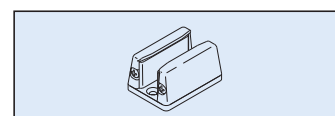
**G/GF/GFO
GU/GM**

Bodenführung spielfrei einstellbar, matt verchromt

Bottom guide adjustable playfree, chrome plated matt

Guidage au sol réglable sans jeu, chromé mat

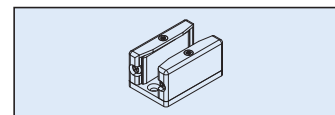
057.3082.071

GW/GWF

Blendenclip, Kunststoff grau, alle 200 mm

Clip for panel, plastic grey, every 200 mm

Clip pour cache, plastique gris, tous les 200 mm

12 x

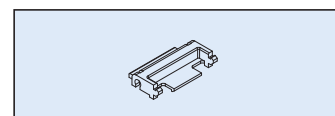
057.3086.051

GW/GWF

Wandpuffer, Gummi schwarz

Wall buffer, black rubber

Butoir mural, caoutchouc noir

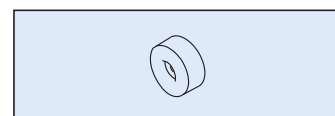
024.0002.046

Bodenstopper, matt verchromt

Bottom door stopper, chrome plated matt

Butée au sol, chromé mat

751.0018.000

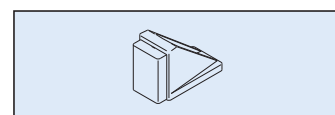

Floatglas	ESG	VSG aus Floatglas	VSG aus ESG	VSG aus TVG
Float glass	Tempered safety glass	Laminated glass made from float glass	Laminated glass made from tempered safety glass	Laminated glass made from heat-strengthened glass
Floatglas (vitre)	ESG	VSG issu de Floatglas	VSG issu de ESG	VSG issu de TVG

MÖBEL/FURNITURE/MEUBLES					
EKU-CLIPO GR, GPK, GPPK, G	[o]	●			
EKU-CLIPO GS, GK		●	[o]		
EKU-COMBINO GR	[o]	●			
EKU-CREATION GAK		●	[o]	■	■
EKU-FRONTAL GR	[o]	●			■
EKU-FRONTAL GK		●		■	■
EKU-REGAL A GR	[o]	●			
EKU-REGAL B SP, HG, GK		●	[o]	■	■
EKU-REGAL C GR, GPPK	[o]	●			

BAU/BUILDING/BÂTIMENT					
EKU-DIVIDO 80/100 GR, GRM, Synchro		●	[o]	[o]	[o]
EKU-PORTA 40 GE		●	[o]	■	■
EKU-PORTA 100 G, GU, GM, GF, GFO		●	[o]	■	■
EKU-PORTA 100 GW, GWF, GMD		●		■	■
EKU-BANIO 40 GF, GFE		●		■	●

- **Empfehlung EKU/Recommended by EKU/Recommandation par EKU**

[o] **Mit Einschränkungen (Floatglas bezüglich Bruchsicherheit/VSG aus Floatglas bezüglich Optik der Glaskanten)**
 With restrictions (float glass due to breaking resistance/laminated glass made from float glass due to appearance of glass edges)
 Avec restrictions (Floatglas en raison de la résistance à la rupture/VSG issu de Floatglas en raison de l'aspect des arêtes de verre)

- **Anwendung aus optischen Gründen nicht zu empfehlen, da produktionstechnisch ein Versatz von bis zu 4 mm möglich ist.**
 Application not recommended for aesthetic reasons, since misalignment of up to 4 mm may occur due to technical reasons during production.
 Utilisation non recommandée pour des raisons d'optique car, pour des impératifs techniques, un décalage jusqu'à 4 mm est possible.

Float

Floatglas ist das konventionelle Bauglas, welches im sogenannten Floatprozess (schwimmend auf Zinn) hergestellt wird.

Float glass is conventional structural glass that is manufactured using the so-called float process (floating on a bath of molten tin).

Floatglas (vitre) est un verre de construction conventionnel, obtenu par coulée continue et flottage sur un bain d'étain.

ESG

Das **Einscheiben-Sicherheitsglas** ist ein vorgespanntes Glas. Die Herstellung erfolgt durch eine spezielle Wärmebehandlung. Beim Scheibenbruch zerfällt das ESG in ein engmaschiges Netz aus unscharfen Glaskrümeln. Einscheiben-Sicherheits-Glas weist eine hohe Elastizität, Biegebruchfestigkeit, Schlagfestigkeit und Temperaturwechselbeständigkeit auf.

Tempered safety glass is strengthened glass. It is manufactured using special heat treatment. When the glass breaks, tempered safety glass shatters into small blunt-edged fragments. Tempered safety glass has extremely good resilience to breakage, bending resistance, impact resistance and thermal shock resistance.

ESG est un verre de sécurité trempé (précontraint). Sa fabrication intervient sous traitement thermique spécial. Lorsqu'il se brise, il se transforme en un filet à fin maillage de grains de verre non-coupant. Le verre de sécurité trempé fait preuve d'une grande élasticité et d'une grande résistance à la flexion, aux chocs et aux variations de température.

VSG

Beim **Verbund-Sicherheitsglas** werden zwei oder mehrere übereinanderliegende Glasscheiben durch eine oder mehrere hochelastische Folien (0.38–max. 0.76 mm) aus Polyvinylbutyral (PVB) fest miteinander verbunden. Beim Bruch einer VSG-Scheibe bleiben die Bruchstücke an der Folie haften.

Laminated glass is produced by bonding two or more of glass together by means of one or more extremely flexible polyvinyl butyral (PVB) interlayers (0.38–max. 0.76 mm). When laminated glass breaks, the fragments adhere to the interlayer.

VSG le verre de sécurité feuilleté est un verre composé de deux ou plusieurs vitres, fermement assemblées par un ou plusieurs films (0.38–max. 0.76 mm) en PVB (polyvinylbutyral) à élasticité élevée. Lorsque le verre se brise, les morceaux adhèrent au(x) film(s) intercalaire(s).

TVG

Teilvorgespanntes Glas ist ein thermisch behandeltes Floatglas. TVG weist ein ähnliches Bruchbild auf wie thermisch unbehandeltes Glas. Trotzdem hat TVG eine höhere Widerstandsfähigkeit gegenüber Druck und Stoss als unbehandeltes Glas.

Heat-strengthened glass is thermally treated float glass and has a breakage pattern similar to glass that has not been thermally treated. It is more resistant to stress and impact than untreated glass.

TVG est un verre Floatglas durci thermiquement induisant une contrainte superficielle. Son comportement lorsqu'il se brise est sensiblement identique à celui d'un verre non traité thermiquement. Cependant le verre durci présente une capacité de résistance supérieure à la pression et aux chocs par rapport au verre non traité.

TÜRGEWICHTE

Door weights | Poids de vantaux



		Türgewichte Glas Panel weights glass Poids de portes verre						Türgewichte Glas Panel weights glass Poids de portes verre	
D	mm	6	8	10	12.7	D	mm	10	12.7
B	x					B	x		
700	x	22.1	29.4	36.7	46.7	700	x	42.0	53.4
750	x	23.6	31.5	39.3	50.0	750	x	45.0	57.2
800	x	25.2	33.6	42.0	53.4	800	x	48.0	61.0
850	x	26.8	35.7	44.6	56.7	850	x	51.0	64.8
900	x	28.4	37.8	47.2	60.1	900	x	54.0	68.6
950	x	30.0	39.9	49.8	63.4	950	x	57.0	72.5
1000	x	31.5	42.0	52.5	66.7	1000	x	60.0	76.3
1100	x	---	46.2	57.7	73.4	1100	x	66.0	83.9
1200	x	---	50.4	63.0	80.1	1200	x	72.0	91.5
1300	x	---	54.6	68.2	86.8	1300	x	78.0	99.2
1400	x	---	58.8	73.5	93.4	1400	x	84.0	---
1500	x	---	63.0	78.7	---	1500	x	90.0	---
1600	x	---	67.2	84.0	---	1600	x	96.0	---
						1000	x	67.5	85.9
						1200	x	81.0	---
						1300	x	87.8	---
						1400	x	94.5	---
	kg/m ²	15.0	20.0	25.0	31.8		kg/m ²	25.0	31.8

Angaben ohne Gewähr

Details without responsibility for correctness

Données sans engagement de notre part

TECHNISCHE DATEN

Technical data | Caractéristiques techniques

• EKU-Produkte sind nach DIN-EN 1527, inklusive Herausfalltest DIN-EN 15706, getestet.

EKU products have been tested in accordance with DIN-EN 1527, incl. fall-out test in accordance with DIN-EN 15706.

Les produits EKU sont testés conformément à la DIN-EN 1527, y compris le test de chute selon DIN-EN 15706.

• Max. Türgegewichte und Türmasse siehe jeweilige Katalogseiten.

Das max. Türgegewicht darf nicht überschritten werden!

Max. door weights and door dimensions see respective catalogue pages.

The maximum door weight may not be exceeded!

Max. poids et dimensions de vantaux voir pages correspondantes du catalogue.

Le poids de porte maximal ne doit pas être dépassé!

• Die Produkte sind nicht für Aussenanwendungen geeignet.

The products are inapplicable for outdoor applications / use.

Les produits sont inappropriés pour des applications extérieures / l'usage extérieur

• Längenmasse der Profile aus dem EKU-Sortiment unterliegen der DIN ISO 2768-1 c (+/- 4 mm)

The length dimensions of the profiles from the EKU range are subject to DIN ISO 2768-1 c (+/- 4 mm)

Les longueurs des profilés de la gamme EKU sont conformes aux exigences de la norme DIN ISO 2768-1 c (+/- 4 mm)

• Technische Änderungen vorbehalten.

Subject to technical modifications.

Sous réserve de modifications techniques.





07 2016

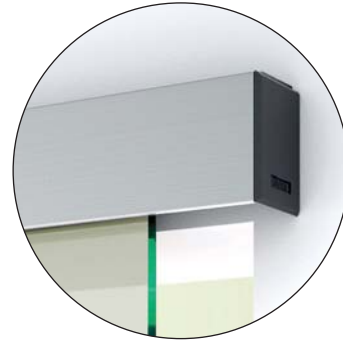

Vertrieb über den Fachhandel
Available through specialised distributors
Distribution par le commerce spécialisé

**Per Mausclick zur
intelligenten Schiebe-Lösung:**

With a click of the mouse
you arrive at the intelligent
sliding solution:

Un clic de souris et vous
arrivez à la solution intelligente
pour portes coulissantes:

www.eku.ch



EKU AG, Schiebelösungen, Wilerstrasse 90, 8370 Sirnach, Switzerland, Tel.+41 (0)71 96 96 100
Fax +41 (0)71 96 96 110, office@eku.ch, Certified ISO 9001 – Member of the HAWA Group