



**NEXIS**



**G\* GRASS<sup>®</sup>**

## **NEXIS HINGE SYSTEMS**

Our versatile hinge systems offer added value through a number of design solutions, proven technology, functionality and operating comfort.





Efficient and reliable. The versatile Nexis hinge system offers snap-on installation technology for a variety of cabinetry applications with a Soft-close or Self-close closing action.

**Reliable Snap-on hinges with opening angles from 95° to 170° for long-lasting everyday service**

The Nexis hinge series offers a wide variety of hinges for standard door applications, specialty door applications, and frame and frameless applications. Opening angle ranging from 95° to 170°, Nexis is offered in a screw-on and dowelled version in a 42mm, 45mm, 48mm boring pattern and the Nexis Impresso, tool-free installation, is offered in a 42/45mm and 45/48mm boring pattern.

Nexis Snap-on hinges attach to Nexis base plates with an audible click. Installation is user-friendly and reliable. Just pressing down the hinge with a finger is enough to attach it to the base plate. The hinge can be detached from the Snap-on base plate by simply releasing it with the lever at the front of the hinge arm.



## NEXIS HINGE SYSTEM

Snap-on technology:  
Quick mounting, efficient, secure.



**Nexis Impresso**  
**Quick, simple and reliable**  
**hardware without tools.**

The Nexis Impresso hinge series is designed to assemble quickly and easily without tools. This is especially useful in cabinetry that is flat-packed and shipped unassembled with pre-drilled doors.

The Nexis Impresso hinge can be installed quickly and accurately on site. Simply insert the Nexis Impresso hinge into the bored door and close the hinge flap to engage. The hinge sits firmly and securely in the door and does not allow for twisting due to a 3 point connection of the hinge cup to the door.

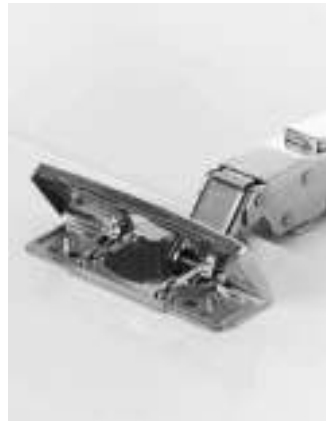

The Nexis Impresso is perfect for door material such as particle board, solid wood, and MDF board.

**Hinge cup with 'combination'**  
**drilling pattern.**

All Impresso hinges are offered in a combination drilling pattern. Available combinations include a 42mm/45mm pattern and a 45mm/48mm pattern. Any Nexis Impresso hinge cup is suitable for at least two drilling patterns and covers all boring patterns offered in today's market.

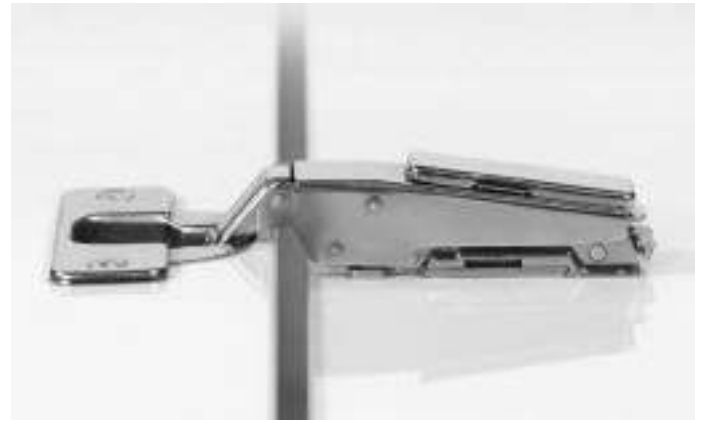

**Nexis - Proven technology**  
**makes Nexis the classic choice**  
**among hinge systems.**

The Nexis hinges series offers added value through a number of design solutions that will meet any application requirements whether it be frame or frameless. Choose from hinge opening angles ranging from 95° to 170° and from hinges designed for special applications such as negative angle and pie cut corner applications.

The Nexis series is available in a screw-on or dowelled version and is offered in a 42mm, 45mm, and 48mm boring pattern. The Nexis base plates offer cam adjustment,

3 point fixing, screw-on or Euro screw versions for frame and frameless cabinetry. The plates mount easily in a user friendly snap-on method. Just one push connects the hinge to the plate.

**Add a touch of innovation**  
**with the unique Soft-close®**  
**controlled closing device to bring**  
**a calming quiet to closing doors.**

During the closing action, the Soft-close creates a cushion that controls and slows the door to a gentle stop. The Soft-close device attaches easily without tools for a simple installation.

# Nexis

## Table of Content











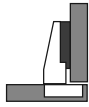
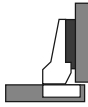
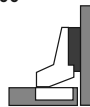

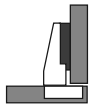
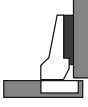

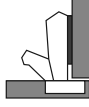
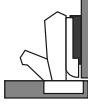

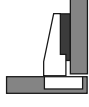
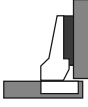
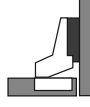

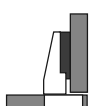
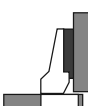



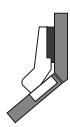

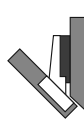

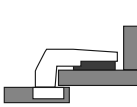
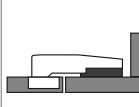

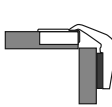

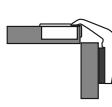



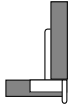
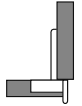
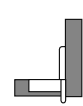

Opening Angle		Description	Full Overlay	Half Overlay	Inset	Page
		<b>Features &amp; Benefits</b>				6
		<b>Technical Information</b>				8
110°		<b>Nexis 110</b> <ul style="list-style-type: none"> <li>For standard doors</li> <li>Soft-close compatible</li> </ul>			<b>100°</b> 	14
125°		<b>Nexis 125</b> <ul style="list-style-type: none"> <li>For standard doors</li> <li>Soft-close compatible</li> </ul>				16
170°		<b>Nexis 170</b> <ul style="list-style-type: none"> <li>Wide-angle hinge with Zero protrusion</li> <li>Soft-close compatible</li> </ul>				18
95°		<b>Nexis 95</b> <ul style="list-style-type: none"> <li>Designed for profile doors or thicker doors</li> <li>Soft-close compatible</li> </ul>				20
95°		<b>Nexis 95/40</b> <ul style="list-style-type: none"> <li>Designed for profile doors</li> <li>For thick doors up to 35mm thickness</li> <li>Excellent load-bearing capacity</li> <li>40mm cup drilling diameter</li> </ul>				22
95°		<b>Nexis 95/+45°</b> <ul style="list-style-type: none"> <li>For +45° angle corner cabinet</li> <li>Soft-close compatible</li> </ul>		<b>Corner Angle</b> 		24
125°		<b>Nexis 125/-45°</b> <ul style="list-style-type: none"> <li>For negative 45° angle corner cabinet</li> </ul>				26
95°		<b>Nexis 95/90</b> <ul style="list-style-type: none"> <li>For blind corner application</li> <li>Soft-close compatible</li> </ul>				28
110°		<b>Nexis PCC</b> <ul style="list-style-type: none"> <li>For Pie-cut corner application</li> <li>For door thicknesses 16 to 22mm</li> </ul>				30
110°		<b>Nexis 21 PCC</b> <ul style="list-style-type: none"> <li>For pie-cut corner application</li> <li>For door thicknesses 14 to 24mm</li> </ul>				32

Table of Content

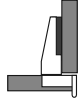
Opening Angle		Description	Full Overlay	Half Overlay	Inset	Page
95°		<b>Nexis 17 GL</b> <ul style="list-style-type: none"> <li>For glass door application</li> <li>For glass thicknesses 4 to 6mm</li> <li>26mm cup drilling diameter</li> </ul>				34
		<b>Nexis base plates</b> <ul style="list-style-type: none"> <li>For Nexis Impresso and Nexis hinges</li> </ul>				36
		<b>Soft-close for Nexis Impresso and Nexis UniSoft</b>				40 44
		<b>Tipmatic Plus</b> <b>Tipmatic</b>				45
<b>Institutional Hinges</b>						50
		<b>Institutional hinge</b> <ul style="list-style-type: none"> <li>For side panel thicknesses of 19mm (3/4")</li> <li>Opening angles from 270° - 180°</li> </ul>				52
270°		<b>Nexis Slide-on 73 Institutional hinge</b> <ul style="list-style-type: none"> <li>For door thicknesses 15 to 21mm</li> <li>With wide-angle opening</li> </ul>				54
<b>Specialty Hinge Items</b>						56
90°		<b>Tri-view-mirror hinge</b> <ul style="list-style-type: none"> <li>For medicine cabinets</li> </ul>				57
		<b>975 VZ PCC</b> <ul style="list-style-type: none"> <li>Pie cut corner hinge</li> </ul>				58
90°		<b>Flap hinge</b> <ul style="list-style-type: none"> <li>For flap thickness up to 20mm</li> <li>3-dimensional adjustment</li> </ul>				60
180°		<b>Glass door hinges</b> <ul style="list-style-type: none"> <li>No bore glass door</li> </ul>				61
		<b>Machinery GRASS PRO 1</b>				62

# Features and Benefits

## Nexis

### Features



- Opening angles from 95° to 170°
- Tool-free Soft-close option
- Combination drilling patterns for Impresso
- Specialty applications for angled and pie cut doors
- Tipmatic options are available

**Depth adjustment (+3/-1mm)**  
via hinge arm for standard base plate

**Depth adjustment (+3/-1mm)**  
via cam base plate

**Ergonomic clip**  
mounts with a soft but audible click

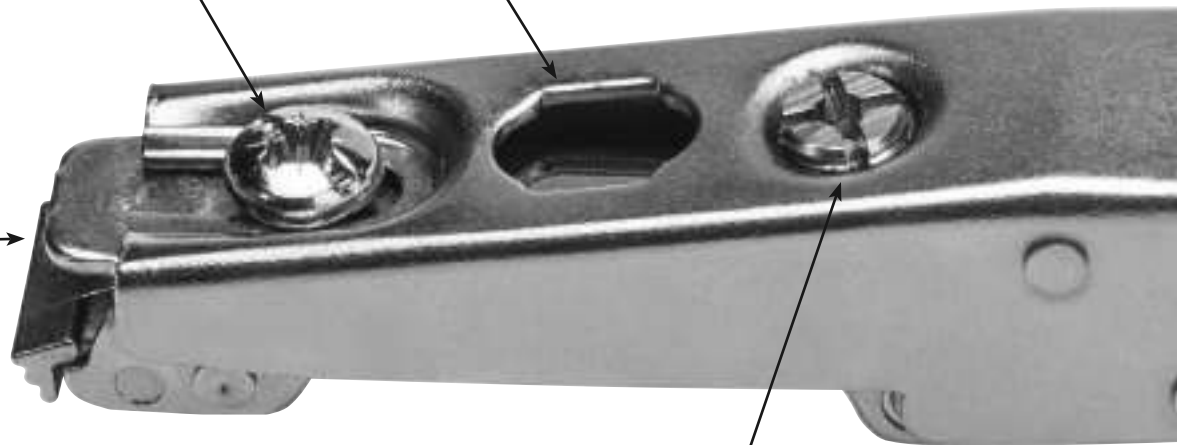

**Side Adjustment (+1/-3mm)**  
via hinge arm

**Height adjustment (±2mm)**  
via cam base plate

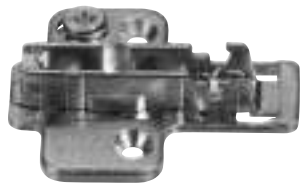

**Tool-free Soft-close option**  
cushion control for a slow gentle stop

**Features**

- 3-dimensional adjustment with suitable base plate
  - Depth adjustment  $\pm 3/-1$ mm
  - Height adjustment  $\pm 2$ mm
  - Side adjustment  $\pm 1/-3$ mm
- For face frame or frameless cabinets
- Impresso for tool-free application
- 42mm, 45mm, and 48mm boring patterns

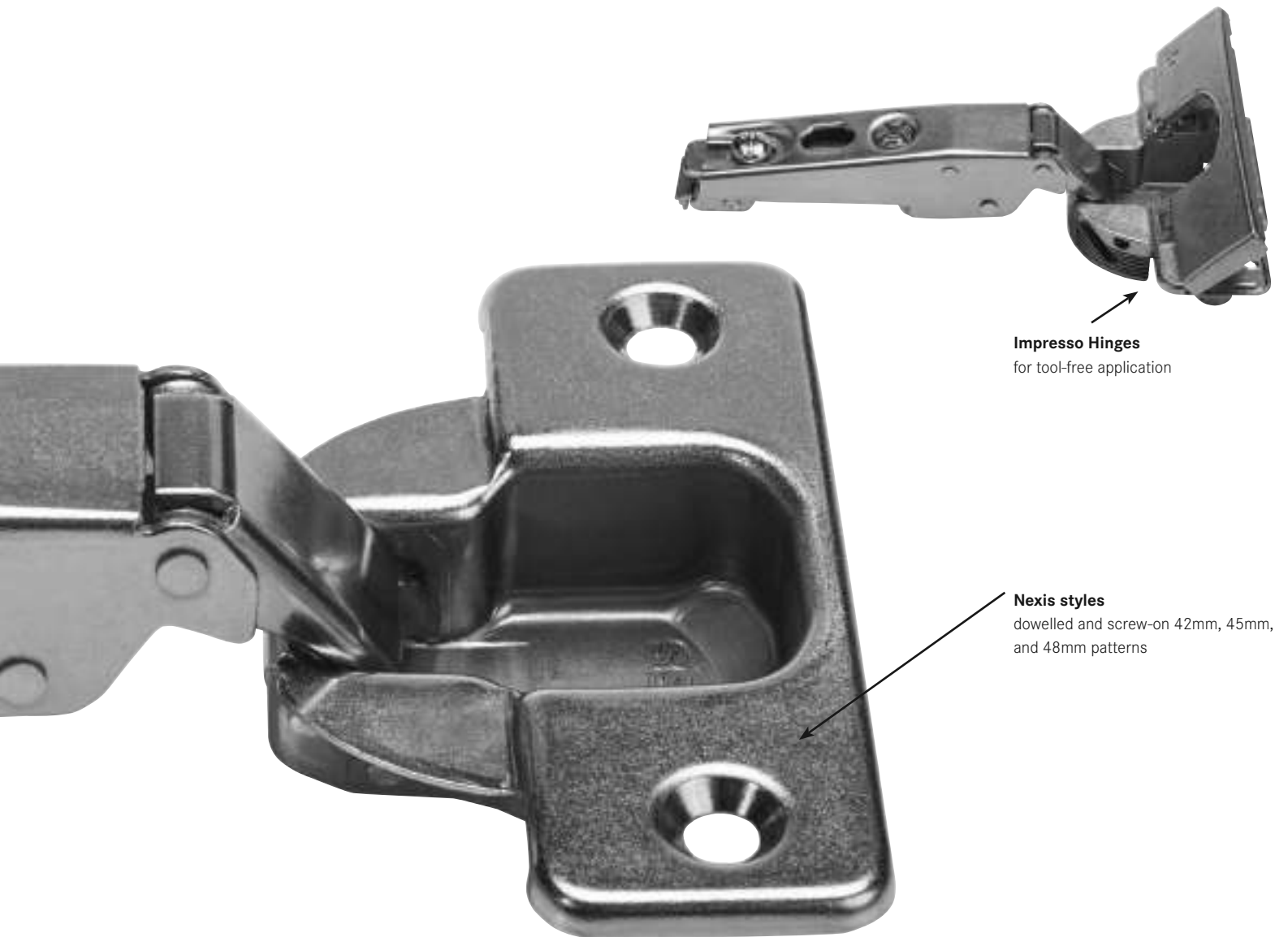

# Technical Information

## Nexis

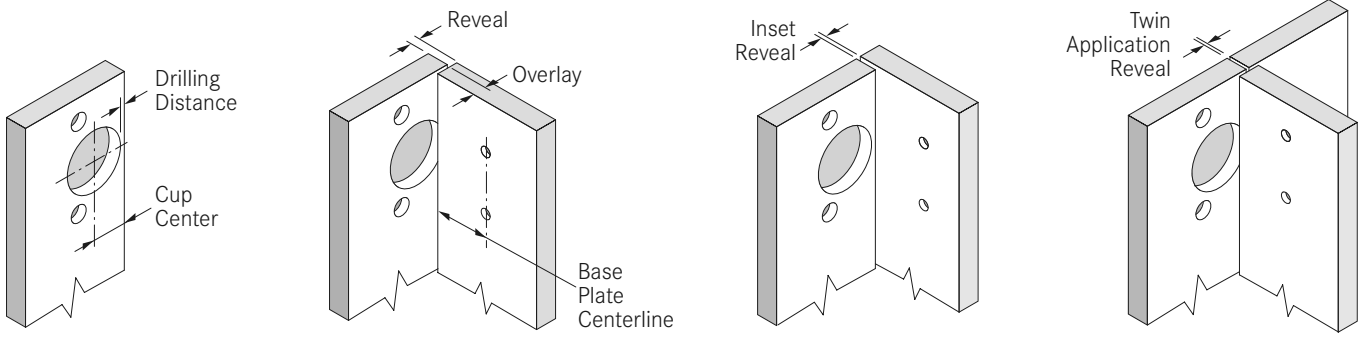

### Number of Hinges per Door

The number of hinges is determined by the door height, door weight, quality of the material and the fixing of the cup and base plate.

The load and height data refer to 24" standard door widths.

The table refers to hinges with and without integrated dampers. Grass strongly recommends a trial mount for all hinges and base plates.

Attach base plates using all available screw holes.

Example:  
For doors measuring 56" x 24" and weighing 19 lbs., Grass recommends the installation of 3 hinges.

Note: The distance between the top and bottom hinge must be greater than the width of the door.

The **Nexis** hinge meets and exceeds the minimum requirements of ANSI/BHMA A156.9 Standard.

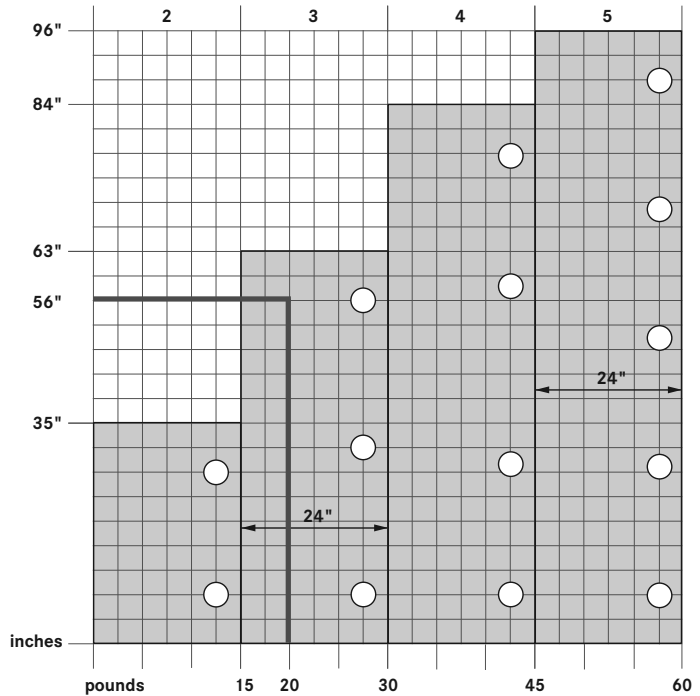

### Nexis Drilling Patterns

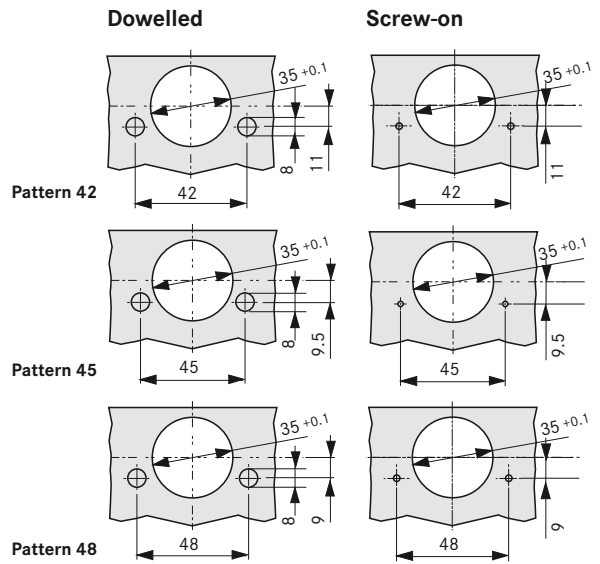

### Nexis Impresso Drilling Patterns

**Impresso 42/45** hinges accommodate cup drilling patterns of both 42mm and 45mm.  
**Impresso 45/48** hinges accommodate cup drilling patterns of both 45mm and 48mm.

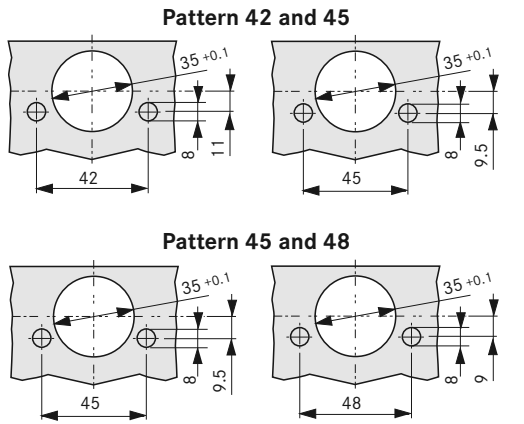



## Adjustments

The options for height adjustment depend on the type of base plate. All adjustments can be made independent of one another.

For depth adjustment, select base plates have cam adjustment access through the hinge arm.

Use a #2 POZI drive screwdriver for hinge adjustments.

**Attach base plates using all available screw holes.**

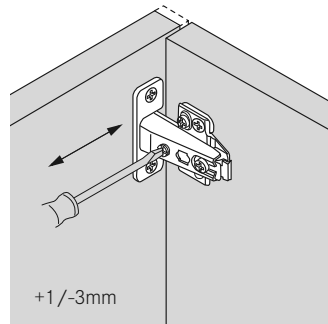

Side adjustment

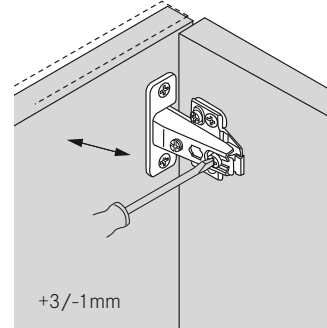

Depth adjustment

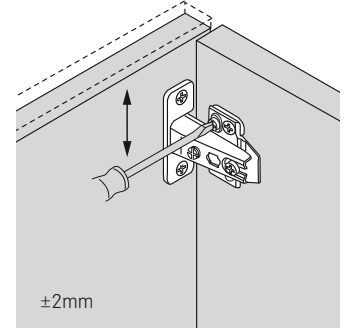

Height adjustment

## Reveal

### Full Overlay Door

### Half Overlay Door

### Inset Door

The reveal (R) is the distance required between two doors or between the door and side wall of the cabinet to allow sufficient space for opening the door. The required reveal width (R) depends on the thickness of the door.

Most cabinet makers prefer a reveal (R) of between 3mm and 6mm.

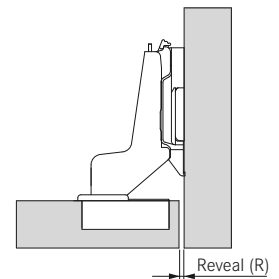
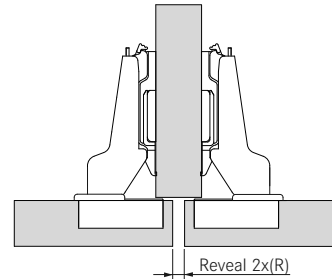
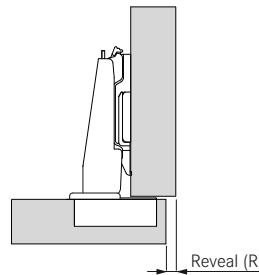

## Reveal for Overlay and Half Overlay Door

The table shows the reveal necessary between two doors or between door and side wall to allow enough space for opening the door.

### Example:

For a door thickness of 18mm and a drilling distance of 6mm, a gap of 0.2mm is needed.

Door thickness (DT)	Drilling Distance (DD)				Reveal min. (R)
	3	4	5	6	
16	0.1	0.1	0.1	0.1	
18	0.2	0.2	0.2	0.2	
19	0.3	0.3	0.3	0.3	
20	0.4	0.4	0.4	0.4	
22	0.7	0.7	0.7	0.7	
24	1.0	1.0	1.0	1.0	
26	1.4	1.4	1.4	1.4	
28	1.9	1.9	1.9	1.9	
30	3.8	2.9	2.6	2.5	

## Reveal for Inset Door

The table shows the minimum reveal for an inset door, depending on the drilling distance and base plate height.

**Example:** A drilling distance of 4mm results from using a base plate with height 04 in a reveal of 2mm.

Minimum Reveal (R)	Drilling Distance (DD)				Base Plate Height (BPH)
	3	4	5	6	
0		2		4	
1	2		4		
2		4			

### Note:

Reveal dimensions were determined with a door edge radius of 1mm. Hinge dimensions and calculation of gap with factory setting.

### IMPORTANT

To determine the correct application Grass strongly recommends a trial mounting for all hinges and base plates.

# Technical Information

## Nexis

### Minimum Gap      Drilling Distance

The **Minimum gap** is the gap between the closed door and the front of the cabinet.

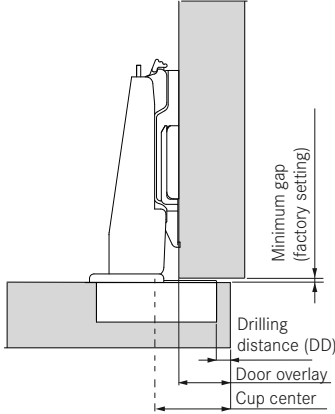

Drilling Distance (DD)		Cup Center (CC)	
1/8"	3	13/16"	20.5
5/32"	4	27/32"	21.5
3/16"	5	7/8"	22.5
1/4"	6	15/16"	23.5
9/32"	7	31/32"	24.5
5/16"	8	1"	25.5

The **drilling distance (DD)** is the distance between the edge of the door and the edge of the cup hole.

The **cup center** is the distance of the cup drilling distance plus 1/2 of the cup diameter.

**Example:**

For a door thickness (DT) of 26mm and a drilling distance (DD) of 6mm a minimum gap of 0.7mm is needed.

		Drilling Distance (DD)					
		3	4	5	6		
Door Thickness (DT)	16	0.5	0.5	0.5	0.5		
	18	0.5	0.5	0.5	0.5		
	19	0.5	0.5	0.5	0.5		
	20	0.0	0.0	0.0	0.5		
	22	1.4	2.4	3.4	0.5		
	24	0.5	0.5	0.5	0.5		
	26	0.5	0.5	0.5	0.7		
	28	0.5	0.5	0.5	0.9		
	30	0.5	0.5	1.1	1.1		
							Minimum gap

### Door Overlay

The **door overlay** is the part of the cabinet side wall or face frame that is covered by the door on the hinge side.

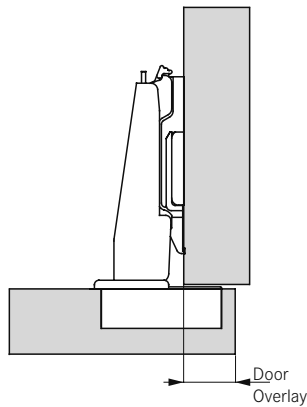

**Example:**

For a hinge with a cranking of 00, a base plate height (BPH) of 2mm, and a drilling distance (DD) of 4mm, the door overlay is 15mm.

		Drilling Distance (DD)				
		*3	4	5	6	7
Door Overlay	20					0
	19				0	
	18			0		2
	17		0		2	
	16	0		2		4
	15		2		4	
	14	2		4		
	13		4			
	12	4				
			Base Plate Height (BPH)			

### Door Edge Protrusion

The **door edge protrusion** is the amount by which the edge of the open door protrudes into the opening and varies depending on the type of hinge and method of fixing. It is stated on the respective catalog page and refers to the stated base plate for the factory setting. It can be changed by changing the height of the base plate and adjusting the lateral adjustment.

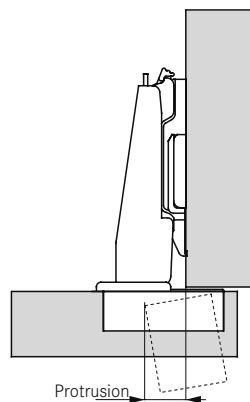

## Door Positions

### Achieve overlay with hinge cranking

### Or Achieve overlay with base plate

#### Full Overlay (Cranking 00)

#### Full Overlay

The cup overlay (factory setting) plus drilling distance determine the door overlay. Dimensions can be found in a table on the respective page of the catalog.

Using a hinge with a cranking of 00 and a base plate height (BPH) 00

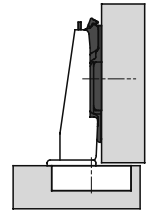
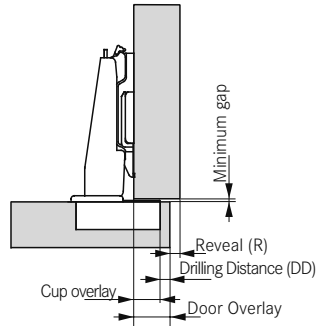

#### Half Overlay (Cranking 08)

#### Half Overlay

The cup overlay (factory setting) plus drilling distance determine the door overlay. Dimensions can be found in a table on the respective page of the catalog.

Using a hinge with a cranking of 00 and a base plate height (BPH) 8.0

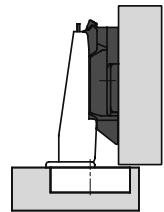
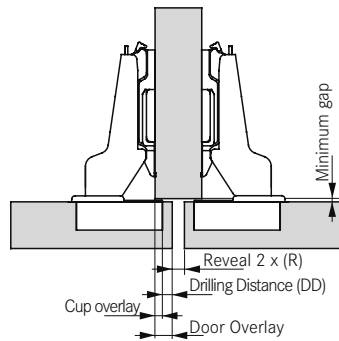

#### Inset (Cranking 15)

#### Inset

There is no door overlay. The reveal between the side of the cabinet and the door depends on the base plate height (BPH) and the drilling distance (DD). Dimensions can be found in a table on the respective page of the catalog.

Using a hinge with a cranking of 00 and a base plate height (BPH) 18

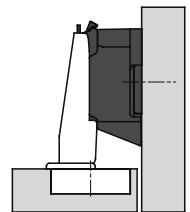
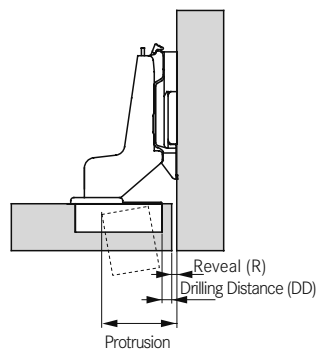

# Insertion Instructions

## Nexis 85° Reduction Clip

### 85° Reduction Clip



Description	Material	Item No.	PU
85° angle reduction clip	Black plastic	641.000.10.9862	1000

**Note:** Nexis 85° Reduction Clip for standard 110° and 125° hinges

PU - Packaging unit

### Instructions for 85° Angle Reduction Clip

Begin with hinge in the open position and not mounted on door.

With needle-nosed pliers grip sides of clip.



Insert clip over the roll pin.



Push clip in as you start to close hinge.  
Clip will snap into place.

Hinge opening angle is reduced to 85.



# Testing Information

## Nexis

### Functional Test

#### Static load - vertical

Additional load: 44 pounds (20 kg)

Opening angle: max.  $-10^{\circ}$

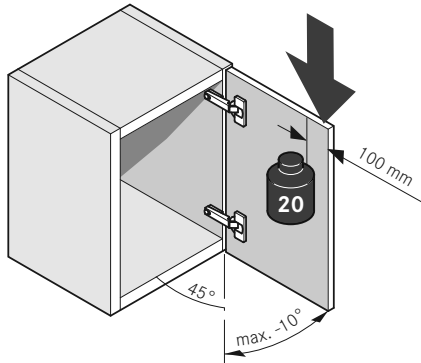

#### Static load - horizontal

Force: 40 N

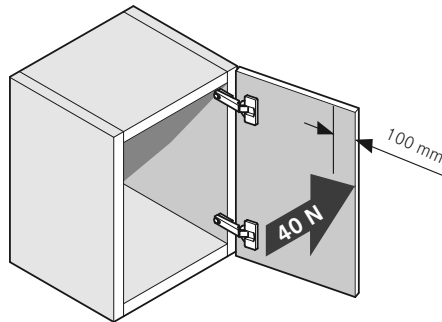

#### Endurance Test

Opening angle: max.  $-5^{\circ}$

Open and close movements: 100,000

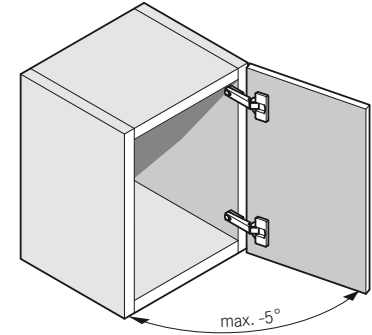

### Overload Testing

#### Vertical

Additional load: 66 pounds (30 kg)

Opening angle: max.  $-10^{\circ}$

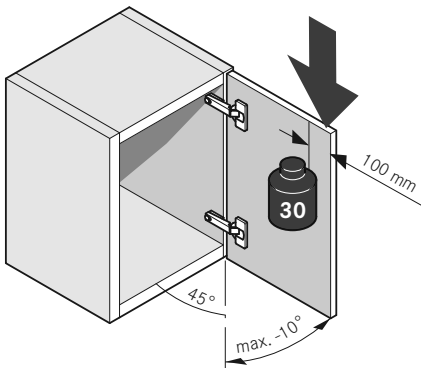

#### Horizontal

Force: 80 N

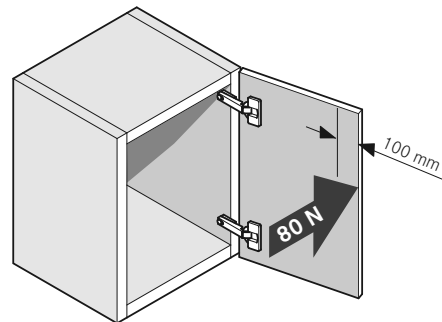

#### Test door

Weight approx. 11.5 pounds (5.2 kg)

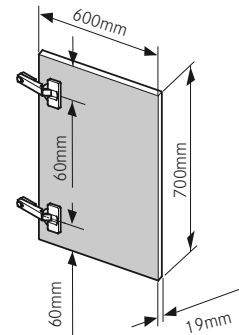

### Salt Spray and Humidity Test

Based on DIN ISO 9227 and DIN 6270-2

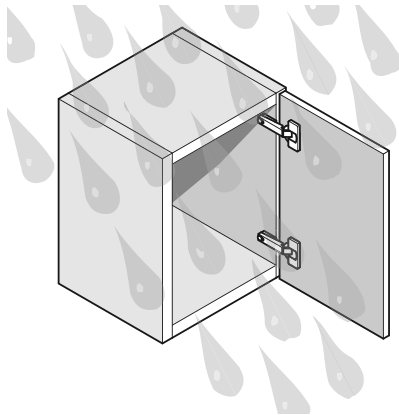

# Nexis 110

## 110° hinge for standard doors



- 3-dimensional adjustment with suitable base plate
- Soft-close compatible
- Shallow cup depth
  - Nexis Impresso 11.5mm
  - Nexis 11mm
- Accommodates overlays up to 20mm (25/32")
- Self-close or free-swing hinges available
- For face frame and frameless cabinets
- Combination drilling pattern for Nexis Impresso

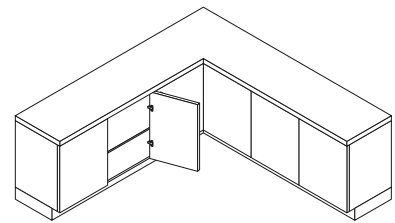

Nexis 110 Opening Angle 110°		Impresso				Screw-On		Dowelled	
------------------------------	--	----------	--	--	--	----------	--	----------	--

Full Overlay	Cranking 00	Pattern	Type	Item No.	PU	Pattern	Type	Item No.	Item No.	PU
	<b>Nexis Impresso:</b>	42/45	Self-close	138.622.50.0015	125	42	Self-close	138.322.73.0015	138.322.74.0015	250
	Hinge cup: diecast, nickel-plated	45/48	Self-close	146.622.35.0015	125	45	Self-close	148.322.53.0015	148.322.54.0015	250
	Hinge arm: steel, nickel-plated					45	Free-swing	147.322.53.0015	147.322.54.0015	250
	<b>Nexis :</b>					48	Self-close	146.322.53.0015	146.322.54.0015	250

Hinge cup: steel, nickel-plated  
Hinge arm: steel, nickel-plated

Half Overlay	Cranking 08	Pattern	Type	Item No.	PU	Pattern	Type	Item No.	Item No.	PU
	<b>Nexis Impresso:</b>	42/45	Self-close	138.622.50.0815	125	42	Self-close	138.322.73.0815	138.322.74.0815	250
	Hinge cup: diecast, nickel-plated	45/48	Self-close	146.622.35.0815	125	45	Self-close	148.322.53.0815	148.322.54.0815	250
	Hinge arm: steel, nickel-plated					48	Self-close	146.322.53.0815	146.322.54.0815	250
	<b>Nexis :</b>									

Hinge cup: steel, nickel-plated  
Hinge arm: steel, nickel-plated

Inset	Cranking 15	Pattern	Type	Item No.	PU	Pattern	Type	Item No.	Item No.	PU
	<b>Nexis Impresso:</b>	42/45	Self-close	138.604.51.1515	125	42	Self-close	-	138.304.74.1515	250
	Hinge cup: diecast, nickel-plated	<b>Note: Opening angle 100°</b>				45	Self-close	-	148.304.54.1515	250
	Hinge arm: steel, nickel-plated					48	Self-close	146.304.55.1515	146.304.56.1515	250
	<b>Nexis :</b>									

Hinge cup: steel, nickel-plated  
Hinge arm: steel, nickel-plated

Cover Caps	Cranking 00	Item No.	PU	85° Angle Reduction Clip	Item No.	PU
	Steel, nickel-plated	514.300.21.0215	1000		Black plastic	641.000.10.9862
	Black plastic	514.000.22.9662	1000			

Cover Caps	Cranking 08 and 15	Item No.	PU	Wood Screw, Nickel-plated	Item No.	PU
	Black plastic	514.000.22.9662	1000		#6 x 5/8" FHP, NI	81001-43
						500

PU - Packaging unit

**Full Overlay      Half Overlay      Inset**

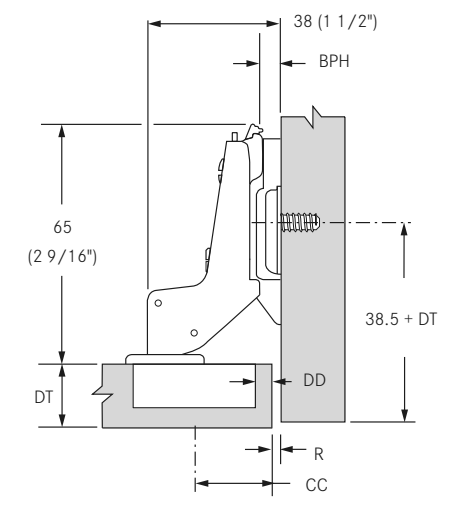
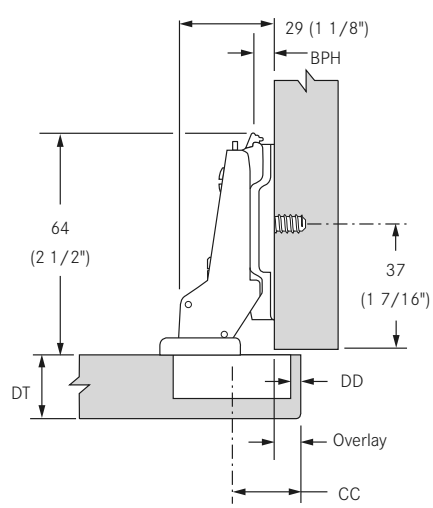
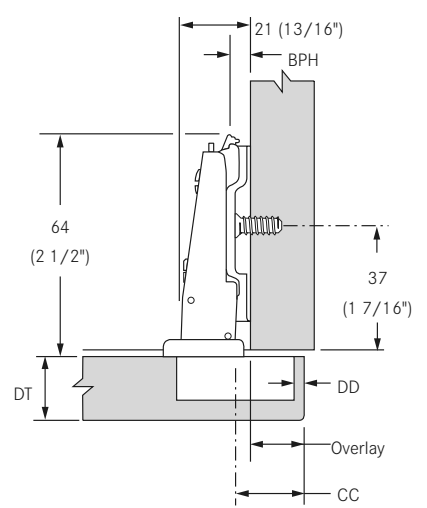

Drawings show Nexis with a base plate, (BPH) 02.

Drawings show Nexis with a base plate, (BPH) 02.

Drawings show Nexis with a base plate, (BPH) 04.

Door Overlay	Drilling Distance (DD)					
	*3	4	5	6	7	
20					0	
19				0		
18			0		2	
17		0		2		
16	0		2		4	
15		2		4		
14	2		4			
13		4				
12	4					
	Base Plate Height (BPH)					

Door Overlay	Drilling Distance (DD)					
	*3	4	5	6	7	
12					0	
11				0		
10			0		2	
9		0		2		
8	0		2		4	
7		2		4		
6	2		4			
5		4				
4	4					
	Base Plate Height (BPH)					

Reveal (R)	Drilling Distance (DD)					
	*3	4	5	6	7	
0		2		4		
1	2		4			
2						
	Base Plate Height (BPH)					

**Note:**  
\*3mm drilling distance for Nexis only  
A door stop is needed to prevent over close.

**Minimum Gaps      Reveal**

Door Thickness (DT)	Drilling Distance (DD)					
	*3	4	5	6	7	
16	0.5	0.6	1.6	2.6	3.6	
18	0.5	1.2	2.2	3.2	4.2	
19	0.5	1.5	2.5	3.5	4.5	
20	0.8	1.8	2.8	3.8	4.8	
22	1.4	2.4	3.4	4.4	5.4	
	Minimum Gap					

Door Thickness (DT)	Drilling Distance (DD)					
	*3	4	5	6	7	
16	0.5	0.5	0.5	0.5	0.5	
18	1.0	1.0	1.0	1.0	1.0	
19	1.2	1.2	1.2	1.2	1.2	
20	2.2	1.5	1.5	1.5	1.5	
22	4.7	3.7	2.8	2.1	2.1	
	Reveal Min. (R)					

**Note:** Reveal dimensions were determined with an edge radius (of the door) of 1mm. Hinge dimensions and reveal calculation based on factory setting.

**IMPORTANT**  
To determine the correct application Grass strongly recommends a trial mounting for all hinges and base plates.

Door Thickness (DT)	Drilling Distance (DD)					
	*3	4	5	6	7	
16	0.6	0.6	0.6	0.6	0.6	
18	0.9	0.9	0.9	0.9	0.9	
19	1.1	1.1	1.1	1.1	1.1	
20	1.4	1.4	1.4	1.4	1.4	
22	1.9	1.9	1.9	1.9	1.9	
24	2.5	2.5	2.5	2.5	2.5	
	Reveal Min. (R)					

**Legend      Cup Dimensions**

- BPH = Base Plate Height
- CC = Center Cup
- DD = Drilling Distance
- DT = Door Thickness
- R = Reveal

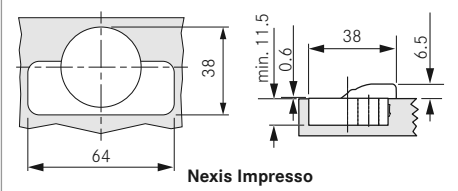
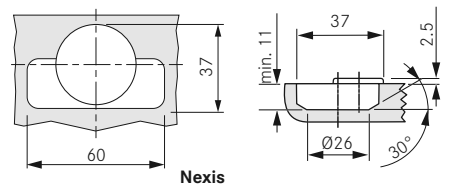

# Nexis 125

## 125° hinge for standard doors



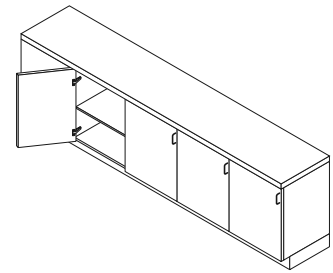

- 3-dimensional adjustment with suitable base plate
- Soft-close compatible
- Accommodates overlays up to 19mm (3/4")
- For door thickness up to 19mm (3/4")
- Alternative solution for wide angle application
- Self-close hinges available
- For face frame and frameless cabinets
- Combination drilling pattern for Nexis Impresso



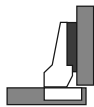

Nexis 125 Opening Angle 125°		Impresso				Screw-On			Dowelled	
------------------------------	--	----------	--	--	--	----------	--	--	----------	--

Full Overlay	Cranking 00	Pattern	Type	Item No.	PU	Pattern	Type	Item No.	Item No.	PU
 <p><b>Nexis Impresso:</b> Hinge cup: diecast, nickel-plated Hinge arm: steel, nickel-plated</p> <p><b>Nexis :</b> Hinge cup: steel, nickel-plated Hinge arm: steel, nickel-plated</p>		42/45	Self-close	138.629.50.0015	125	42	Self-close	138.329.73.0015	138.329.74.0015	250
		45/48	Self-close	146.629.35.0015	125	45	Self-close	148.329.31.0015	148.329.32.0015	250
						48	Self-close	146.329.55.0015	146.329.56.0015	250

Half Overlay	Cranking 08	Pattern	Type	Item No.	PU	Pattern	Type	Item No.	Item No.	PU
 <p><b>Nexis Impresso:</b> Hinge cup: diecast, nickel-plated Hinge arm: steel, nickel-plated</p> <p><b>Nexis :</b> Hinge cup: steel, nickel-plated Hinge arm: steel, nickel-plated</p>						42	Self-close	138.329.73.0815	138.329.74.0815	250
						48	Self-close	146.329.55.0815	-	250

Cover Caps	Cranking 00	Item No.	PU	85° Angle Reduction Clip	Item No.	PU
	Steel, nickel-plated	514.300.21.0215	1000		Black plastic	641.000.10.9862
	Black plastic	514.000.22.9662	1000			

Cover Caps	Cranking 08 and 15	Item No.	PU	Wood Screw, Nickel-plated	Item No.	PU
	Black plastic	514.000.22.9662	1000		#6 x 5/8" FHP, NI	81001-43

PU - Packaging unit



### Full Overlay

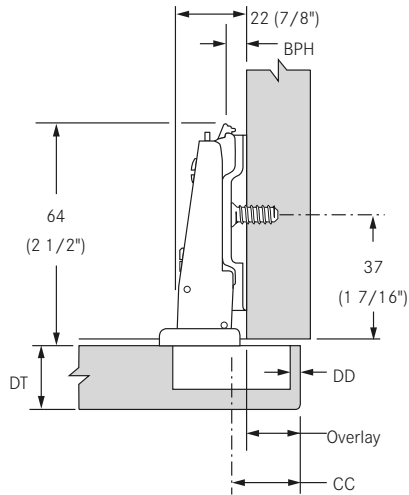

Drawings show Nexis with a base plate, (BPH) 02.

Door Overlay	Drilling Distance (DD)				
	*3	4	5	6	
19				0	
18			0		
17		0		2	
16	0		2		
15		2		4	
14	2		4		
13		4			
12	4				
	Base Plate Height (BPH)				

### Half Overlay

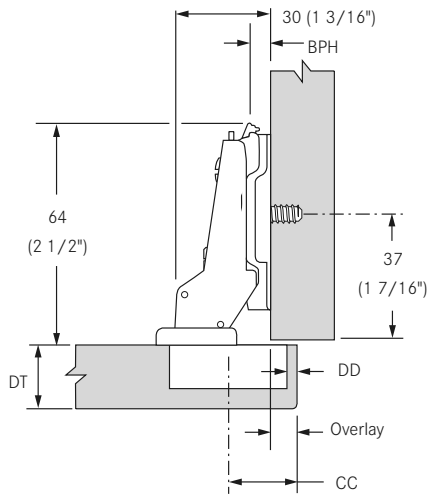

Drawings show Nexis with a base plate, (BPH) 02.

Door Overlay	Drilling Distance (DD)				
	*3	4	5	6	
9		0		2	
8	0		2		
7		2		4	
6	2		4		
5		4			
4	4				
	Base Plate Height (BPH)				

**Note:**  
\*3mm drilling distance for Nexis only

### Minimum Gaps

Door Thickness (DT)	Drilling Distance (DD)				
	*3	4	5	6	
16	0.5	0.6	1.6	2.6	
18	1.3	2.1	2.9	3.7	
19	1.9	2.7	3.5	4.3	
20	2.4	3.2	4.0	4.8	
	Minimum Gap				

The minimum gap is the gap between the closed door and the front of the cabinet.

### Reveal

Door Thickness (DT)	Drilling Distance (DD)				
	*3	4	5	6	
16	1.9	1.9	1.9	1.9	
18	2.8	2.6	2.5	2.5	
19	4.6	3.6	3.0	2.9	
20	6.5	5.5	4.5	3.5	
	Reveal Min. (R)				

**Note:** Reveal dimensions were determined with an edge radius (of the door) of 1mm. Hinge dimensions and reveal calculation based on factory setting.

#### IMPORTANT

To determine the correct application Grass strongly recommends a trial mounting for all hinges and base plates.

### Legend

- BPH = Base Plate Height
- CC = Center Cup
- DD = Drilling Distance
- DT = Door Thickness
- R = Reveal

### Cup Dimensions

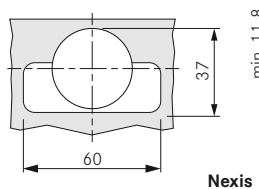

Nexis

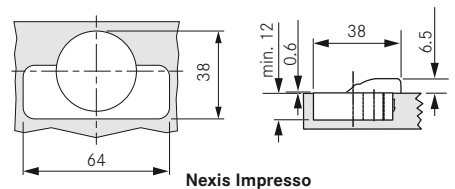

Nexis Impresso

# Nexis 170

## 170° wide-angle hinge



- 3-dimensional adjustment with suitable base plate
- Soft-close compatible
- Accommodates overlays up to 19mm (3/4")
- Shallow cup depth (11mm) for Nexis and Nexis Impresso
- Zero protrusion when door opened 90°
- Finger protection
- Self-close or free-swing hinges available
- For face frame and frameless cabinets
- Combination drilling pattern for Nexis Impresso

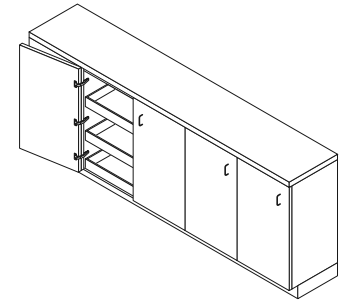

Nexis 170 Opening Angle 170°		Impresso				Screw-On		Dowelled	
------------------------------	--	----------	--	--	--	----------	--	----------	--

Full Overlay	Cranking 00	Pattern	Type	Item No.	PU	Pattern	Type	Item No.	Item No.	PU	
	<b>Nexis Impresso:</b>	42/45	Self-close	138.765.65.0015	50	42	Self-close	138.765.73.0015	138.765.74.0015	50	
		Hinge cup: diecast, nickel-plated	45/48	Self-close	146.765.35.0015	50	45	Self-close	148.765.53.0015	148.765.54.0015	50
	<b>Nexis :</b>	Hinge arm: diecast, nickel-plated	45	Free-swing	147.765.53.0015	-	48	Self-close	146.765.53.0015	146.765.54.0015	50
		Hinge cup: diecast, nickel-plated									

Half Overlay	Cranking 08	Pattern	Type	Item No.	PU	Pattern	Type	Item No.	Item No.	PU	
	<b>Nexis Impresso:</b>	-	-	-	-	42	Self-close	138.765.73.0815	138.765.74.0815	50	
		Hinge cup: diecast, nickel-plated	45/48	Self-close	146.765.35.0815	50	45	Self-close	148.765.53.0815	148.765.54.0815	50
	<b>Nexis :</b>	Hinge arm: diecast, nickel-plated					48	Self-close	-	146.765.54.0815	50
		Hinge cup: diecast, nickel-plated									

120° Angle Reduction Clip	Item No.	PU	Wood Screw, Nickel-plated	Item No.	PU
<p>Black plastic. Opening angle reduction to 120°. Prevents doors from bumping with the cabinet side in inset applications and mitered corner applications.</p>	641.000.09.9862	1000	<p>#6 x 5/8" FHP, NI</p>	81001-43	500

### Zero Protrusion Special Applications with Angle Reduction Clip

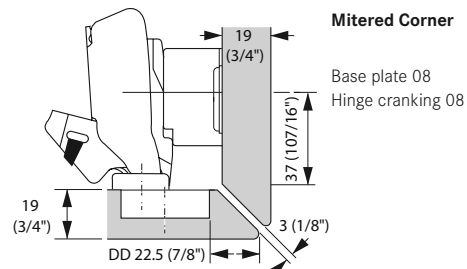
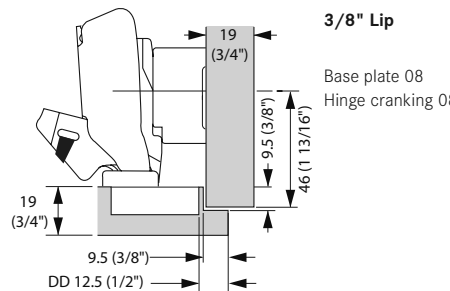
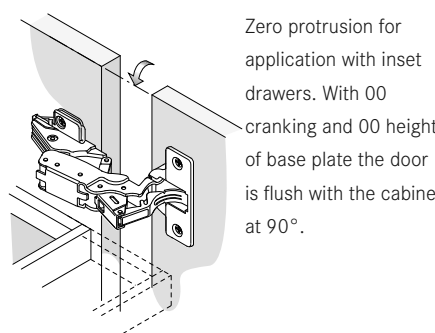

PU - Packaging unit

**Full Overlay      Half Overlay      Inset**

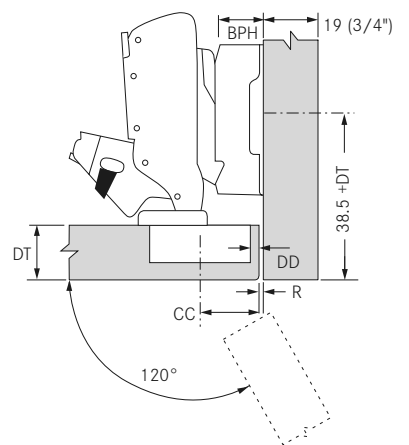
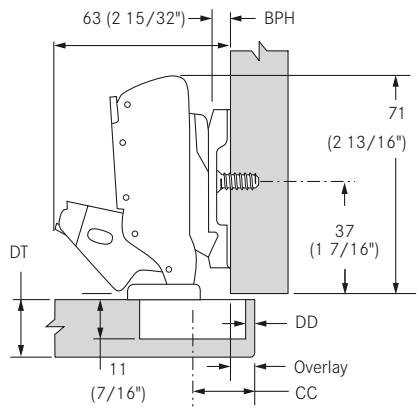
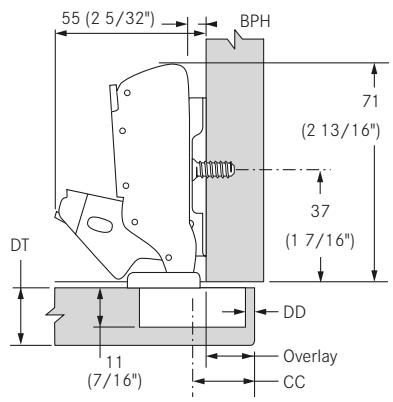

Drawings show Nexis with a base plate, **(BPH) 02**.

Drawings show Nexis with a base plate, **(BPH) 02**.

Drawings show Nexis with a base plate, **(BPH) 08**, and angle reduction clip

Door Overlay	Drilling Distance (DD)					
	3	4	5	6	7	8
21						0
20					0	
19				0		2
18			0		2	
17		0		2		4
16	0		2		4	
15		2		4		
14	2		4			
13		4				
12	4					
	Base Plate Height (BPH)					

Door Overlay	Drilling Distance (DD)					
	3	4	5	6	7	8
13						0
12					0	
11				0		2
10			0		2	
9		0		2		4
8	0		2		4	
7		2		4		
6	2		4			
5		4				
	Base Plate Height (BPH)					

Reveal (R)	Drilling Distance (DD)			
	3	4	5	6
0	8			
1		8		
2			8	
3				8
	Base Plate Height (BPH)			

**Note:**  
Drilling distance 3mm for Nexis and Nexis Impresso  
A door stop is needed to prevent over close.

**Minimum Gaps**

Door Thickness (DT)	Drilling Distance (DD)					
	3	4	5	6	8	10
16	0.7	0.7	0.7	0.7	0.7	0.7
18	0.7	0.7	0.7	0.7	0.7	0.7
19	0.7	0.7	0.7	0.7	0.7	0.7
20	0.7	0.7	0.7	0.7	0.7	0.7
22	0.7	0.7	0.7	0.7	0.7	0.7
23	0.7	0.7	0.7	0.7	0.7	0.7
24	0.7	0.7	0.7	0.7	0.7	0.7
25	0.7	0.7	0.7	0.7	0.7	0.7
26	0.7	0.7	0.7	0.7	0.7	0.7
	Minimum Gap					

The minimum gap is the gap between the closed door and the front of the cabinet.

**Reveal**

Door Thickness (DT)	Drilling Distance (DD)					
	3	4	5	6	7	8
16	0.0	0.0	0.0	0.0	0.0	0.0
18	0.0	0.0	0.0	0.0	0.0	0.0
19	0.0	0.0	0.0	0.0	0.0	0.0
20	0.0	0.0	0.0	0.0	0.0	0.0
22	0.0	0.0	0.0	0.0	0.0	0.0
23	0.0	0.0	0.0	0.0	0.0	0.0
24	0.0	0.0	0.0	0.5	1.8	2.0
25	6.5	6.5	6.0	5.5	4.8	6.5
26	10.5	9.5	8.5	7.5	6.5	5.5
	Reveal Min. (R)					

**Note:** Reveal dimensions were determined with an edge radius (of the door) of 1mm. Hinge dimensions and reveal calculation based on factory setting.

**IMPORTANT**  
To determine the correct application Grass strongly recommends a trial mounting for all hinges and base plates.

**Legend**

- BPH = Base Plate Height
- CC = Center Cup
- DD = Drilling Distance
- DT = Door Thickness
- R = Reveal

**Cup Dimensions**

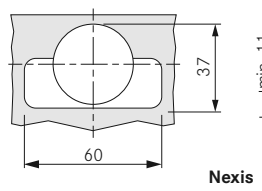

**Nexis**

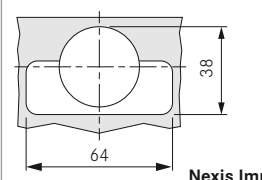

**Nexis Impresso**

# Nexis 95

## 95° hinge for thick or profile doors



- 3-dimensional adjustment with suitable base plate
- Soft-close compatible
- Accommodates overlays up to 19mm (3/4")
- Minimal gap dimensions on thick doors
- For door thickness up to 30mm (1 3/16")
- Self-close or free-swing hinges available
- For face frame and frameless cabinets

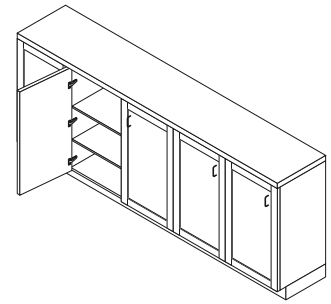

Nexis 95	Opening Angle 95°	Screw-On			
----------	-------------------	----------	--	--	--

Full Overlay	Cranking 00	Pattern	Type	Item No.	PU
	Hinge cup: steel, nickel-plated Hinge arm: steel, nickel-plated	42	Self-close	138.305.73.0015	250
		45	Self-close	148.305.53.0015	250
		48	Self-close	146.305.53.0015	250

Half Overlay	Cranking 08	Pattern	Type	Item No.	PU
	Hinge cup: steel, nickel-plated Hinge arm: steel, nickel-plated	48	Self-close	146.305.53.0815	250
		48	Free-swing	145.305.53.0815	250

Inset	Cranking 15	Pattern	Type	Item No.	PU
	Hinge cup: steel, nickel-plated Hinge arm: steel, nickel-plated	42	Self-close	138.305.73.1515	250
		48	Self-close	146.305.53.1515	250

Cover Caps	Cranking 00	Item No.	PU
	Steel, nickel-plated	514.300.21.0215	1000
	Black plastic	514.000.22.9662	1000

Cover Caps	Cranking 08 and 15	Item No.	PU	Wood Screw, Nickel-plated	Item No.	PU	
	Black plastic	514.000.22.9662	1000		#6 x 5/8" FHP, NI	81001-43	500

PU - Packaging unit

**Full Overlay      Half Overlay      Inset**

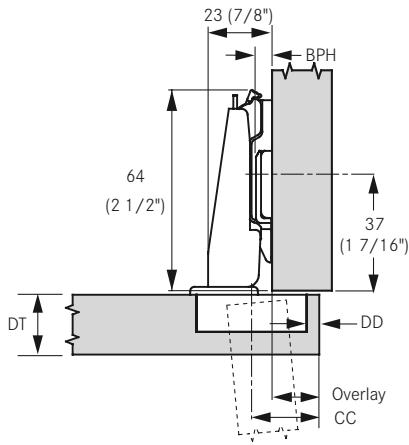

Drawings show Nexis with a base plate, (BPH) 02.

Door Overlay	Drilling Distance (DD)				
	*3	4	5	6	
19				0	
18			0		
17		0		2	
16	0		2		
15		2		4	
14	2		4		
13		4			
12	4				
	Base Plate Height (BPH)				

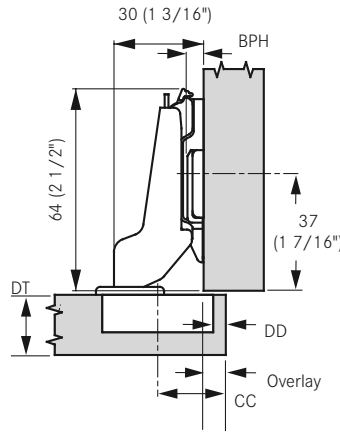

Drawings show Nexis with a base plate, (BPH) 02.

Door Overlay	Drilling Distance (DD)				
	*3	4	5	6	
11				0	
10			0		
9		0		2	
8	0		2		
7		2		4	
6	2		4		
5		4			
4	4				
	Base Plate Height (BPH)				

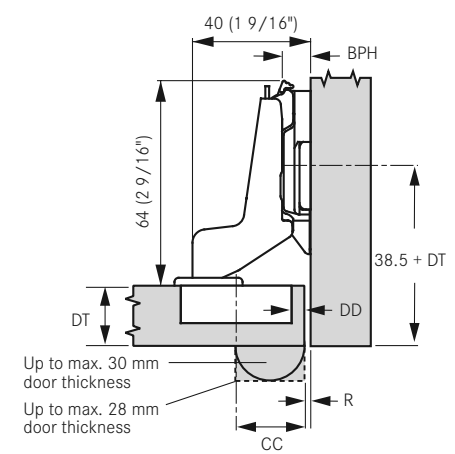

Drawings show Nexis with a base plate, (BPH) 04.

Reveal (R)	Drilling Distance (DD)			
	*3	4	5	6
0		2		4
1	2		4	
2		4		
	Base Plate Height (BPH)			

**Note:**  
\*3mm drilling distance for Nexis only  
A door stop is needed to prevent over close.

**Minimum Gaps      Reveal**

Door Thickness (DT)	Drilling Distance (DD)			
	3	4	5	6
16	0.5	0.5	0.5	0.5
18	0.5	0.5	0.5	0.5
19	0.5	0.5	0.5	0.5
20	0.5	0.5	0.5	0.5
22	0.5	0.5	0.5	0.5
23	0.5	0.5	0.5	0.5
24	0.5	0.5	0.5	0.5
26	0.5	0.5	0.5	0.7
28	0.5	0.5	0.5	0.9
30	0.5	0.5	1.1	1.1
	Minimum Gap			

The minimum gap is the gap between the closed door and the front of the cabinet.

Door Thickness (DT)	Drilling Distance (DD)			
	3	4	5	6
16	0.1	0.1	0.1	0.1
18	0.2	0.2	0.2	0.2
19	0.3	0.3	0.3	0.3
20	0.4	0.4	0.4	0.4
22	0.7	0.7	0.7	0.7
24	1.0	1.0	1.0	1.0
26	1.4	1.4	1.4	1.4
28	1.9	1.9	1.9	1.9
30	3.8	2.9	2.6	2.5
	Reveal Min. (R)			

**Note:** Reveal dimensions were determined with an edge radius (of the door) of 1mm. Hinge dimensions and reveal calculation based on factory setting.

**IMPORTANT**  
To determine the correct application Grass strongly recommends a trial mounting for all hinges and base plates.

**Legend      Cup Dimensions**

- BPH = Base Plate Height
- CC = Center Cup
- DD = Drilling Distance
- DT = Door Thickness
- R = Reveal

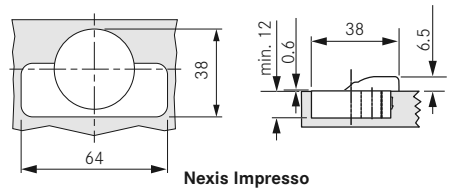
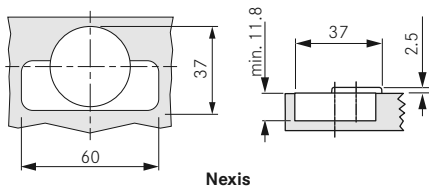

# Nexis 95/40

95° hinge with 40mm cup for profile doors



- 3-dimensional adjustment with suitable base plate
- Accommodates door overlays up to 23mm (7/8")
- Minimal gap dimensions on thick doors
- Excellent weight capacity for heavy profile doors
- For profile or frame doors up to 36mm thick
- Special spring mechanism ensures excellent closing force - even with large doors
- Self-close hinges available
- For face frame and frameless cabinets

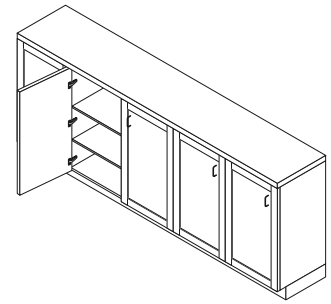

## Nexis 95/40 Opening Angle 95°



### Screw-On

Full overlay	Cranking 00	Pattern	Type	Item No.	PU
	Hinge cup: steel, nickel-plated; Hinge arm: steel, nickel-plated	48	Self-close	146.425.53.0015	125

Half overlay	Cranking 08	Pattern	Type	Item No.	PU
	Hinge cup: steel, nickel-plated; Hinge arm: steel, nickel-plated	48	Self-close	146.425.53.0815	125

Inset	Cranking 15	Pattern	Type	Item No.	PU
	Hinge cup: steel, nickel-plated; Hinge arm: steel, nickel-plated	48	Self-close	146.425.53.1515	125

Cover Caps	Cranking 00	Item No.	PU
	Steel, nickel-plated	514.300.21.0215	1000
	Black plastic	514.000.22.9662	1000

Cover Caps	Cranking 08 and 15	Item No.	PU	Wood Screw, Nickel-plated	Item No.	PU
	Black plastic	514.000.22.9662	1000	 #6 x 5/8" FHP, NI	81001-43	500

PU - Packaging unit

**Full Overlay      Half Overlay      Inset**

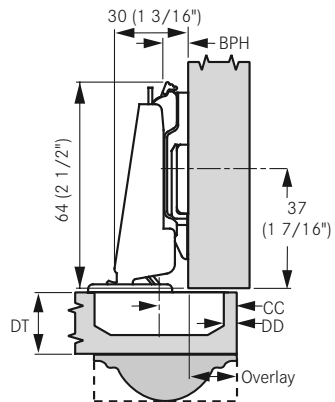

Drawings show Nexis with a base plate, (BPH) 02.

Door Overlay	Drilling Distance (DD)										
	3	4	5	6	7	8	9	10	11		
23									0	2	
22								0	2		
21						0	2				
20				0	2	4					
19			0	2	4						
18		0	2	4							
17	0	2	4								
16	0	2	4								
15	2	4									
14	2	4									
13	4										
	Base Plate Height (BPH)										

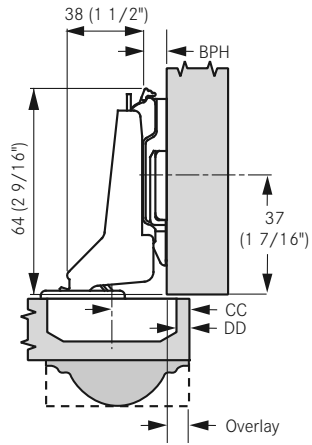

Drawings show Nexis with a base plate, (BPH) 02.

Door Overlay	Drilling Distance (DD)										
	3	4	5	6	7	8	9	10	11		
15									0	2	
14								0	2		
13						0	2				
12				0	2	4					
11			0	2	4						
10		0	2	4							
9	0	2	4								
8	0	2	4								
7	2	4									
6	2	4									
5	4										
	Base Plate Height (BPH)										

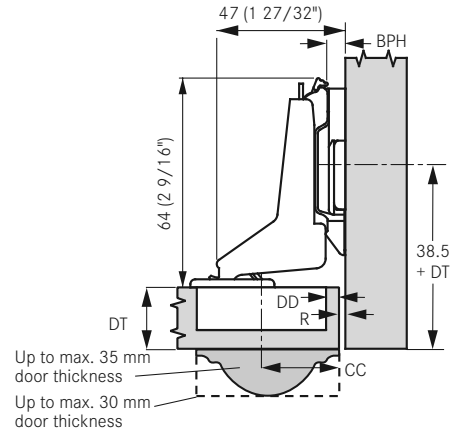

Drawings show Nexis with a base plate, (BPH) 04.

Reveal (R)	Drilling Distance (DD)					
	3	4	5	6		
0		2	4			
1	2		4			
2		4				
	Base Plate Height (BPH)					

**Note:**  
A door stop is needed to prevent over close.

**Minimum Gaps**

Door Thickness (DT)	Drilling Distance (DD)					Minimum Gap
	3-10	3-10	3-10	3-10	3-10	
20	0.0	0.0	0.0	0.0	0.0	The minimum gap is the gap between the closed door and the front of the cabinet.
22	0.0	0.0	0.0	0.0	0.0	
23	0.0	0.0	0.0	0.0	0.0	
24	0.0	0.0	0.0	0.0	0.0	
26	0.0	0.0	0.0	0.0	0.0	
28	0.0	0.0	0.0	0.0	0.0	
30	0.0	0.0	0.0	0.0	0.0	
32	0.0	0.0	0.0	0.0	0.0	
34	0.0	0.0	0.0	0.0	0.0	
36	0.0	0.0	0.0	0.0	0.0	
	Minimum Gap					

**Reveal**

Door Thickness (DT)	Drilling Distance (DD)						Reveal Min. (R)
	3	4	5	6	8	10	
20	0.1	0.1	0.1	0.1	0.1	0.1	
22	0.2	0.2	0.2	0.2	0.2	0.2	
24	0.3	0.3	0.3	0.3	0.3	0.3	
26	0.4	0.4	0.4	0.4	0.4	0.4	
28	0.6	0.6	0.6	0.6	0.6	0.6	
30	0.8	0.8	0.8	0.8	0.8	0.8	
32	2.1	1.1	1.1	1.1	1.1	1.1	
34	4.2	3.1	2.3	1.6	1.4	1.4	
36	6.5	5.2	4.2	3.5	2.2	1.7	
	Reveal Min. (R)						

**Note:** Reveal dimensions were determined with an edge radius (of the door) of 1mm. Hinge dimensions and reveal calculation based on factory setting.

**IMPORTANT**  
To determine the correct application Grass strongly recommends a trial mounting for all hinges and base plates.

**Legend**

- BPH = Base Plate Height
- CC = Center Cup
- DD = Drilling Distance
- DT = Door Thickness
- R = Reveal

**Cup Dimensions**

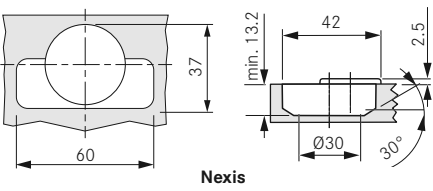

# Nexis 95/+45°

## +45° angle corner cabinet hinge



- 3-dimensional adjustment with suitable base plate
- Soft-close compatible
- Minimal gap dimensions on door thickness of up to 30mm
- For 45° angle corner cabinets
- Self-close hinges available
- Combination drilling pattern for Nexis Impresso

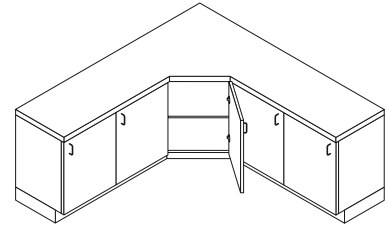

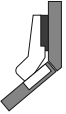
+45° Angle Opening Angle 95°		Impresso				Screw-On		Dowelled		
Inset		Pattern	Type	Item No.	PU	Pattern	Type	Item No.	Item No.	PU
 <p><b>Nexis Impresso:</b> Hinge cup: diecast, nickel-plated Hinge arm: diecast, nickel-plated</p> <p><b>Nexis :</b> Hinge cup: steel, nickel-plated Hinge arm: diecast, nickel-plated</p>	<b>Nexis Impresso:</b>	42/45	Self-close	-		45	Self-close	148.405.06.0315	148.405.08.0315	125
		45/48	Self-close	146.705.35.0315	125	48	Self-close	146.405.53.0315	146.405.54.0315	125

Cover Caps	Cranking 08 and 15	Item No.	PU	Wood Screw, Nickel-plated	Item No.	PU
	Black plastic	514.000.22.9662	1000	 #6 x 5/8" FHP, NI	81001-43	500

PU - Packaging unit



**Corner Angle** **Inset**

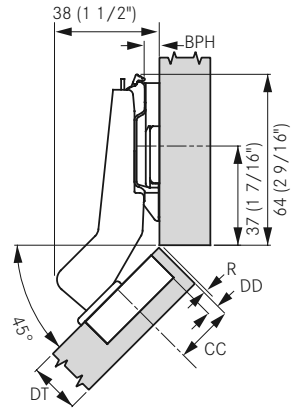

Drawings show Nexis with a base plate, (BPH) 04.

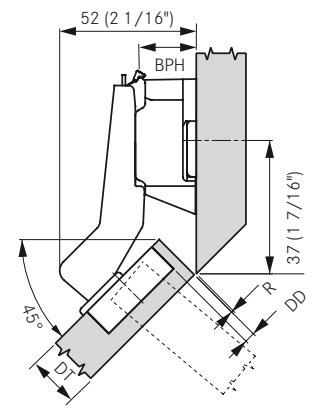

Drawings show Nexis with a base plate, (BPH) 18.

**Drilling Distance (DD)**

*3	4	5	6
	2		4
Base Plate Height (BPH)			

**Minimum Gaps** **Reveal**

**Drilling Distance (DD)**

	3	4	5	6
16	0.5	0.5	0.5	0.5
18	0.5	0.5	0.5	0.5
19	0.5	0.5	0.5	0.5
20	0.5	0.5	0.5	0.5
22	0.5	0.5	0.5	0.5
23	0.5	0.5	0.5	0.5
24	0.5	0.5	0.5	0.5
26	0.5	0.5	0.5	0.7
28	0.5	0.5	0.5	0.9
30	0.5	0.5	1.1	1.1
	Minimum Gap			

The minimum gap is the gap between the closed door and the front of the cabinet.

**Drilling Distance (DD)**

	3	4	5	6
16	0.1	0.1	0.1	0.1
18	0.2	0.2	0.2	0.2
19	0.3	0.3	0.3	0.3
20	0.4	0.4	0.4	0.4
22	0.7	0.7	0.7	0.7
24	1.0	1.0	1.0	1.0
26	1.4	1.4	1.4	1.4
28	1.9	1.9	1.9	1.9
30	3.8	2.9	2.6	2.5
	Reveal Min. (R)			

**Note:** Reveal dimensions were determined with an edge radius (of the door) of 1mm. Hinge dimensions and reveal calculation based on factory setting.

**IMPORTANT** To determine the correct application Grass strongly recommends a trial mounting for all hinges and base plates.

**Legend** **Cup Dimensions**

- BPH = Base Plate Height
- CC = Center Cup
- DD = Drilling Distance
- DT = Door Thickness
- R = Reveal

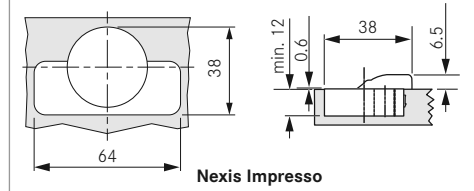
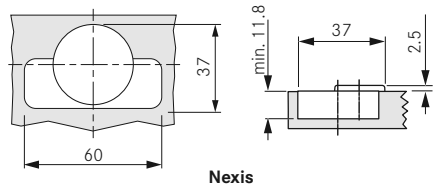

# Nexis 125/-45°

-45° angle corner cabinet hinge, for half overlay doors



- 3-dimensional adjustment with suitable base plate
- For 45° negative angle corner cabinets
- Self-close hinges available

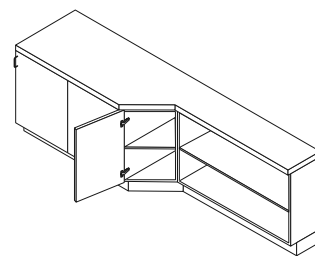

-45° Angle		Opening Angle 125°		Screw-On	Dowelled
------------	--	--------------------	--	----------	----------

Half overlay	Pattern	Type	Item No.	Item No.	PU
 <p><b>Nexis :</b> Hinge cup: steel, nickel-plated; Hinge arm: diecast, nickel-plated</p>	45	Self-close	-	148.429.54.4515	125
	48	Self-close	146.429.53.4515	-	125

Cover Caps	Cranking 08 and 15	Item No.	PU	Wood Screw, Nickel-plated	Item No.	PU
	Black plastic	514.000.22.9662	1000	 #6 x 5/8" FHP, NI	81001-43	500

PU - Packaging unit

### Half Overlay

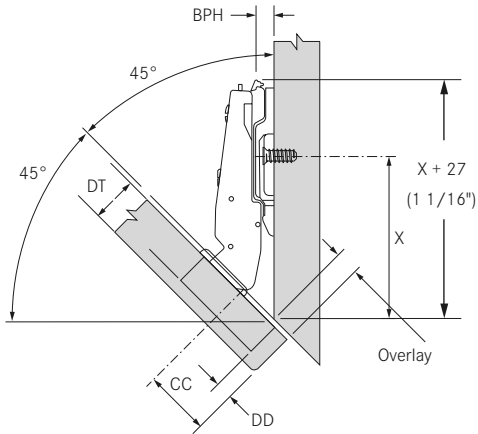

		Drilling Distance (DD)			
		3	4	5	6
Door Overlay	12			0	
	11			0	
	10		0	2	
	9	0		2	
	8		2	4	
	7	2		4	
6		4			
5	4				
		Base Plate Height (BPH)			

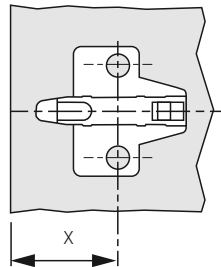

- x = 55.0 with base plate, height 00
- x = 57.0 with base plate, height 02
- x = 59.0 with base plate, height 04

### Minimum Gaps

		Drilling Distance (DD)			
		3	4	5	6
Door Thickness (DT)	16	0.5	1.0	1.8	2.6
	18	1.3	2.1	2.9	3.7
	19	1.9	2.7	3.5	4.3
	20	2.4	3.2	4.0	4.8
		Minimum Gap			

The minimum gap is the gap between the closed door and the front of the cabinet.

### IMPORTANT

To determine the correct application Grass strongly recommends a trial mounting for all hinges and base plates.

### Legend

- BPH = Base Plate Height
- CC = Center Cup
- DD = Drilling Distance
- DT = Door Thickness
- R = Reveal

### Cup Dimensions

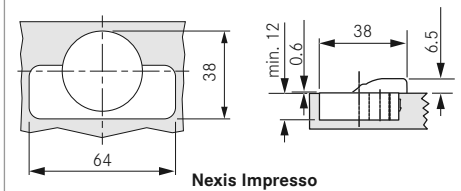
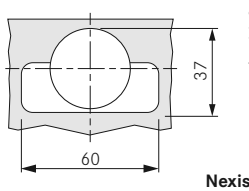

# Nexis 95/90°

## 95° post hinge for blind corner cabinet



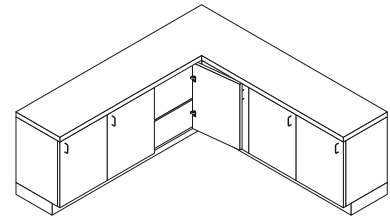

- 3-dimensional adjustment with suitable base plate
- Soft-close compatible
- Minimal gap dimensions on door thickness of up to 30mm
- Self-close hinges available
- For blind corner cabinets



Blind Corner Opening Angle 95°		Screw-On		Dowelled	
--------------------------------	--	----------	--	----------	--

Inset		Pattern	Type	Item No.	Item No.	PU
	Hinge cup: steel, nickel-plated Hinge arm: diecast, nickel-plated	45	Self-close	148.405.11.9615	148.405.12.9615	125
		48	Self-close	-	146.405.54.9615	125

Overlay		Pattern	Type	Item No.	Item No.	PU
	Hinge cup: steel, nickel-plated Hinge arm: diecast, nickel-plated	45	Self-close	148.405.53.1915	148.405.54.1915	125

Cover Caps	Cranking 08 and 15	Item No.	PU	Wood Screw, Nickel-plated	Item No.	PU
	Black plastic	514.000.22.9662	1000	 #6 x 5/8" FHP, NI	81001-43	500

PU - Packaging unit

### Inset

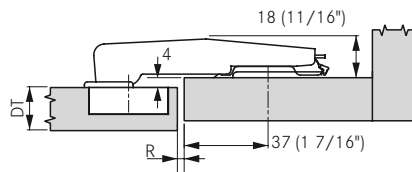

Drawings show Nexis with a base plate, (BPH) 00.

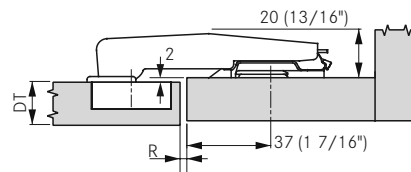

Drawings show Nexis with a base plate, (BPH) 02.

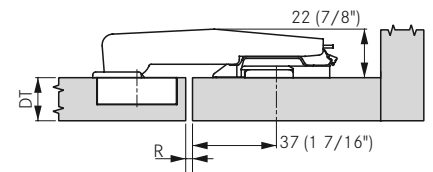

Drawings show Nexis with a base plate, (BPH) 04.

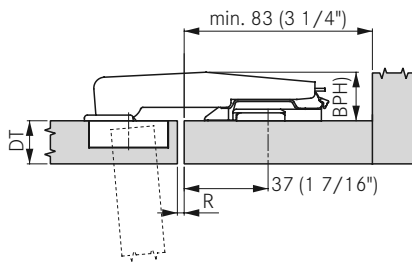

Door Thickness (DT)	Drilling Distance (DD)				Reveal Min. (R)
	*3	4	5	6	
16	0.1	0.1	0.1	0.1	
18	0.2	0.2	0.2	0.2	
19	0.3	0.3	0.3	0.3	
20	0.4	0.4	0.4	0.4	
22	0.7	0.7	0.7	0.7	
24	1.0	1.0	1.0	1.0	
26	1.4	1.4	1.4	1.4	
28	1.9	1.9	1.9	1.9	
30	3.8	2.9	2.6	2.5	

**Note:** Reveal dimensions were determined with an edge radius (of the door) of 1mm. Hinge dimensions and reveal calculation based on factory setting.

#### IMPORTANT

To determine the correct application Grass strongly recommends a trial mounting for all hinges and base plates.

**Note:**  
\*3mm drilling distance for Nexis only  
A door stop is needed to prevent over close.

### Overlay

Drilling Distance (DD)	Door Overlay
3	14
4	15
5	16
6	17

Post Thickness (S)	Base Plate Height (BPH)
19	0
17	2
15	4

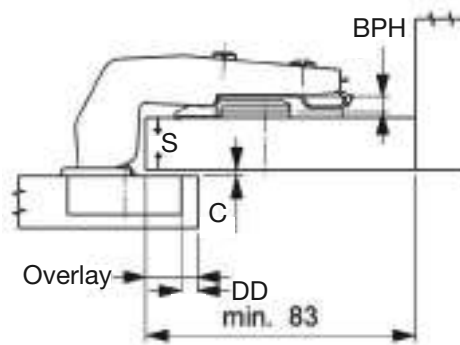

**Note:** Hinge dimensions with factory setting.

### Legend

- BPH = Base Plate Height
- CC = Center Cup
- DD = Drilling Distance
- DT = Door Thickness
- R = Reveal
- S = Post Thickness

### Cup Dimensions

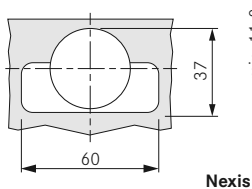

Nexis

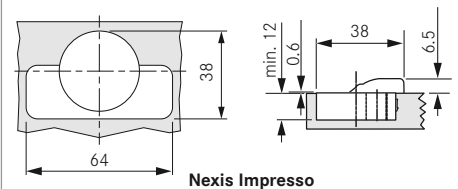

Nexis Impresso

# Nexis PCC

## Pie-cut corner hinge



- 3-dimensional adjustment with suitable base plate
- Designed for connecting two folding doors in corner cabinet
- For door thicknesses 16 to 22mm
- Self-close hinges available
- Used in conjunction with Nexis 170 hinges

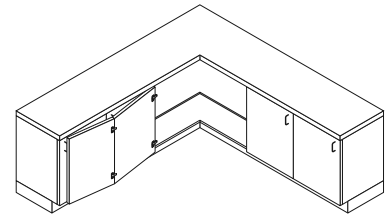

### Pie-cut Corner Hinge

Screw-On

Dowelled

	Pattern	Type	Item No.	Item No.	PU
 <p><b>Nexis :</b> Hinge cup: diecast, nickel-plated; Hinge arm: diecast, nickel-plated</p>	45	Self-close	148.700.01.0015	148.700.02.0015	125
	48	Self-close	146.700.01.0015	146.700.02.0015	125

Cover Caps	Cranking 08 and 15	Item No.	PU	Wood Screw, Nickel-plated	Item No.	PU
	Black plastic	514.000.22.9662	1000	 #6 x 5/8" FHP, NI	81001-43	500

PU - Packaging unit

## Hinge Application

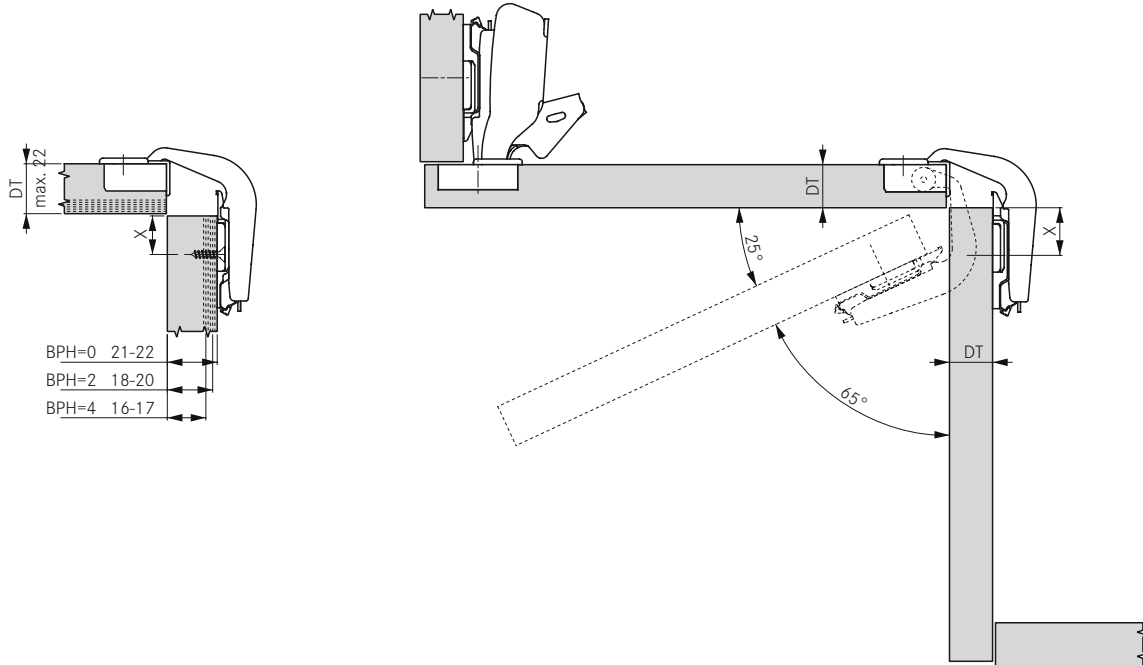

Drawings show Nexis with a base plate, (BPH) 02.

**Note:** Reveal dimensions were determined with an edge radius (of the door) of 1 mm. Hinge dimensions and reveal calculation based on factory setting.

<b>Door thickness (DT)</b>	16	17	18	19	20	21	22
<b>Distance (X)</b>	25	24	22	21	20	18	17
<b>Base Plate Height (BPH)</b>	04		02		00		

### IMPORTANT

To determine the correct application Grass strongly recommends a trial mounting for all hinges and base plates.

### Legend

BPH = Base Plate Height  
 CC = Center Cup  
 DD = Drilling Distance  
 DT = Door Thickness  
 R = Reveal  
 X = Distance

### Cup Dimensions

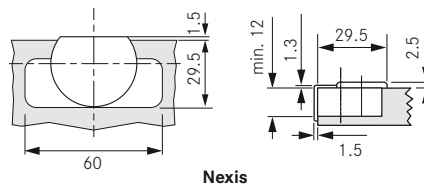

Nexis

# Nexis 21 PCC

## Pie-cut corner hinge with full cup recess



- 3-dimensional adjustment with suitable base plate
- Designed for folding doors in corner cabinets
- For door thicknesses Max. 24mm, factory setting 19mm door thickness with 4mm drilling distance
- Self-close hinges available
- Used in conjunction with Nexis 170 hinges
- Shallow cup depth of 10.8mm

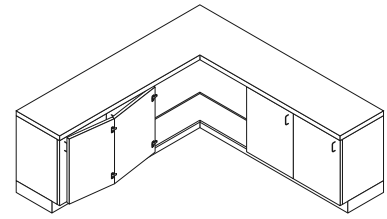

Nexis 21 Piecut Corner Hinge		Screw-On		Dowelled	
Pattern	Type	Item No.	Item No.	PU	
42	Self-close	70139-10	70140-10	125	
42	Self-close	70139-06	70140-06	25	

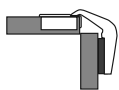

**Nexis :**  
 Hinge cup: steel, nickel-plated;  
 Hinge arm: diecast, nickel-plated

Base Plates for PCC		Cam Base Plate, 2-Point Fixing			
Door Thickness	Screws	Height	Item No.	PU	
18mm-24mm	For wood screws	00	314.493.71.0015	250	
14mm-17mm	For wood screws	02	314.493.71.0215	250	
18mm-24mm	With pre-mounted Euro screws	00	318.493.71.0015	250	
14mm-17mm	With pre-mounted Euro screws	02	318.493.71.0215	250	

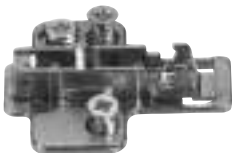
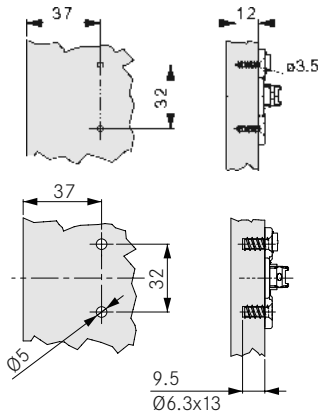
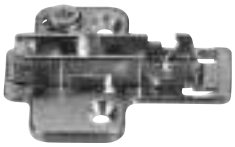

Cover Caps	Cranking 08 and 15	Item No.	PU	Wood Screw, Nickel-plated	Item No.	PU
	Black plastic	514.000.22.9662	1000	#6 x 5/8" FHP, NI	81001-43	500

PU - Packaging unit



## Hinge Application

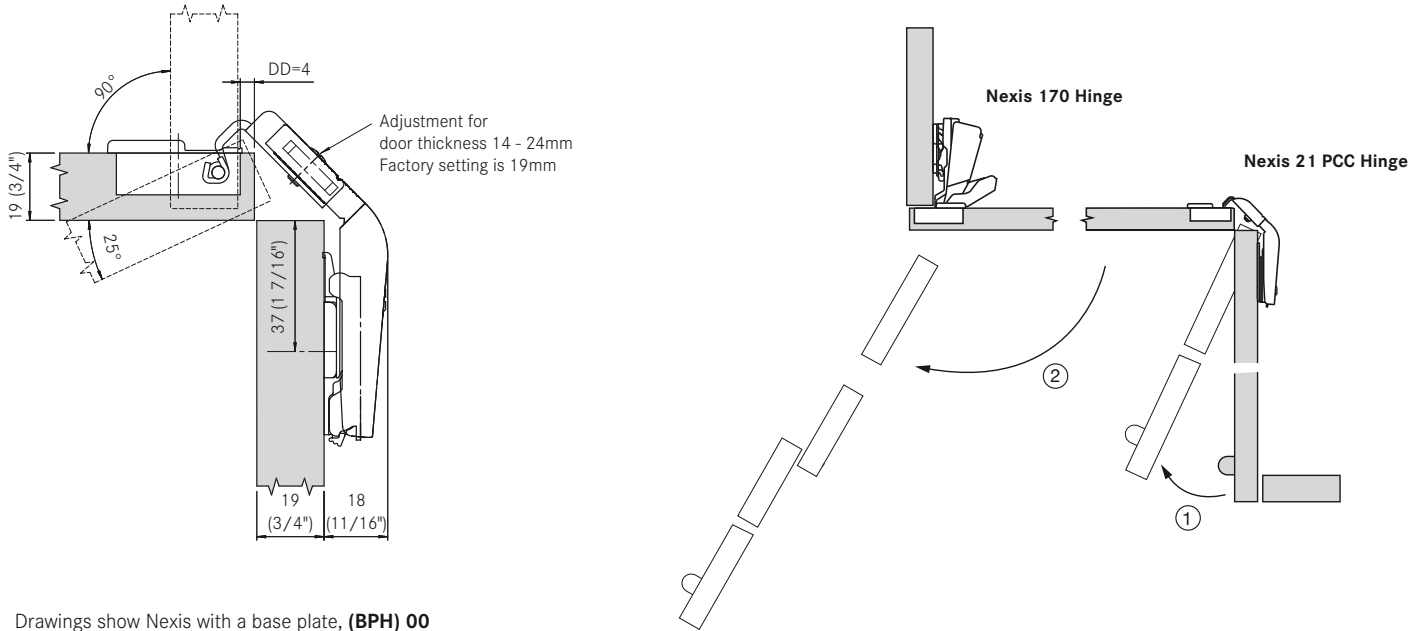

Drawings show Nexis with a base plate, **(BPH) 00**  
for door thickness 19mm, Factory setting.  
Drilling distance range 3mm - 6mm

## Adjustment

### Adjustment in the hinge arm

1. Side adjustment  $\pm 2\text{mm}$
2. Depth adjustment  $\pm 2\text{mm}$
4. door thickness 14 to 24mm,  
factory setting 19mm

### Adjustment via base plate

3. Height adjustment  $\pm 2\text{mm}$

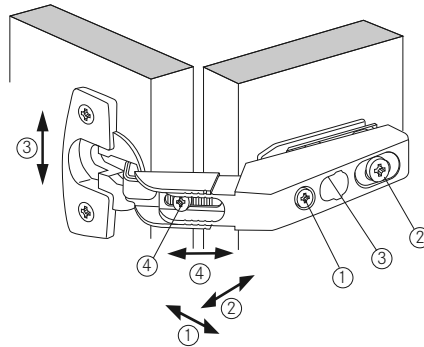

### IMPORTANT

To determine the correct application Grass strongly recommends a trial mounting for all hinges and base plates.

## Legend

BPH = Base Plate Height  
CC = Center Cup  
DD = Drilling Distance  
DT = Door Thickness  
R = Reveal

## Cup Dimensions

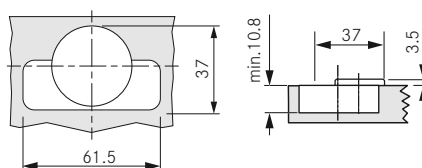

# Nexis 17 GL

## 95° glass door hinge



- 3-dimensional adjustment with suitable base plate
- Glass door hinge, 26mm cup diameter
- For glass thickness 4 to 6mm
- Self-close hinges available

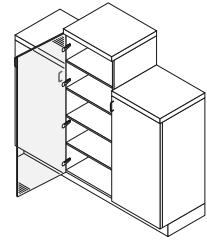

### 17 GL Opening Angle 95°

Overlay	Cranking 00	Pattern	Type	Item No.	PU
	Hinge cup: black plastic; Hinge arm: steel, nickel-plated	48	Self-close	146.017.93.0084	250

**Note: product lead time approximately 8 weeks.**

Half Overlay	Cranking 08	Pattern	Type	Item No.	PU
	Hinge cup: black plastic; Hinge arm: steel, nickel-plated	48	Self-close	146.117.93.0884	250

**Note: product lead time approximately 8 weeks.**

### Decorative Cover Caps

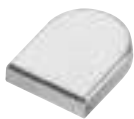



Description	Color	Item No.	PU
Oblong Cover Cap	nickel, velour	359.000.81.1016	25
Oblong Cover Cap	nickel, textured	359.000.81.1019	25
Oblong Cover Cap	brass, textured	359.000.81.1035	25



Description	Color	Item No.	PU
Round Cover Cap	brass, textured	359.000.81.1635	25

**Note: product lead time approximately 8 weeks.**

Cover Caps	Cranking 00 and 08	Item No.	PU	Wood Screw, Nickel-plated	Item No.	PU
	Black plastic	514.000.22.9662	1000	 #6 x 5/8" FHP, NI	81001-43	500

PU - Packaging unit

**Full Overlay**

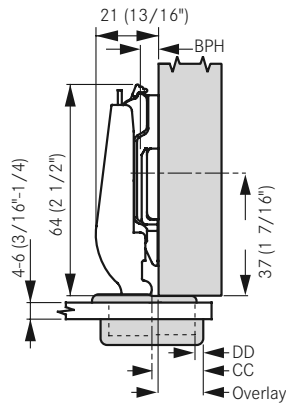

Drawings show Nexis with a base plate, (BPH) 02.

Door Overlay	Drilling Distance (DD)		
	4	5	6
19			0
18		0	
17	0		2
16		2	
15	2		4
14		4	
13	4		
	Base Plate Height (BPH)		

**Half Overlay**

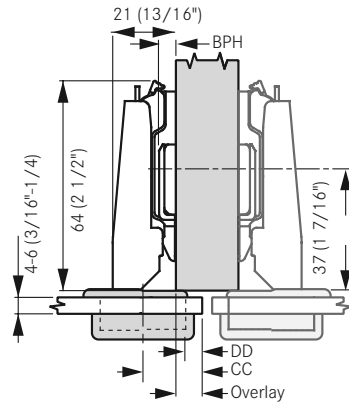

Drawings show Nexis with a base plate, (BPH) 02.

Door Overlay	Drilling Distance (DD)		
	4	5	6
11			0
10		0	
9	0		2
8		2	
7	2		4
6		4	
5	4		
4			
	Base Plate Height (BPH)		

**Assembly**

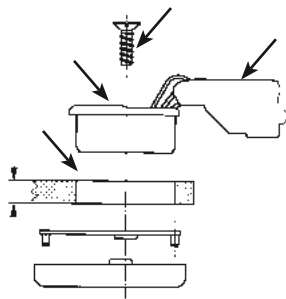

For 1 door order separately:

- 2 Hinges
- 2 Base plates
- 2 Cover plates (oblong/round)

**IMPORTANT**

To determine the correct application Grass strongly recommends a trial mounting for all hinges and base plates.

**Legend**

- BPH = Base Plate Height
- CC = Center Cup
- DD = Drilling Distance
- DT = Door Thickness
- R = Reveal

**Cup Dimensions**

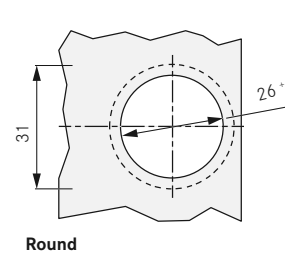
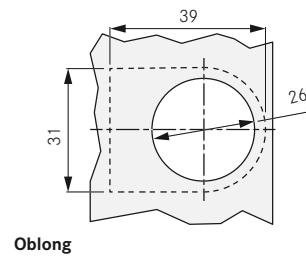
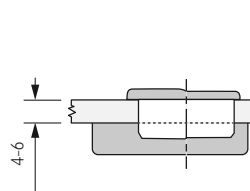

# Base Plates

## Nexis

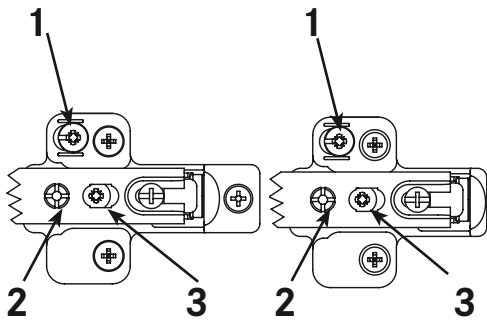

- Steel, nickel plated
- Depth and height adjustment via eccentric cam
- Side adjustment via hinge
- Use a #2 Pozi drive screwdriver for hinge adjustment
- Attach base plates using all available screw holes

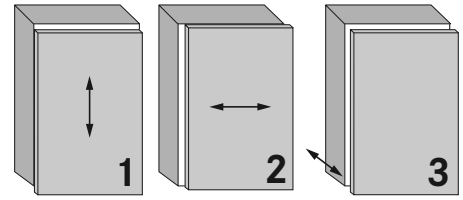

Height adjustment ± 2mm      Side Adjustment +1/-3mm      Depth adjustment +3/-1mm

All adjustment options can be made independently of one another

### Cam Base Plate, 3 Point Fixing For Wood Screw

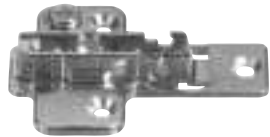

- Height adjustment via eccentric cam

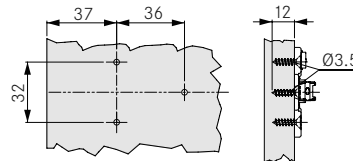

Height	Item No.	PU
00	314.493.70.0015	250
02	314.493.70.0215	250
04	314.493.70.0415	250
08	314.493.70.0815	250

### Cam Base Plate, 3 Point Fixing With Pre-mounted Euro Screws

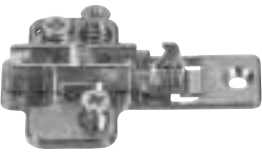

- Height adjustment via eccentric cam

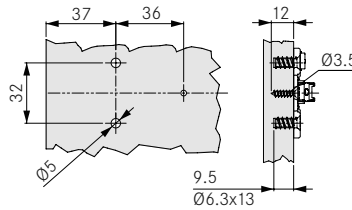

Height	Item No.	PU
00	318.493.70.0015	250
02	318.493.70.0215	250
04	318.493.70.0415	250
08	318.493.70.0815	250

### Cam Base Plate, 2 Point Fixing For Wood Screw

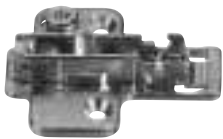

- Height adjustment via eccentric cam

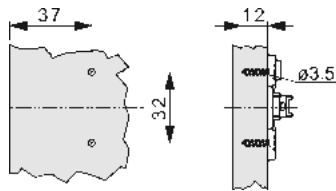

Height	Item No.	PU
00	314.493.71.0015	250
02	314.493.71.0215	250
04	314.493.71.0415	250
08	314.493.71.0815	250

### Cam Base Plate, 2 Point Fixing With Pre-mounted Euro Screws

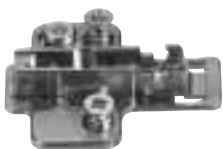

- Height adjustment via eccentric cam

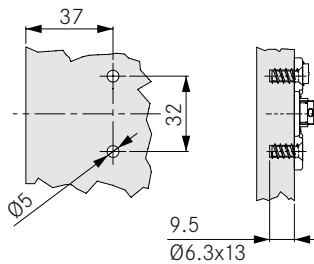

Height	Item No.	PU
00	318.493.71.0015	250
02	318.493.71.0215	250
04	318.493.71.0415	250
06	318.493.71.0615	250
08	318.493.71.0815	250

PU - Packaging unit

# Base Plates

## Nexis

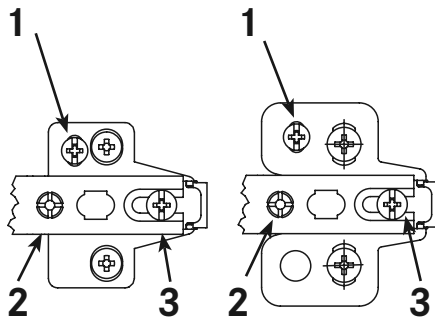

- Height adjustable
- Depth adjustment via hinge arm
- Side adjustment via hinge
- Use a #2 Pozi drive screwdriver for hinge adjustment
- Attach base plates using all available screw holes

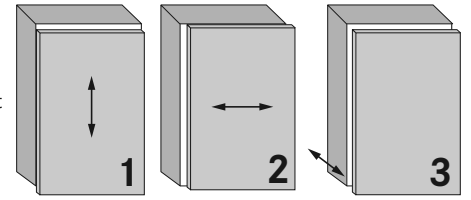

Height adjustment  
± 2mm

Side Adjustment  
+1/-3mm

Depth adjustment  
+3/-1mm

All adjustment options can be made independently of one another

### Cam Height Adjustable Base Plate, 2 Point Fixing

### For Wood Screw



- Height adjustment via eccentric cam
- Steel, nickel-plated

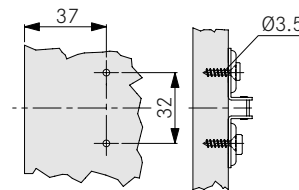

Height	Item No.	PU
00	314.393.69.0015	250
02	314.393.69.0215	250

### Cam Height Adjustable Base Plate, 2 Point Fixing

### For Euro Screws



- Height adjustment via eccentric cam
- Steel, nickel-plated

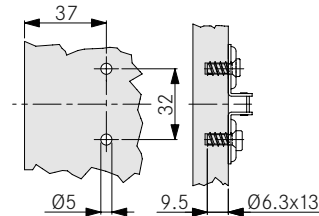

Height	Item No.	PU
00	318.393.69.0015	250
02	318.393.69.0215	250

### 2 Piece Height Adjustable Base Plate, 3 Point Fixing

### For Wood Screw



- Height adjustment via screw
- Steel/die-cast, nickel-plated



Height	Item No.	PU
00	315.393.55.0015	250
02	315.393.55.0215	250
04	315.393.55.0415	250
08	315.393.55.0815	250
18	315.393.55.1815	250

### 2 Piece Height Adjustable Base Plate, 3 Point Fixing

### For Euro Screws



- Height adjustment via screw
- Steel/die-cast, nickel-plated

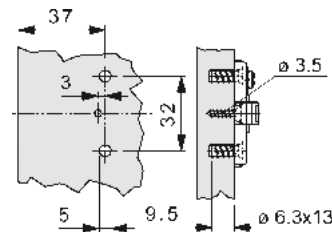

Height	Item No.	PU
00	317.393.56.0015	250
02	317.393.56.0215	250
08	317.393.56.0815	250
18	317.393.56.1815	250

# Base Plates

## Nexis

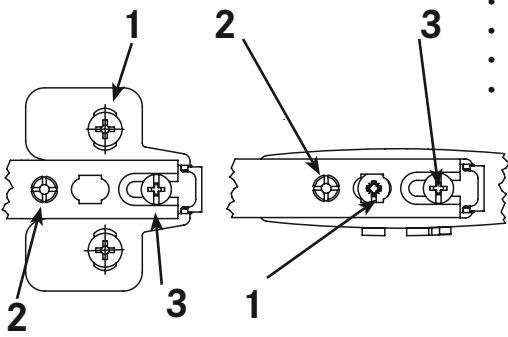

- Steel, nickel plated
- Side adjustment via elongated hole
- Use a #2 Pozi drive screwdriver for hinge adjustment
- Attach base plates using all available screw holes

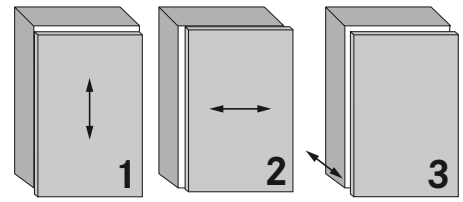

Height adjustment ± 2mm      Side Adjustment +1/-3mm      Depth adjustment +3/-1mm

All adjustment options can be made independently of one another

### Wing Steel Base Plate, 2 Point Fixing For Wood Screw



- Height adjustment via elongated screw holes

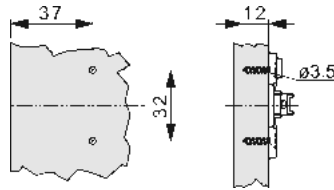

Height	Item No.	PU
00	314.393.81.0015	250
02	314.393.81.0215	250
04	314.393.81.0415	250

### Wing Steel Base Plate, 2 Point Fixing With Pre-mounted Euro Screws



- Height adjustment via elongated screw holes

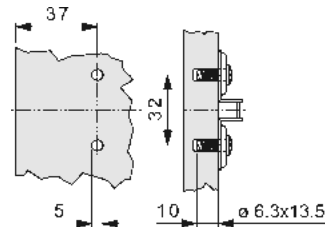

Height	Item No.	PU
00	318.393.81.0015	250
02	318.393.81.0215	250
04	318.393.81.0415	250

### Wing Steel Base Plate, 2 Point Fixing With Pre-mounted Euro Screws



- For common panel application
- Pre-mounted 10.5mm Euro screws
- Height adjustment via elongated screw holes

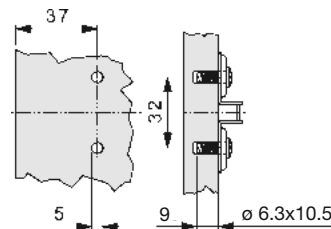

Height	Item No.	PU
00	346.393.92.1015	250

### Linear Base Plate, 2 Point Fixing For Wood Screws



- Height adjustment via cam
- Zinc-diecast

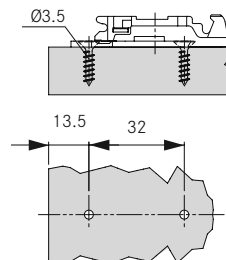

Height	Item No.	PU
00	301.390.91.0015	250

PU - Packaging unit

# Base Plates

## Nexis

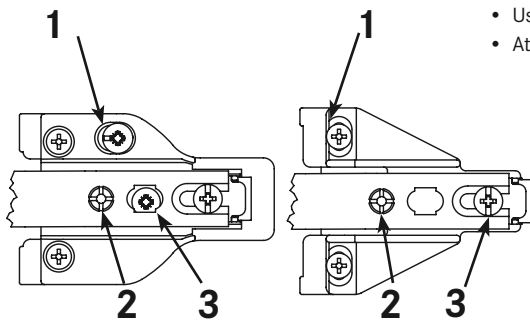

- Use a #2 Pozi drive screwdriver for hinge adjustment
- Attach base plates using all available screw holes

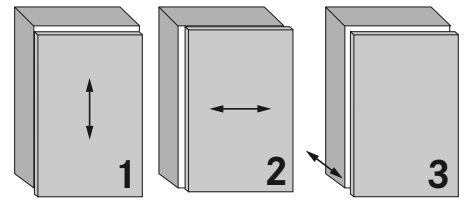



Height adjustment ± 2mm      Side Adjustment +1/-3mm      Depth adjustment +3/-1mm

All adjustment options can be made independently of one another

**FFA Cam Base Plate** **With Pre-mounted Wood Screws**

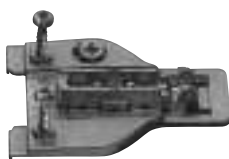
- Height and depth adjustment via eccentric cam

Height	Item No.	PU
00	346.290.92.0015	250
02	346.290.92.0215	250
04	346.290.92.0415	250

**FFA Cam Base Plate** **For Wood Screw**

- Height and depth adjustment via eccentric cam

Height	Item No.	PU
00	346.290.91.0015	250
02	346.290.91.0215	250
04	346.290.91.0415	250

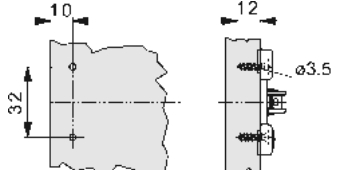
**FFA Base Plate** **For Wood Screw**

- Height adjustment via elongated hole

Height	Item No.	PU
00	346.290.88.0015	250
04	346.290.88.0415	250

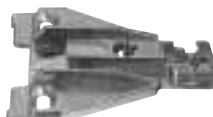
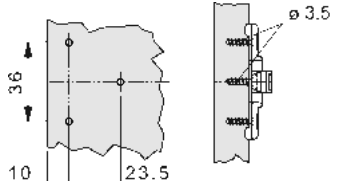
**Inset FFA Base Plate** **For Wood Screw**

- For Inset doors
- To be used with half overlay (cranking 08) hinges
- Height adjustment via screw

Height	Item No.	PU
02	346.290.90.0215	250

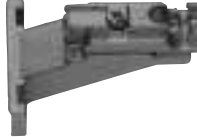
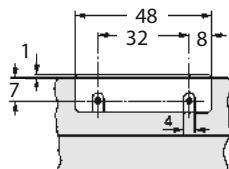
**110° Standard Half Overlay hinge**

Door Overlay	Drilling Distance (DD)		Minimum reveal (R)
	3	4	
22			
21	2.0*		
20	2.0		
19	2.0	1.0*	
18	2.0	1.0	
16	2.0	1.0	

**95° Thick Door Half Overlay Hinge**

Door Overlay	Drilling Distance (DD)		Minimum reveal (R)
	3	4	
24			
22	2.0*		
20	2.0		
19	2.0	1.0*	
18	2.0	1.0	
16	2.0	1.0	

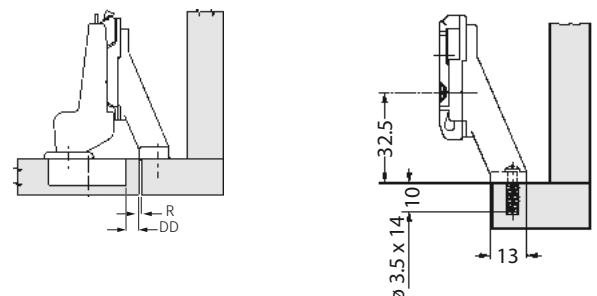

Hinge dimensions and reveal calculation based on factory setting.  
 \*Minimum reveal for doors with beveled edges (R= 1mm) (factory setting).

## NEXIS SOFT-CLOSE

Add a touch of luxury to your cabinet door



**Soft-close, a unique controlled closing device, can be fitted on to the Nexis Impresso and Nexis hinges.**

**The Soft-close adds a cushion that controls and slows the door to a gentle, quiet stop.**



**Soft-close® for Nexis Impresso and Nexis. The unique shock absorber system for cabinet doors.**

The elegant design and state of the art technology of the Nexis Soft-close make the perfect combination for the Nexis Impresso and Nexis hinge series.

Perfect for any application or situation where you want the doors to operate quietly on any type of flat panel door. Adding the Soft-close damper to your doors creates a cushion effect that controls and slows the door closing to a gentle stop. The number of Soft-close dampers per door depends on its size and weight. The Soft-close attaches easily without tools and can be added right from the start or as an addition later on.

**UniSoft, Soft-close adapter**

The UniSoft works for the Nexis Impresso and Nexis full overlay applications on flat panel doors and 5 panel doors. The UniSoft mounts independently from the hinge in the upper corner of your cabinet.

Its brushed nickel look blends well with the hinge finish. The UniSoft can be adjusted by the turn of a screw to the desired closing speed. The UniSoft can be installed at any time during the production process or by the end user after the cabinetry is installed.



# Soft-close 170°

For Nexis Impresso 170° and Nexis 170° wide-angle hinges



- Soft-close adapter for 170° wide-angle hinges
- Slows door action, to close quietly
- Simply snap in place
- Completely tool-free
- Perfect retrofit solution



## Soft-close 170°



Soft-close adapter for Nexis Impresso 170° and Nexis 170° wide-angle hinges with pre-mounted Soft-close damper

Item No.	PU
924.200.46.1115	125

## Installation



## Recommended Position for Soft-close Nexis

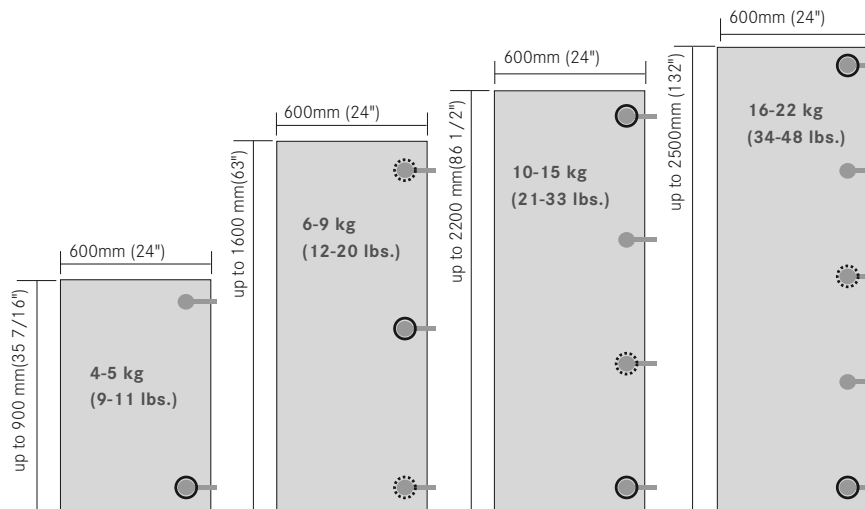

- Recommended position for Soft-close
- ⊙ Position for additional Soft-close (where required)

### IMPORTANT NOTE

The installation of our cabinetry hardware must comply with the Grass instructions that are stated in our available sales brochures; otherwise, Grass cannot be held liable. The company cannot accept any liability in the case of incorrect installation handling. If further information regarding installation and assembly is needed, please contact our factory directly.

# Soft-close Nexis Impresso

For Nexis Impresso 95°, 100°, 110°, and 125° hinges



- Soft-close adapter for Nexis Impresso hinges
- Slows door action, to close quietly
- Quick and easy to attach
- Completely tool-free
- Damping force can be individually adjusted
- Best suited for flat panel doors

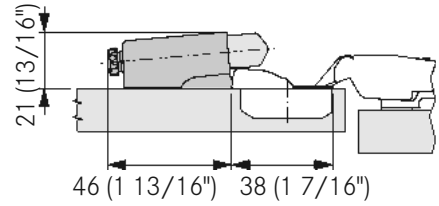

## Soft-close Impresso

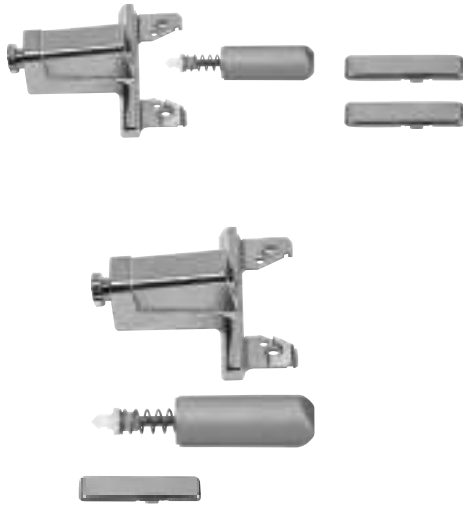

Description	Material	Item No.	PU
Soft-close Impresso Set		924.200.55.0115	125

### 1 set consists of:

- 1 Soft-close adapter for Nexis Impresso hinges
- 1 Soft-close damper
- 2 cover caps

Description	Material	Item No.	PU
Soft-close Impresso adapter		924.200.55.0015	125
Soft-close damper		924.012.50.0142	125
Cover cap for hinges - cranking 00	Steel, nickel-plated	514.300.21.0215	1000

Cover caps Soft-close compatible.

## Installation Instructions for Soft-close Impresso

### Soft-close® Impresso



Check for locator pins to verify Soft-close compatibility.

The installation of our cabinetry hardware must comply with the Grass instructions that are stated in our available sales brochures; otherwise, Grass cannot be held liable. The company cannot accept any liability in the case of incorrect handling. If further information regarding installation and assembly is needed, please contact our factory directly.

**NOTE: For recommended position of Soft-close, please see page 41.**



1. Take door off the cabinet, remove cover cap (if installed) on 00 cranking hinges, open flap of hinge cup.
2. Insert Soft-close Impresso adapter onto locator pins which are attached to the hinge cup.
3. Close Impresso flap of hinge cup completely. 4. Insert Soft-close damper completely into Soft-close adapter with the flattened side pointing down.
4. Mount cabinet door to base plates. Mount cover cap on hinge if desired (cover cap is included in set).
5. Adjust Soft-close Impresso if necessary via adjustment screw.
6. For flat panel doors.

PU - Packaging unit

# Soft-close Nexis

For Nexis 95°, 100°, 110°, and 125° hinges



- Soft-close adapter for Nexis hinges
- Slows door action, to close quietly
- Quick and easy to attach
- Completely tool-free
- Damping force can be individually adjusted
- Perfect retrofit solution

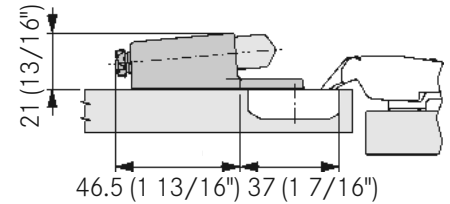

## Soft-close Nexis

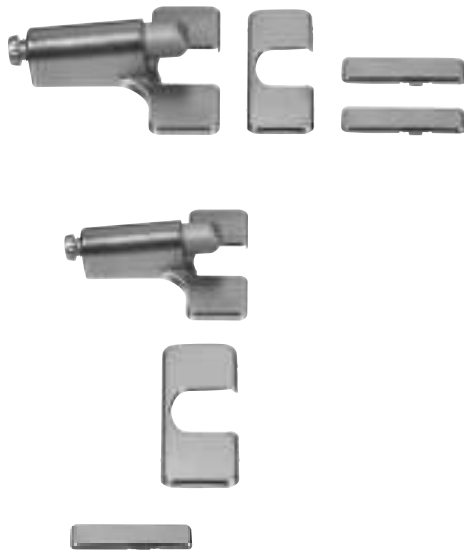

Description	Material	Item No.	PU
Soft-close Nexis Set		924.200.40.0115	125

### 1 set consists of:

- 1 Soft-close adapter with pre-mounted Soft close damper for Nexis hinges
- 1 cover cap for hinge cup
- 2 cover caps for hinge arm

Description	Material	Item No.	PU
Soft-close adapter		924.200.40.0215	125
Cover cap for hinge cup		514.300.20.0115	125
Cover cap for hinges - cranking 00	Steel, nickel-plated, without imprint	514.300.21.0215	1000

Cover caps Soft-close compatible.

## Installation Instructions for Soft-close

### Soft-close® Nexis



Check for notches to verify Soft-close compatibility.

The installation of our cabinetry hardware must comply with the Grass instructions that are stated in our available sales brochures; otherwise, Grass cannot be held liable. The company cannot accept any liability in the case of incorrect handling. If further information regarding installation and assembly is needed, please contact our factory directly.

**NOTE: For recommended position of Soft-close, please see page 41.**

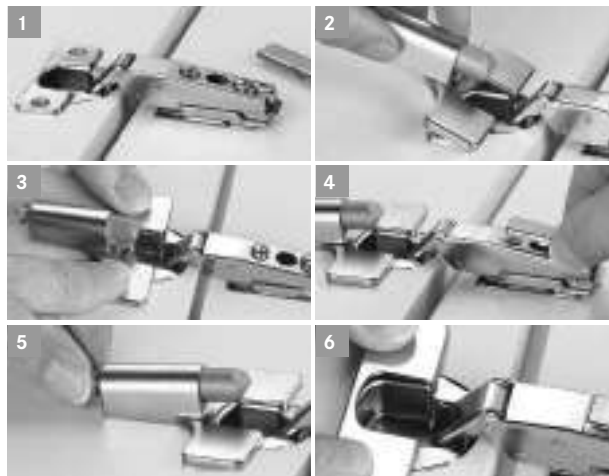

1. Remove cover cap (if installed) on 00 cranking hinges.
2. Insert Soft-close Nexis adapter into notches located on the sides of the hinge cup and attach adapter.
3. Press both sides of the adapter downward until you hear a noticeable "click".
4. Mount cover cap on hinge if desired (cover cap is included in set).
5. Adjust Soft-close Nexis if necessary via adjustment screw.
6. Use cover for hinge cup (included in set) for the hinge without Soft-close Nexis to achieve a uniform appearance.

# UniSoft

## Soft-close for doors



- Works for face frame cabinets on all door overlays
- Works for frameless cabinets on full overlay doors
- Brushed nickel look blends in well with hinge finish
- Non-handed with a low profile design
- Manually adjustable to desired closing speed
- Mounts independently from the hinge in the upper corner of the cabinet
- Instantly allows the cabinet door to close quietly and smoothly
- Scratch protector and front bumper with cushion for a quiet close

### UniSoft Adapter



Description	Material	Item No.	PU
UniSoft, Polybag	Plastic, chrome	18971-37	1
UniSoft, Polybag Bulk	Plastic, chrome	18971-40	25
UniSoft, Bulk	Plastic, chrome	18971-14	250

Includes #6 x 3/4 Pan head screw

### Installation

### Mounting Position

### Adjustment

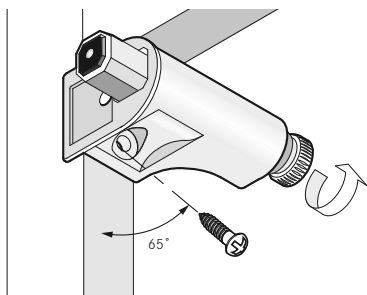

Use a 65° angle for best base results. Pilot drill 2.3mm (Ø3/32") and 1/4" deep for a #6 x 3/4" Pan head screw recommended. Mount in upper corner on hinge side.

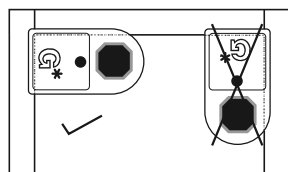

**IMPORTANT** The installation of our cabinetry hardware must comply with the Grass instructions that are stated on this catalog page.

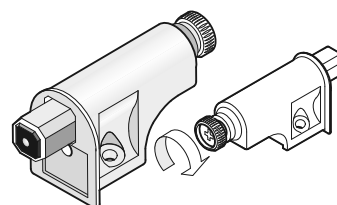

Turn adjustment screw to move damper in and out. Adjust in for heavier doors or out for light doors. Use Phillips or Pozidrive screwdriver or adjust manually.

### Dimensions

### UniSoft per Door

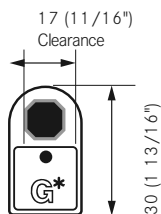
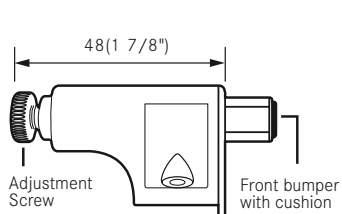

Use one UniSoft for most applications. For heavier doors use two or more. Trial mount recommended.

UniSoft Hinges

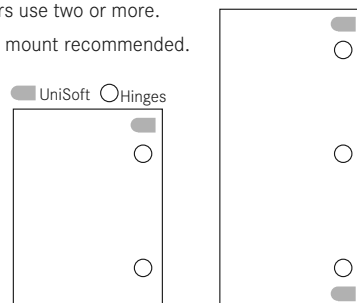

PU - Packaging unit

## TIPMATIC PLUS

A gentle push and the doors seemingly open automatically



**This exclusive solution for handle-free cabinet doors will turn any cabinetry into something special.**

Tipmatic for the Nexis hinge series adds a new element for handle free doors. A gentle tap on the door is enough pressure to open the cabinet door to a convenient angle, making it comfortable and easy to grip the handle free door panel and open it further.

When closing the door, another gentle push activates the magnets and keeps the doors closed. The Tipmatic Plus is the perfect solution when designing cabinetry without handles for a clean, modern design. The Tipmatic Plus is compatible with all Nexis free-swinging hinges and can be used with wood doors and glass doors.



The Tipmatic Plus consists of a Tipmatic adapter, Tipmatic ejector, magnetic pin, and counter plate. The Tipmatic can be installed on the hinge without the use of any tools. The magnetic pin is installed on the interior of the cabinet while the counter plate is glued or screwed onto the cabinet door.

# Tipmatic Plus

For Nexis free swing hinges



- Gently tapping the front causes the doors to open to a convenient angle
- Compatible with all free-swing hinges in the Nexis series
- Perfect retrofit solution

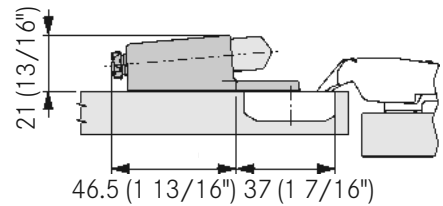

## Tipmatic Plus Set



### 1 set consists of:

- 1 Tipmatic Plus adapter
- 1 Tipmatic Plus ejector
- 1 counterplate for gluing
- 1 counterplate for screw fixing incl. screw
- 1 magnetic pin

Item No.	PU
924.275.40.0315	25

## Face Frame or Standard Adapter Plate



- Quick upgrade installation
- Attach with wood screws (3.5 x 13)
- Plastic RAL 7035, light grey

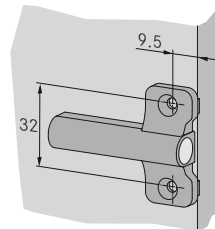

## For Wood Screws

Item No.	PU
63311-40	25

## Linear Adapter Plate



- Design solution - also suitable for inset door applications
- Attach with wood screws (3.5 x 13)
- Plastic RAL 7035, light grey

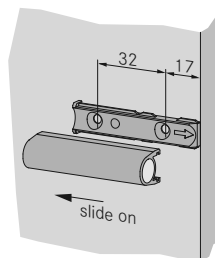

## For Wood Screws

Item No.	PU
63309-40	25

PU - Packaging unit

### Installation Instructions for Tiptmatic Plus

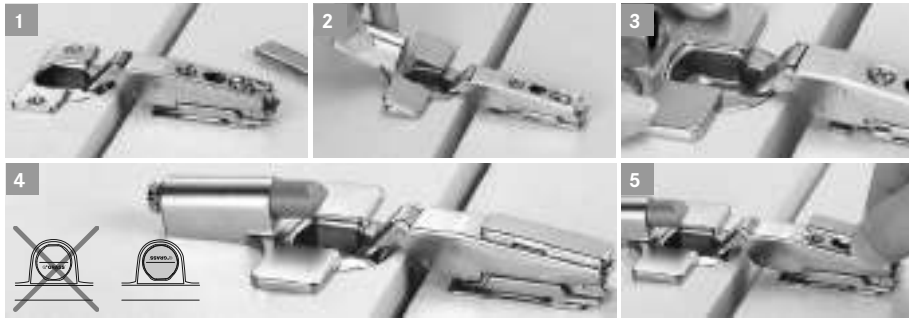

#### Tiptmatic Plus – quick and easy fitting

1. Remove hinge arm cover cap (where applicable).
2. Insert Tiptmatic Plus with the two small hooks underneath into the recesses in the hinge cup, at a slight angle.
3. Push down both sides of the adapter simultaneously until it engages with an audible 'click'.
4. With the flatter side facing downwards, push the Tiptmatic ejector fully into the adapter opening.
5. Adjust front gap, put on hinge arm cover cap (where applicable).

### Installation of Tiptmatic Plus Adapter Plate

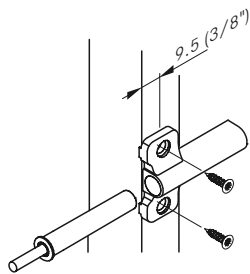

#### Frame adapter Plate

Do not use door bumpers.

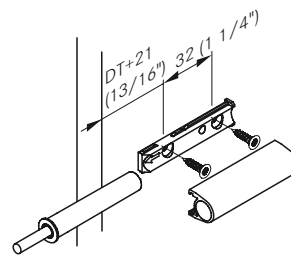
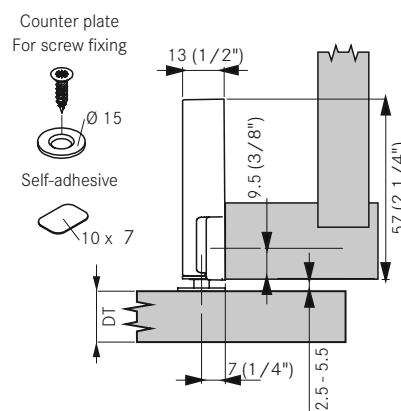

#### Linear adapter Plate

Do not use door bumpers.

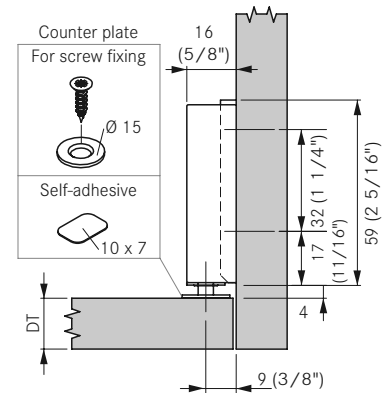

### Recommended Position for Tiptmatic Plus

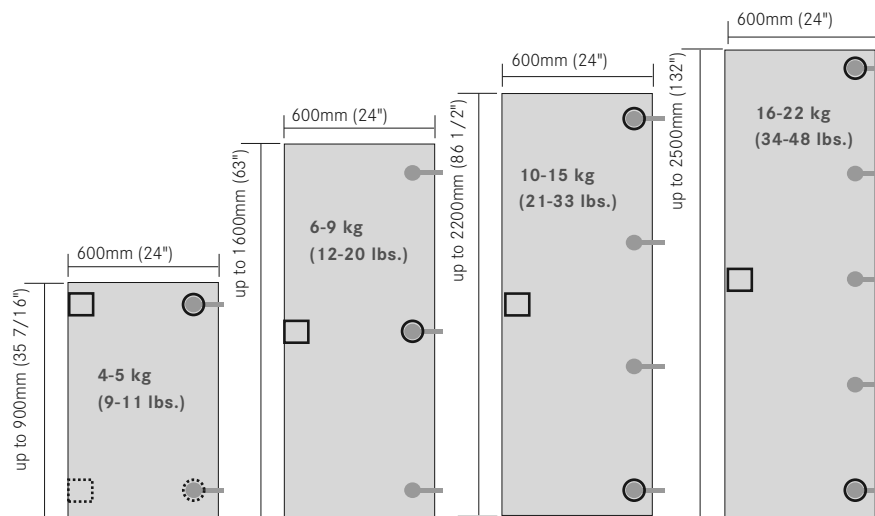

- Recommended position for Tiptmatic Plus .
- Counterplate position (on the same level as the magnetic pin). One magnetic pin per door.
- Recommended position for Tiptmatic Plus for wall cabinet applications.
- Counterplate position for wall cabinet applications (on the same level as the magnetic pin). One magnetic pin per door.

#### IMPORTANT

**Tiptmatic Plus is only suitable for Nexis free-swing hinges. Ensure that the surface is clean and fully degreased before gluing the adhesive plate.**

If Tiptmatic Plus is used in conjunction with a different hold-closed system, Grass does not provide any guarantees.

The installation of our cabinetry hardware must comply with the Grass instructions that are stated in our available sales brochures; otherwise, Grass cannot be held liable. The company cannot accept any liability in the case of incorrect installation or handling. If further information regarding installation and assembly is needed, please contact our factory directly.

# Tipmatic

## For handle-free wooden doors



- Gently tapping the front causes the doors to open to a convenient angle
- Use with Tiomos Tipmatic Plus or with Nexis and Tiomos free-swinging hinges
- Large magnet catch range – holds door closed securely
- Gap adjustment from 2.5 to 5.5mm with integrated, self-locking and tool-free depth adjustment feature
- Mount on the front side of the cabinet or with an adapter plate

### Tipmatic Pin For Drilling



- Incl. Tipmatic mechanism:
  - Stick on strike plate
  - Screw on strike plate
- Hole drilled from the front
- Plastic RAL 7036, platinum grey

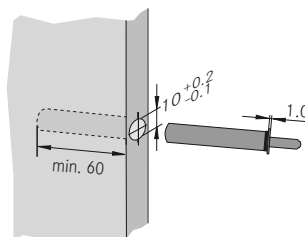

Item No.	PU
68873-06	25

### Adapter Plate for Line Boring For Euro Screws



- Suitable for line boring 28 and 37mm
- Attach with Euro screws (6.3 x 13.5)
- Plastic RAL 7035, light grey

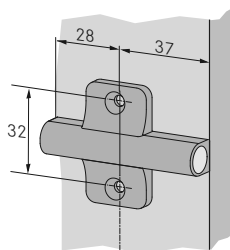

Item No.	PU
63310-40	25

### Face Frame or Standard Adapter Plate For Wood Screws



- Quick upgrade installation
- Attach with wood screws (3.5 x 13)
- Plastic RAL 7035, light grey

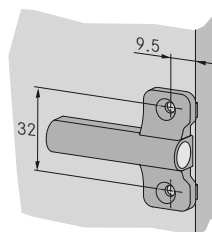

Item No.	PU
63311-40	25

### Linear Adapter Plate For Wood Screws



- Design solution – also suitable for inset door applications
- Attach with wood screws (3.5 x 13)
- Plastic RAL 7035, light grey

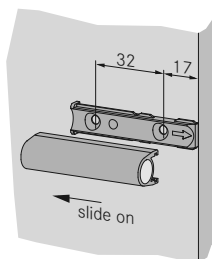

Item No.	PU
63309-40	25

PU - Packaging unit



## Mounting Dimensions

### Tipmatic Pin

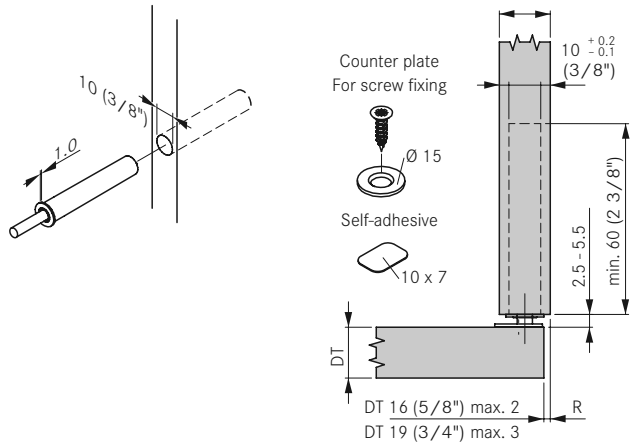

### Adapter Plate for Line Boring

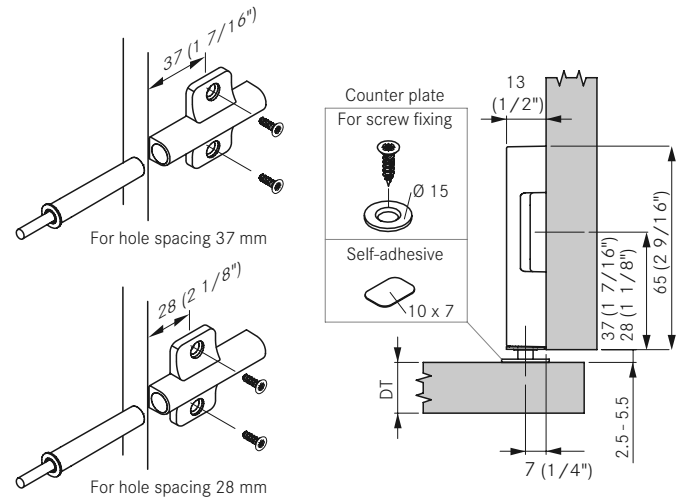

### Linear Adapter Plate, Overlay

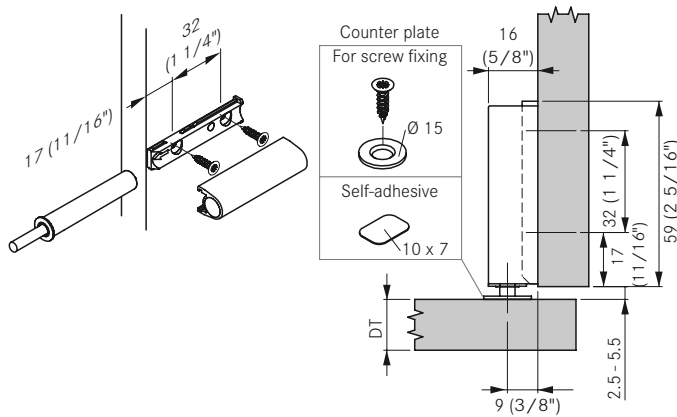

### Linear Adapter Plate, Inset

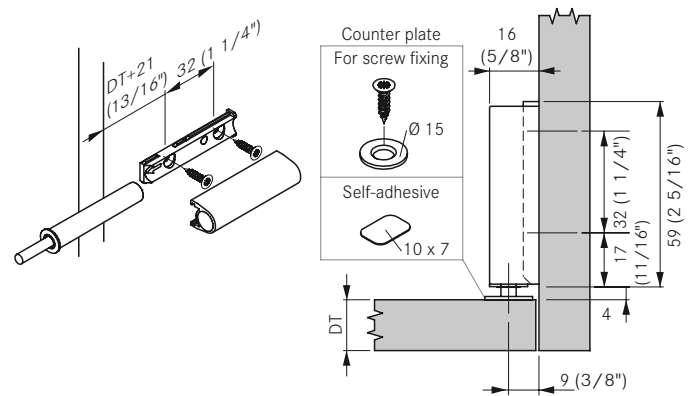

### Face Frame Plate

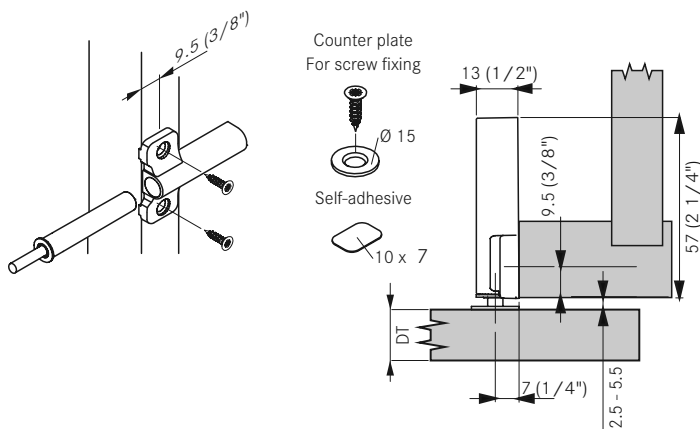

#### Legend

- BPH = Base Plate Height
- CC = Center Cup
- DD = Drilling Distance
- DP = Door Protrusion
- DT = Door Thickness
- G = Gap
- OL = Overlay
- R = Reveal



## INSTITUTIONAL HINGES

### **Designed for high use environments**

Grass Institutional Hinges offer the perfect solution for institutional casework in schools, hospitals, commercial, and furniture environments where the cabinetry has a considerable amount of use. Distinguished by its outstanding durability based on all metal construction, this institutional hinge system is designed for frameless cabinetry and offers high load weight bearing capabilities.



Form. Fit. Function. Engineered to exceed your expectations. Its sturdy design makes it your first choice in institutional cabinetry hardware.

# Institutional Hinge

## Technical Information

### Hinge Insertion



A slight press with the thumb securely connects the door with the cabinet.

### Hinge Removal



Use flathead screwdriver to remove hinge arm from hinge cup with a simple twist.

### Adjustments

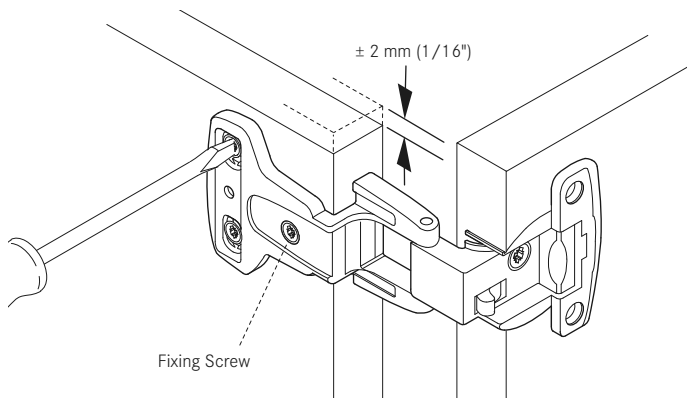

#### Height Adjustment

1. Loosen fixing screw.
2. Adjust door  $\pm 2$ mm up and down.
3. Tighten fixing screw.

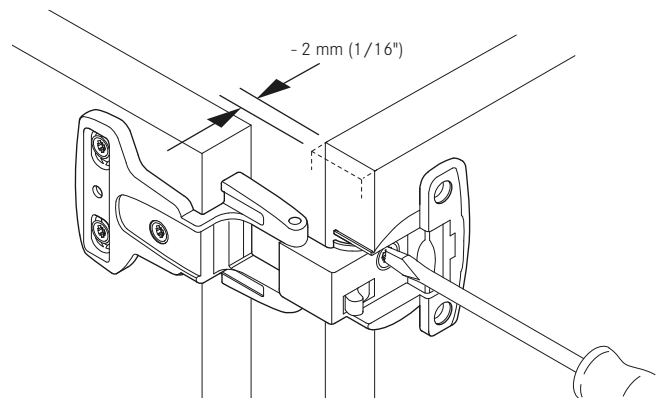

#### Side Adjustment

1. Adjust door 2mm out via Cam adjustment

### Number of Hinges per Door

The number of hinges required depends on the size and weight of the door. The distance between the hinges should be spaced as wide as possible.

Use the diagram to determine the number of hinges needed. These recommendations are for doors without accessory attachments.

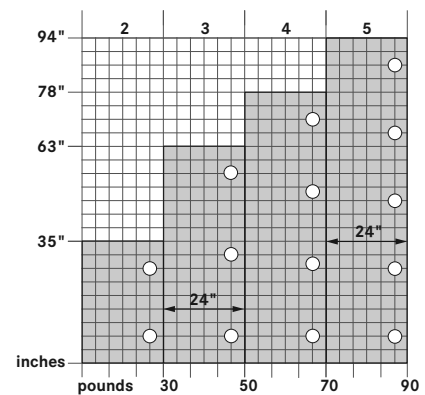

# Institutional Hinges

## MB series barrel hinge



- Hinges made of zinc die-cast construction for extreme durability
- Recommended for side panel thicknesses of 19mm (3/4")
- Tool-free snap-on mounting - quick and easy installation
- All types of hinge mounting (corner and center wall)
- Side-to-side adjustment of - 2mm (1/16")
- Height adjustment of +/- 2mm (1/16")
- Cover cap conceals mounting screws
- Available in black and nickel plated
- Designed for frameless cabinet construction
- Opening angles range from 180° to 270°
- \*Meets ANSI/BHMA A156.9 - Grade I requirements

### How to specify institutional hinge hardware:

1. Choose screw-on or dowelled cup: one cup fits all hinge arms.
2. Choose hinge arm based on application (cover cap included).
3. Special #6.3 x 13.5mm Euro screws (2) required for hinge arm mounting. Must be ordered separately.



MB 8010 Hinge Cup		Screw-On		Dowelled	
Hinge Cup	Pattern	Material	Item No.	Item No.	PU
 MB 8010 Hinge Cup - 45mm pattern	45	Nickel Plated	<b>F150000006233</b>	<b>F150000021233</b>	200
	45	Black	<b>F150145123233</b>	<b>F150145124233</b>	200

### Hinge Arms

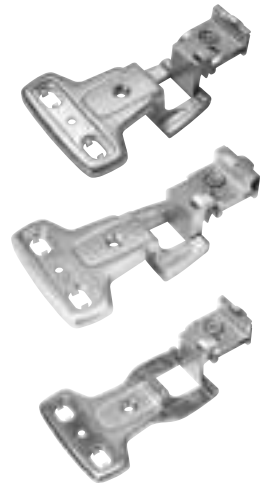

Description	Material	Item No.	PU
MB 8310 Hinge Arm - Full Overlay -15mm (19/32")	Nickel Plated	<b>F150000014223</b>	100
	Black	<b>F150145125223</b>	100

Description	Material	Item No.	PU
MB 8510 Hinge Arm - Half Overlay - 5.5mm (7/32")	Nickel Plated	<b>F150000015223</b>	100
	Black	<b>F150145399223</b>	100

Description	Material	Item No.	PU
MB 6110 Hinge Arm - Inset	Nickel Plated	<b>F150000007223</b>	100

### Common Panel Hinge Arm



Description	Material	Item No.	PU
MB 8610 Common Panel Hinge Arm - 5.5mm (7/32")	Nickel Plated	<b>F150000016223</b>	100
	Black	<b>F150145394223</b>	100

Euro Screws for Hinge Arm Mounting	Item No.	PU
6.3 x 13.5mm Nickel Plated	B405.000.51.25	100

### Cover Cap



Cover cap included with hinge arm

\*Meets Grade I requirements when third screw and adjustment tabs are in place.

PU - Packaging unit

**Full Overlay 270°**      **Half Overlay 230°**

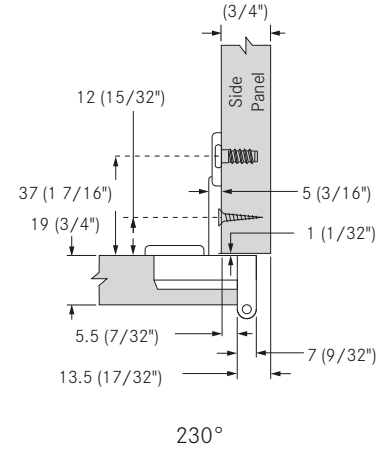
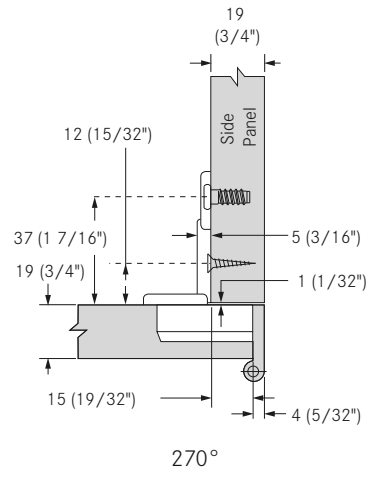

**Common Panel 180°**      **Inset 180°**

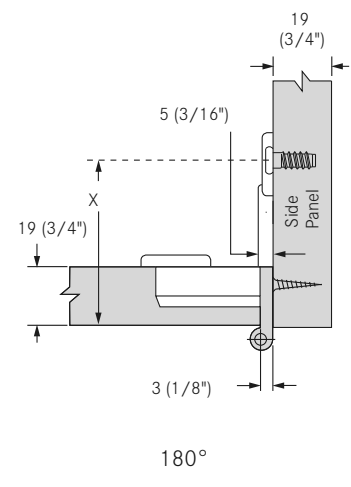
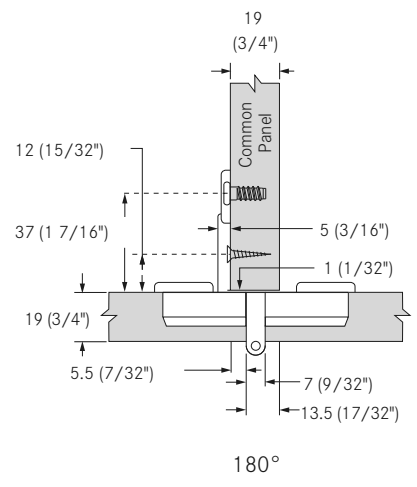

**Hinge Arm Dimensions**      **Specifications**

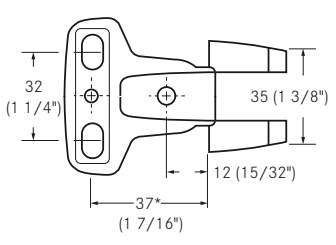

**Institutional hinges**  
**32mm compatible**  
 \*For Inset doors use:  
 39mm (1 17/32") + Door Thickness

	Reveal	Opening Angle	Overlay
<b>Application</b>			
Full Overlay	4mm (5/32")	270°	15mm (19/32")
Half Overlay	13.5mm (17/32")	230°	5.5mm (7/32")
Common Panel	7mm (9/32")	180°	5.5mm (7/32")
Inset	3mm (1/8")	180°	-

**Cup Depth**      **Hinge Cup**      **Cup Drilling**

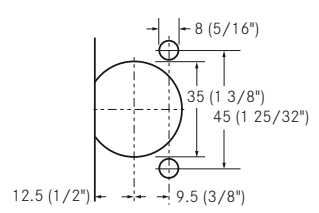
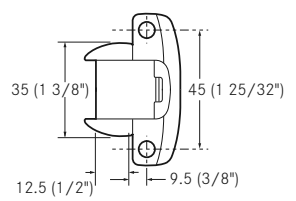
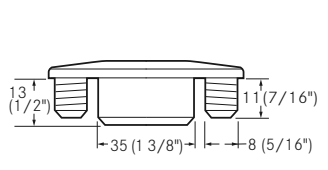

**IMPORTANT**  
 To determine the correct application Grass strongly recommends a trial mounting for all hinges and base plates.

# Nexis Slide-on 73

## 270° single-joint Institutional hinge



- 3-dimensional adjustment with suitable base plate
- For door thicknesses 15 to 21mm
- For door overlay up to 16mm (5/8")
- Automatic hold-closed function
- Meets ANSI/BHMA A156.9 - Grade II requirements

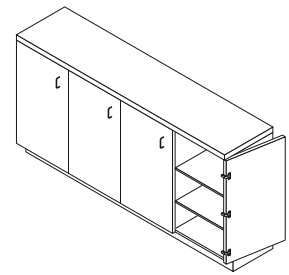

Nexis 73	Opening Angle 270°	Screw-On	Dowelled
----------	--------------------	----------	----------

Full Overlay	Cranking 00	Pattern	Type	Item No.	Item No.	PU
	Hinge cup: diecast, nickel-plated; Hinge arm: diecast, nickel-plated	48	Hold-close	412.770.08.0015	417.770.09.0015	125

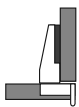

### Base Plates, 2 and 3-Point Fixing

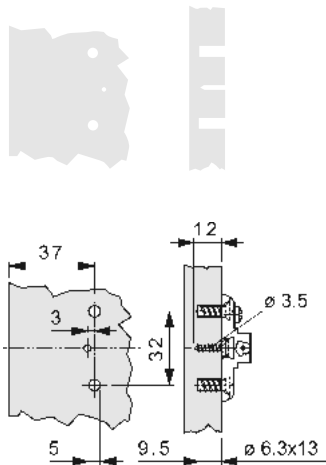
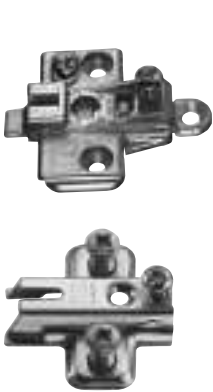

Height	Description	Item No.	PU
00	Zinc die-cast, nickel plated for Euro Screw	317.293.66.0015	250

Height	Description	Item No.	PU
00	Steel, nickel plated with pre-attached Euro Screws	318.393.52.0015	250

Cover Caps	Cranking 08 and 15	Item No.	PU	Wood Screw, Nickel-plated	Item No.	PU
	Black plastic	514.000.22.9662	1000	#6 x 5/8" FHP, NI	81001-43	500

PU - Packaging unit

### Full Overlay

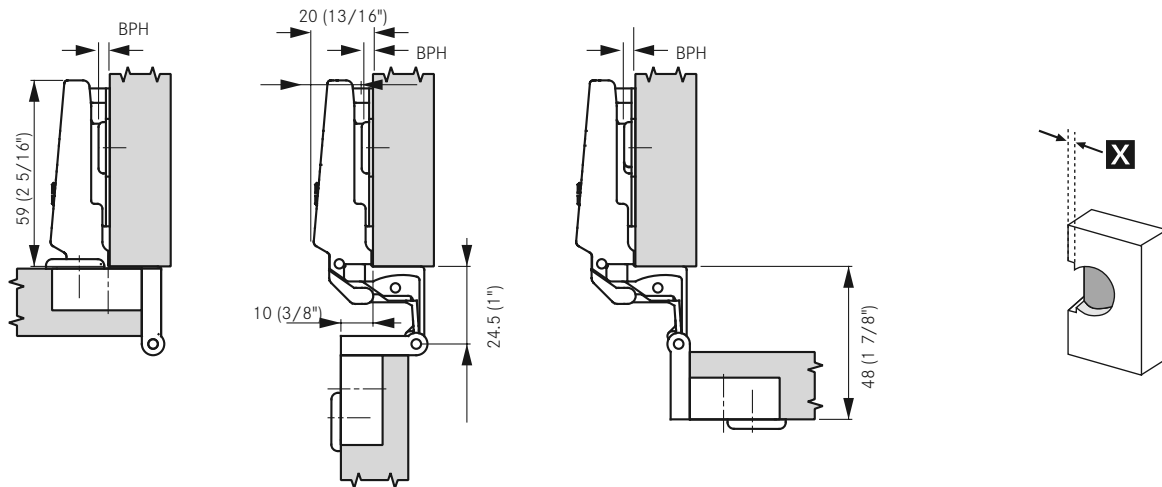

Drawings show hinge with a base plate, (BPH) 00.

### Door Overlay

		Depth of cut-out (x)						
		6	5	4	3	2	1	0
Door Overlay max.	16	0						
	15		0					
	14	2		0				
	13		2		0			
	12	4		2		0		
	11		4		2		0	
	10			4		2		0
	9				4		2	
	8					4		2
	7						4	
6							4	
		Base Plate Height (BPH)						

**Note:** Hinge dimensions and gap calculation based on factory setting.

#### IMPORTANT

To determine the correct application Grass strongly recommends a trial mounting for all hinges and base plates.

### Drilling Patterns

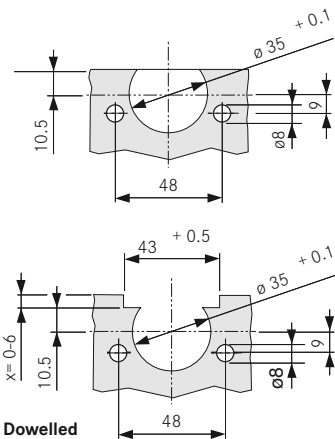
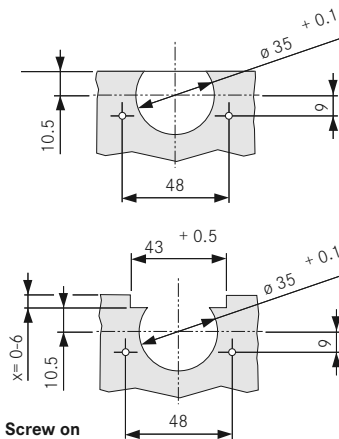

### Cup Dimensions

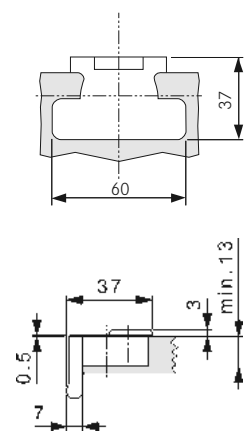

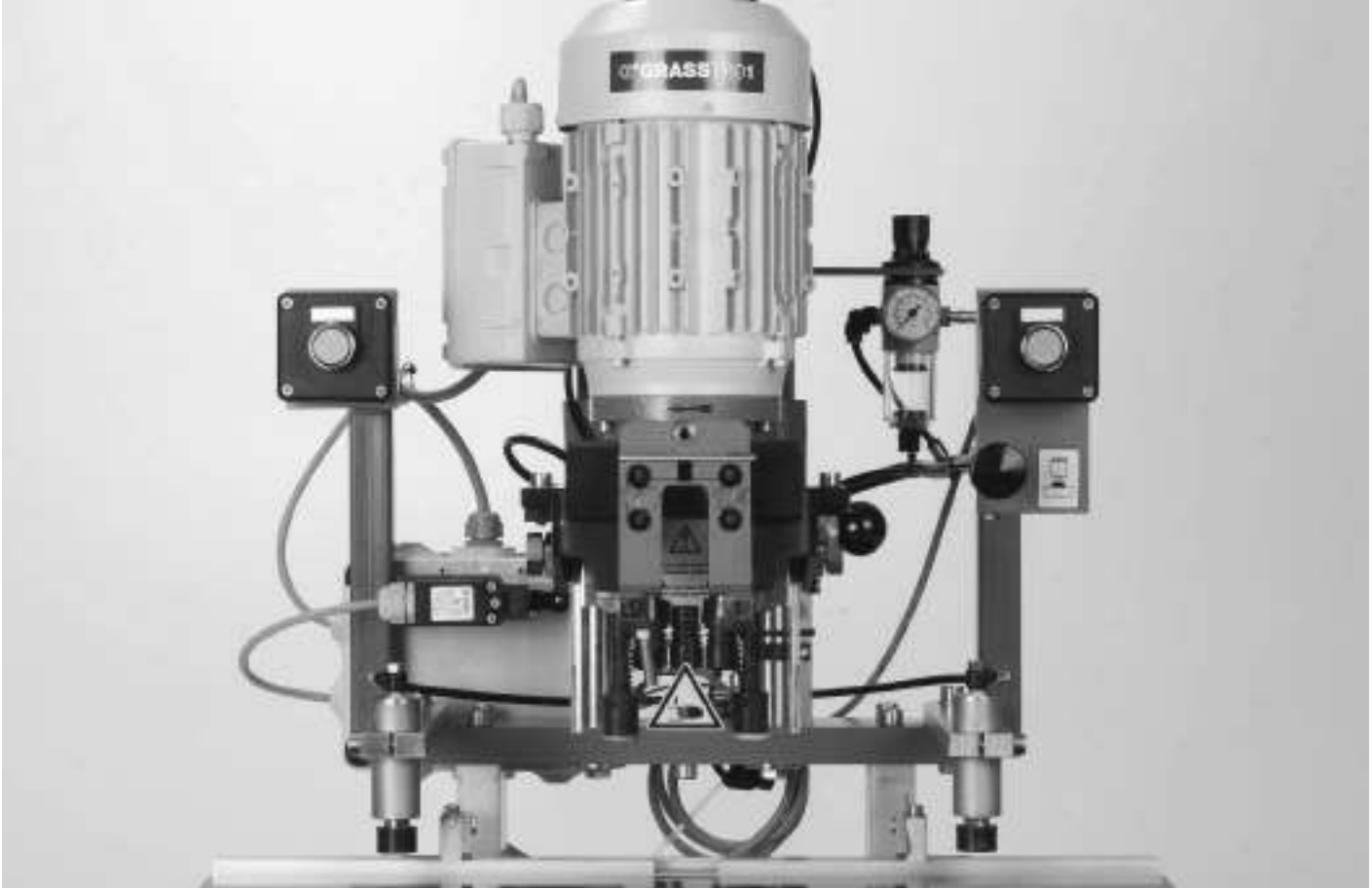

## SPECIALTY HINGE ITEMS

**Grass offers a wide variety of specialty hinge items to meet every application imaginable.**

Whether you need a Pie Cut Corner hinge for a lazy susan application, a no-bore glass door hinge for a china cabinet or a steel door hinge for a medicine cabinet, Grass can provide a unique solution for your specific hardware application.

Balancing convenience, function and reliability to make installation easier while reducing your labor cost is our goal. Grass also offers machinery for hinge door drilling and insertion. Choose from a selection of machinery that will fit your needs.

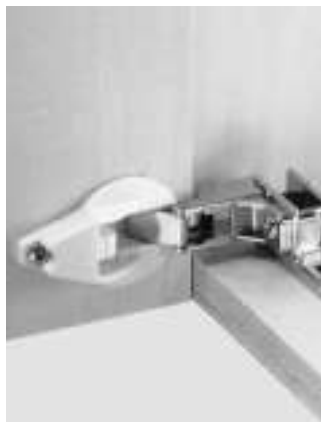



# Tri-view-mirror hinge

90° hinge for wooden or steel doors



- For medicine cabinets with wooden or steel doors
- Concealed self-locking hinge, top and bottom mount, for mirror cabinets and variable angle cabinets without partition
- Universal left and right handed

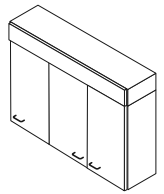

## Tri-view-Mirror Opening Angle 90°



Description	Material	Item No.	PU
Hinge for wood doors	Hinge cup: white plastic Hinge arm: diecast, nickel-plated	212.100.34.9570	250

Description	Material	Item No.	PU
Hinge for metal doors	Hinge cup: white plastic Hinge arm: diecast, nickel-plated	212.100.36.9570	250

Note: Base plate must be ordered separately.

## Suitable Base Plate



Material	Item No.	PU
diecast, nickel-plated	511.200.04.9515	250

## Center Plate (optional)



Material	Item No.	PU
nylon	514.000.51.0061	250

Nylon center plate allows adjustment and correct positioning of screws.

## Mounting Measurements for Wood Doors

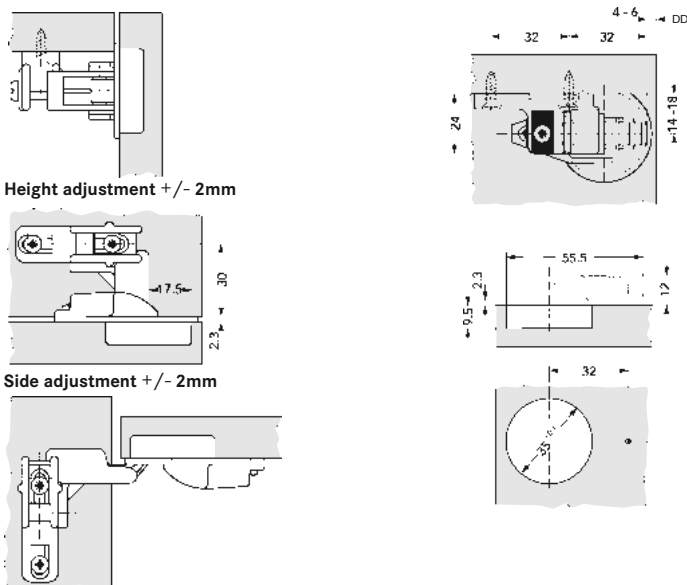

## Mounting Measurements for Metal Doors

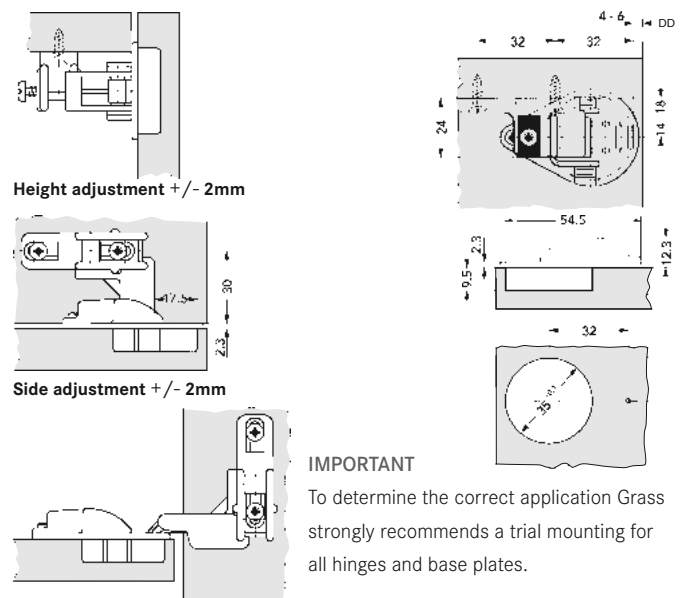

### IMPORTANT

To determine the correct application Grass strongly recommends a trial mounting for all hinges and base plates.

# 975 VZ PCC

## Pie Cut Corner Hinge



- Small or large gap between door
- Shallow profile does not interfere with lazy susans
- Same drilling on both doors
- Height adjustable
- Accommodates doors 15 to 24mm thick.

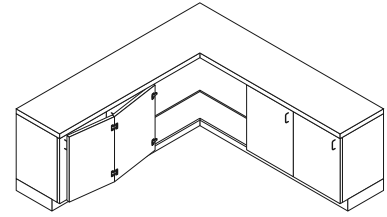

### 975 VZ Pie Cut Corner Hinge

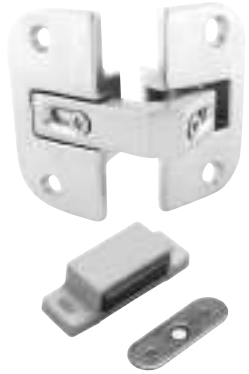

Description	Material	Item No.	PU
975 VZ Pie Cut Corner Hinge kit	Hinge: Zinc, nickel-plated	13128-37	1
975 VZ Pie Cut Corner Hinge	Hinge: Zinc, nickel-plated	13127-09	100

**1 kit consists of:**

- 2 PCC hinges (13127-01)
- 1 strike plate
- 1 magnetic catch
- 1 instruction sheet

### Door Sizing Example

Door Sizing Example	
Overall cabinet opening	305mm
-Reveal	3mm
	=302mm
-2mm gap for bumper pad	2mm
	=300mm
- Door Thickness	19mm
	=281mm
-1mm Gap between doors	1mm
<b>Door Size</b>	<b>= 280mm</b>

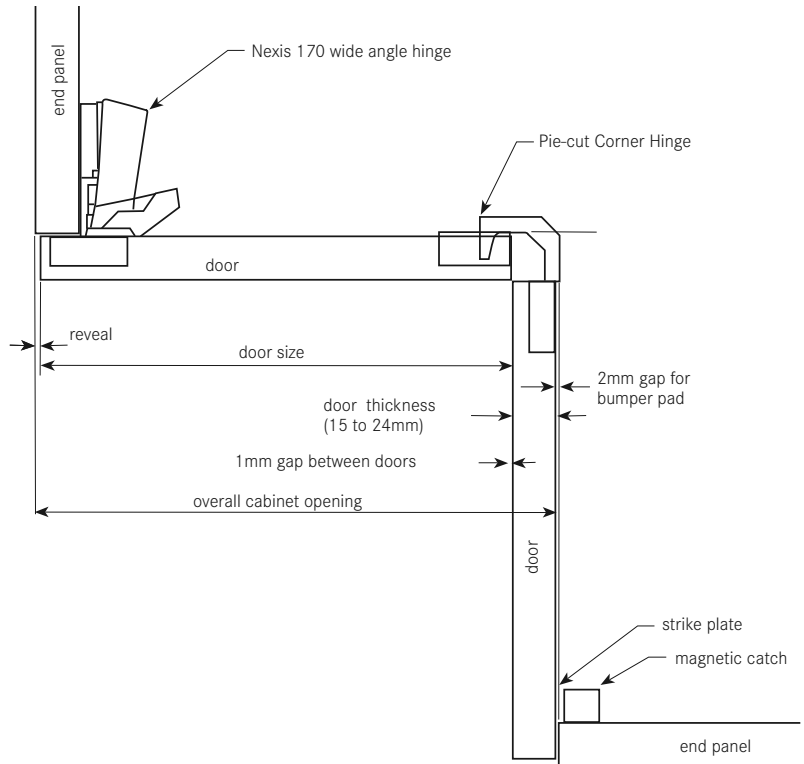

**Note:**

Use a POZIdrive screwdriver for hinge adjustment.  
 Fastening screws for hinge: #6 x 5/8" FHP (not included)  
 Fastening screws for catch: #4 x 5/8" FHP (not included)

**IMPORTANT**

To determine the correct application Grass strongly recommends a trial mounting for all hinges and base plates.

PU - Packaging unit

5/8" Door Thickness Application

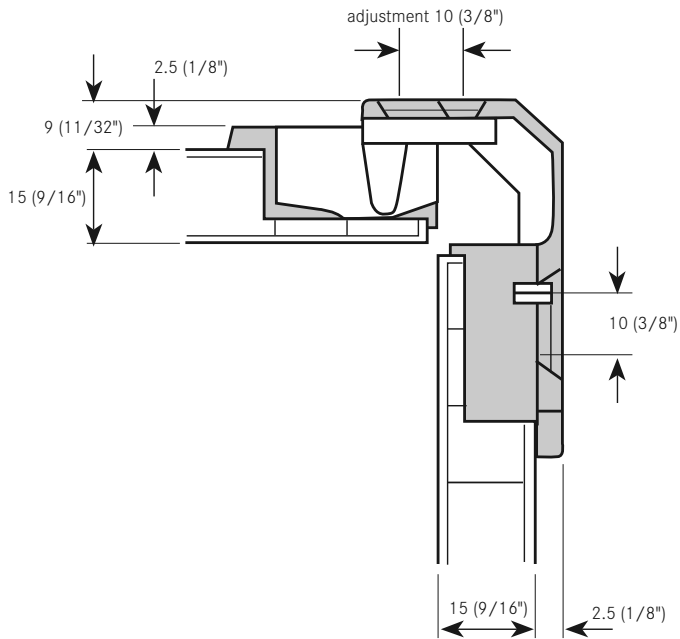

1" Door Thickness Application

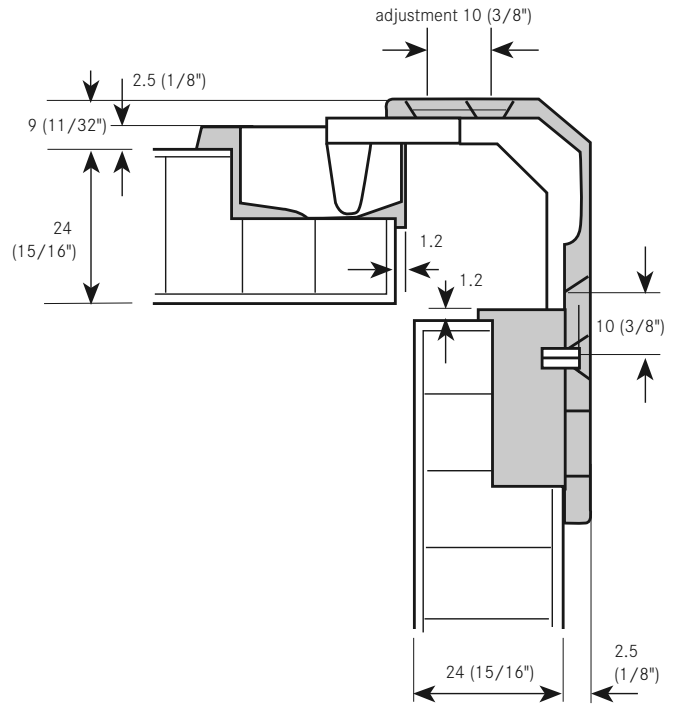

Adjustment

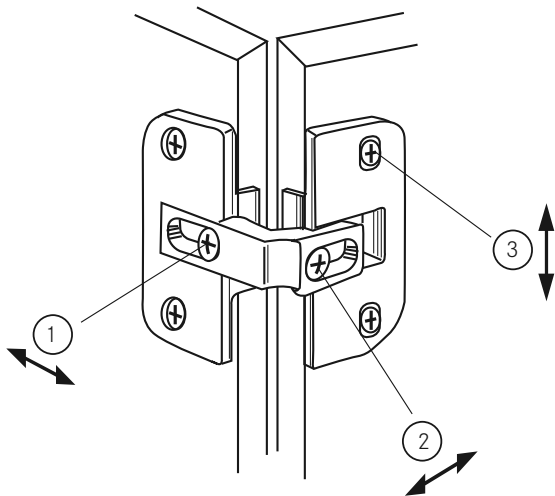

- 1. Side Adjustment up to 10mm
- 2. Depth Adjustment up to 10mm
- 3. Height Adjustment ± 1mm

Cup Dimensions

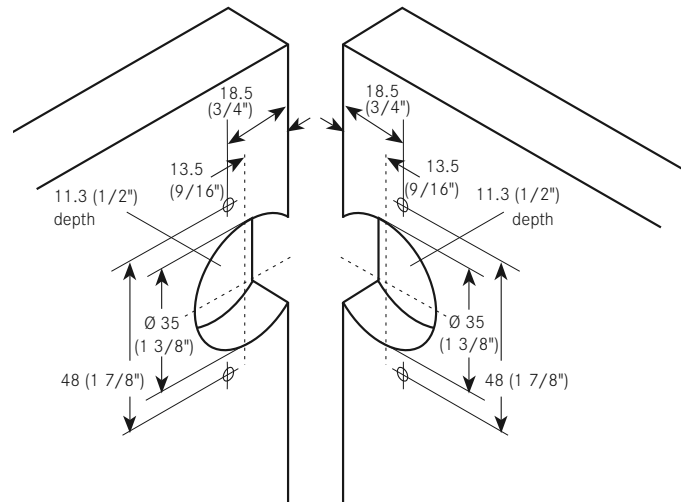

# Flap hinge

90° flap with 35mm cup



- For flap thicknesses up to 20mm
- Cup edge cover
- Bottom and flap door are flush inside the cabinet when doors are open
- Hinge is supplied unassembled
- Identical drilling pattern for base and flap door
- 3-dimensional adjustment
- Sturdy design

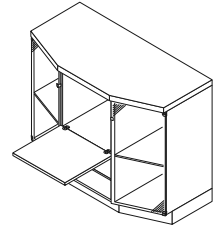

## Flap Hinge Opening Angle 90°

Full Overlay	Item No.	PU
	210.735.04.0015	100



Hinge cup: diecast, nickel-plated;  
Hinge arm: diecast, nickel-plated

## Mounting Measurements for Flap Hinge Hinges per Door

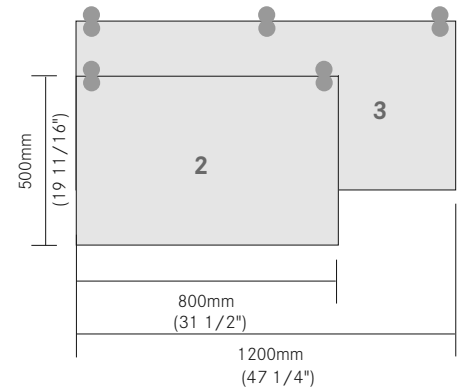
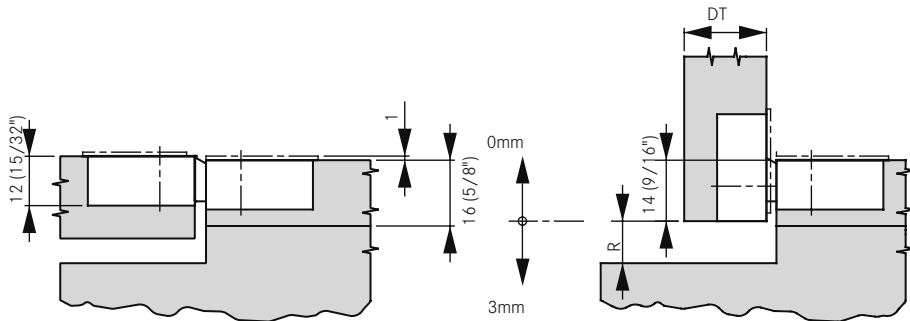

Fixing of flap and base parts using chip board screws  $\varnothing 3 \times 13$  m (screws not included).

Hinge dimensions and calculation of gap based on factory setting.

Flap thickness (DT)	14	15	16	17	18	19	20
Gap min. (R)	0.2	1.0	2.0	3.0	3.8	5.0	6.0

### IMPORTANT

To determine the correct application Grass strongly recommends a trial mounting for all hinges and base plates.

## Cup Dimensions Adjustment

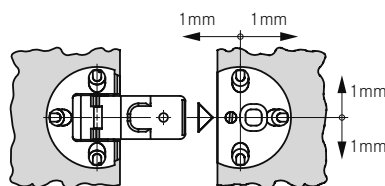
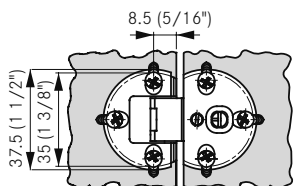

PU - Packaging unit

# Glass door hinge

## 180° No-bore glass door hinge



- Opening angle 180°
- Direct mounting on cabinet sidewall
- Inset application
- Includes self-adhesive pads
- Thickness of glass: 4-6mm

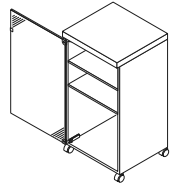

### No-bore Hinge



Description	Location	Material	Item No.	PU
LA/RB- Left side (above)		Hinge cup: diecast;	298.705.92.5015	250
Right side (below)		Hinge arm: nickel-plated		



Description	Location	Material	Item No.	PU
RA/LB- Right side (above)		Hinge cup: diecast;	298.705.92.5115	250
Left side (below)		Hinge arm: nickel-plated		

**Note: product lead time approximately 12 weeks.**

### Pull



Description	Material	Item No.	PU
Pull	Diecast, nickel-plated fixing with double-sided adhesive pad	371.290.00.0015	250

**Note: product lead time approximately 12 weeks.**

### Hinge Dimensions

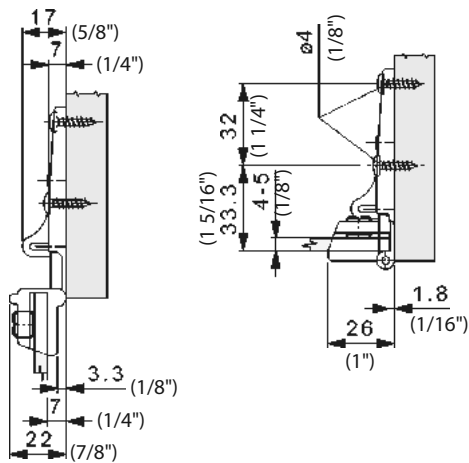

### Installation

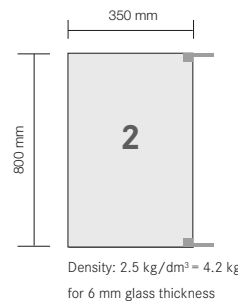

#### Hinge Installation

Stick the double-sided adhesive pad on the corner of the glass door. Peel off the foil. Place the glass door, the side with the pad facing outwards, into the mounted hinge. Tighten the fixing screw.

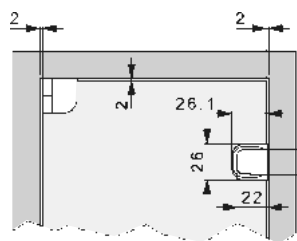

#### Pull Installation

Stick the double-sided adhesive pad onto the glass door. Peel off the foil. Place the glass door, the side with the pad facing outwards, into the pull. Tighten the fixing screw.

**IMPORTANT** To determine the correct application Grass strongly recommends a trial mounting for all hinges and base plates.

PU - Packaging unit

# Machinery

## GRASS PRO1 drilling and insertion machine for 45mm boring pattern

### GRASS PRO1

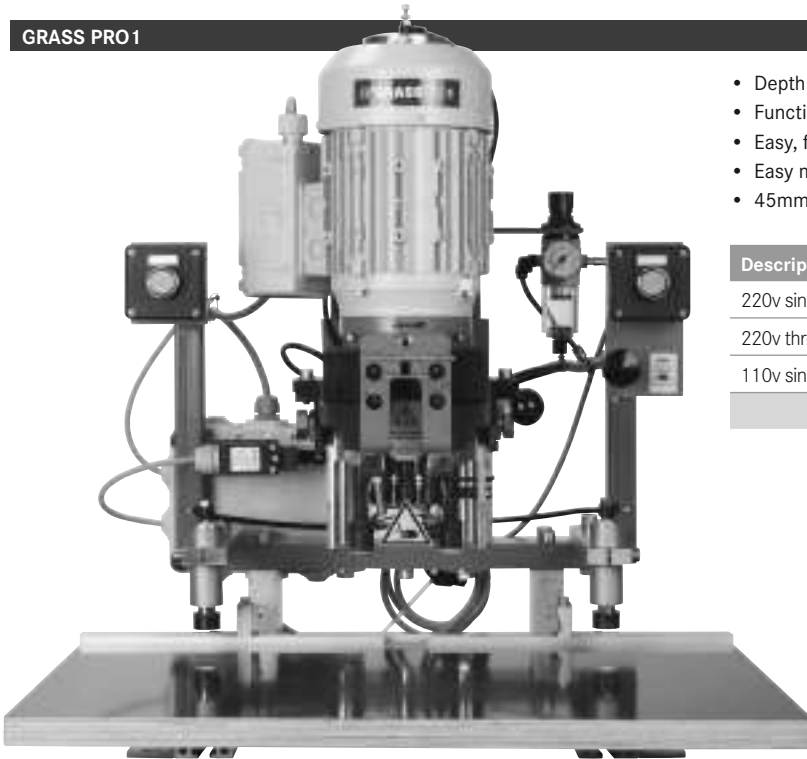

- Depth stop can be adjusted to material thickness
- Functional design
- Easy, fast and efficient operation
- Easy maintenance
- 45mm boring pattern

Description	Item No.	PU
220v single phase pneumatic	94559-01	1
220v three phase pneumatic	94560-01	1
110v single phase pneumatic	94561-01	1

### GRASS PRO1 Features



#### Adjustable hold-down devices

Adjustable hold-down devices are suitable for a wide range of material thicknesses.

Holds door firmly in place for drilling and insertion and features manual release.



#### Pneumatic controls

Two-hand start button controls for safe drilling and insertion functions.



#### Quick change chucks

Easy drill bit removal and insertion using quick change chucks.

PU - Packaging unit

# Machinery

## GRASS PRO1 accessories

### Drill Bits

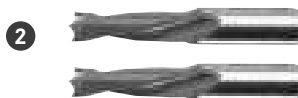

Description	Direction	Item No.	PU
1 35mm bit	RH	00077-01	1
2 8mm bit	LH	00160-01	1

American Bit Set for Hinge Drilling	Item No.	PU
1 x 35mm/RH, 2 x 8mm/LH	00213-01	1

### Fence Stops

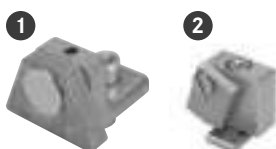

Description	Item No.	PU
1 Additional fence stop	949.200.21.0000	1
2 Universal fence stop	949.200.21.0100	1

### Insertion Dies

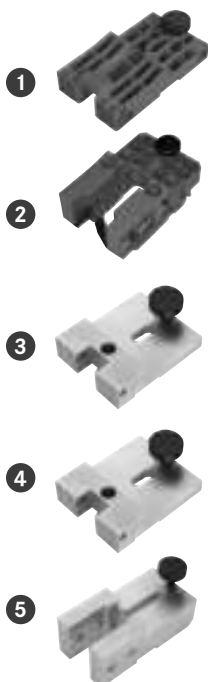

Description	Item No.	PU
1 Tiomos 110°/120°	<b>F146101310201</b>	1
2 Universal die for Tiomos 110°/120°/160°	<b>F146101308201</b>	1
3 TEC Die for all cup styles	92617	1
4 Nexis 110°/125°	04216-01	1
5 Nexis 170°	04218-01	1

### Extension Fence



Description	Item No.	PU
Extension fence 400mm to 1650mm	88612-01	1

PU - Packaging unit



GRASS America Inc.  
1202 NC Highway 66 South  
Kernersville, NC 27284

Phone: 1-800-334-3512  
Fax: 1-800-525-8406

Website: [www.grassusa.com](http://www.grassusa.com)  
E-mail: [info@grassusa.com](mailto:info@grassusa.com)

GRASS Canada Inc.  
10 Newgale Gate, Unit 7  
Toronto, ON M1X 1C5

Phone: 1-800-461-4975  
Fax: 1-416-335-5907

Internet: [www.grasscanada.com](http://www.grasscanada.com)  
E-Mail: [info@grasscanada.com](mailto:info@grasscanada.com)



[www.grassusa.com](http://www.grassusa.com)